

VERTICAL HI-RISE



Model Series 39VH & 39L

Features and Benefits

Engineered Comfort fan coil units are the only true commercial quality fan coil units available today. They are also the most versatile units on the market, because Engineered Comfort offers the largest list of options and features.

- Variable Air Volume Cooling and Heating with ECM / EPIC Fan Technology® eliminates noisy 3-Speed fans and provides superior room comfort (optional).
- ECM Motor will save 67% of the energy at typical set points (more at others), which gives the owner a major reduction in electrical usage (optional).
- Motor/blower combinations are mounted on special 16 ga. (1.61) angles and isolated from casing with rubber insulators.
- The units are designed for easy installation and, with modular construction, easy repair.
- Units are available with chilled / hot water coils and electric heat.
- All units are certified by AHRI and listed by ETL and display the AHRI and ETL symbols.
- Coil options allow for 3 to 5 row chilled water and 1 or 2 row hot water. 5 rows total in combination.
- The units are shipped completely assembled to reduce field labor cost.
- All units are fully inspected and run tested at the factory to eliminate potential problems at start up.
- Available with stand-alone electronic controls, Digital controls (BacNet compliant) or with factory mounted Digital controls supplied by others.
- Factory supplied controls are tested and calibrated at the factory.
- Custom needs that are job specific can be incorporated into the units
- Ultra-violet light option helps keep the coil clean and reduces re-circulation of microbes which reduces: Allergy Asthma, Upper respiratory ailments, Headaches, Sinus congestion and even Colds and Flu.
- Most models can be configured in a stand alone, master/slave or paired arrangement.



- Risers (2 and 4 pipe configurations) can be located on the back, left or right side of unit
- Commercial Grade Supply Grille(s) are available on the front, left or right side of unit
- Quarter turn latches for easy, quick panel removal and access
- Removable controls enclosure
- Powder coat painted finish resists scuffing and scratching
- Slide out blower for easy maintenance
- Nailor ECM/EPIC Fan Technology®, ECM Motor with variable air volume (optional)
- Stainless steel flex hoses with full port ball valves
- UV Light w/safety switch (optional)
- Factory mounted control valves and piping packages
- Filter rack
- Coils are AHRI 410 listed and labeled
- Commercial grade return grille
- 1" (25) Throwaway (default)
1" (25) MERV 8 pleated (optional)
- Insulated galvanized drain pan (Stainless steel available)

Not Shown:

- Fan access panel
- Electrical knockout
- Rubber condensate P-trap
- Adjustable shroud (optional)
- Condensate pump (optional)
- DDC controller (optional)
- Dust tight controls enclosure (optional)
- Electric heat (optional)
- Freeze thermostat (optional)
- Outside air damper (optional)
- Stainless steel coil casing (optional)
- Sub-base (optional)

Model Series 39VH & 39L

Standard Features

CONSTRUCTION:

- 20 ga. (1.00) G60 galvanized steel casing.
- 1/2" (13) thick, 2 lb/cu. ft. density fiberglass (tough guard) insulation with water repellent facing.
- Integral filter rack with 1" (25) throwaway filter.
- AHRI 440 certified and labeled.

FAN ASSEMBLIES:

- Forward curved, DWDI centrifuged type blowers.
- 3-Speed PSC motor with thermal overload protection.
- Quick disconnect motor connections.
- Easily removable slide out fan/motor deck for service.

COILS:

- Cooling – 3 or 4 row chilled water.
- Heating – 1 or 2 row hot water. Reheat position.
- 5 Rows total in combination.
- 1/2" (12.7) O.D. seamless copper tubes.
- 0.016" (0.406) tube wall thickness.
- 0.0045" (0.114) aluminum corrugated fins.
- Easily removable for service.
- Manual air vent(s).
- AHRI 410 certified and labeled.

DRAIN PANS:

- Single wall galvanized steel with fiber-free elastomeric external insulation.
- Positively sloped to drain connection.
- 7/8" (22.2) O.D. drain connection.
- Factory installed P-trap.

FRONT RETURN AIR PANEL:

- High performance louvered blade return air grille.
- Quarter-turn cam lock fasteners.
- Durable baked powder coat Appliance White paint finish.

SUPPLY AIR LOCATION:

- Front, left, right and back supply grille options.
- Top outlet (ducted for remote grilles).
- Aluminum double deflection grille(s).

ELECTRIC HEAT:

- ETL listed as an assembly.
- See separate page for construction details.

ELECTRICAL:

- ETL listed for safety compliance.
- Removable electrical enclosure with hinged access door for controls and electric heat. 120, 208, 240 or 277 Volts (60 Hz) power supply.

Options and Accessories

CONSTRUCTION:

- 1/2" (13) Steri-liner, 4 lb/cu. ft. density foil backed insulation.
- 1/2" (13) Fiber-free elastomeric closed cell foam insulation.
- 1" (25) MERV 8 pleated filter.
- Manual or motorized outside air damper.
- Custom built sub-base.
- Adjustable ceiling shroud on exposed units.

FAN ASSEMBLIES:

- Ultra-high efficiency ECM fan motor with fuse protection.
- Variable Air Volume control with ECM/EPIC Fan Technology®.

COILS:

- Automatic air vent(s).
- Stainless steel coil casings.
- Increased tube wall thickness 0.025" (0.635).

DRAIN PANS:

- Stainless steel construction with fiber-free elastomeric external insulation.

FRONT RETURN AIR PANEL:

- Full unit height with integral supply grille.
- Custom colors to suit architect.

SUPPLY AIR LOCATION:

- Double or triple outlets.
- Sight and sound baffles for double outlets where required.
- Opposed blade dampers.

ELECTRICAL:

- Fan relay packages.
- Toggle disconnect switch.
- Drain pan overflow float switch.
- Dust tight enclosure
- Sump pump.
- Ultraviolet lights.
- Main fusing.
- Quiet contactors.

CONTROLS:

- Digital VAV sequences.
- 3-Speed fan operation with LCD digital display or programmable thermostats.
- Unit or wall mounted thermostats.
- Automatic and manual changeover.

RISERS:

- 2 pipe configuration (cooling only or heat/cool changeover).
- 4 pipe configuration (cooling and heating).
- Type K, L or M copper with swaged connections.
- 3/4" to 3" (19 to 76) diameter.
- 1/2" and 3/4" (13 and 19) closed cell foam insulation.
- Riser extensions.
- Riser chase.
- Factory mounted or shipped in advance.

PIPING PACKAGES:

- Factory assembled and installed.
- Stainless steel flexible hoses with isolation ball valves and memory stop.
- 2-way or 3-way valves.
- 2 position or modulating valve actuators.
- Flow control devices.



Model Series 39VH • High Performance (88" High)

MODELS:

- 39VHZ** Chilled/Hot Water (2-pipe).
- 39VHZW** Chilled & Hot Water (4-pipe).
- 39VHZE** Chilled Water & Electric Heat (2-pipe).
- 39VHW** Hot Water (2-pipe).

TYPES:

- C** Concealed **E** Exposed **A/B** Paired
- M** Master **S** Slave

The 39VH Series Vertical Hi-rise Fan Coil Units are designed for quick installation, easy maintenance and a wide range of customer configurations. These units are designed to be "stacked" on each floor of a building, either alone or in pairs. This allows for a small, space-saving footprint with one set of risers for supply, return and drain lines. Flexible hoses allow for quick hook-up of water lines. The drain line connects with one ring clamp. Whether units are mounted behind drywall or are free standing in the room, the front panel and supply grille provide easy access to all internal parts. Filters can be replaced in seconds. Most major components are removed by loosening four to six screws or crown nuts. The 39VH family of products is designed to allow literally hundreds of different options involving heating and cooling capacities, air flow, fittings, power needs, fan coil configurations and riser layouts.

STANDARD FEATURES:

- Nine unit sizes ranging from 300 – 2100 CFM (142 – 991 l/s).
- Outer casing constructed of 20 gauge (1.00) galvanized steel.
- Energy efficient three speed PSC motors with thermal overload protection.
- Fully lined with 1/2" (13) x 2 lb. / cu. ft. density water repellent insulation.
- Removable controls enclosure with hinged access door.
- Easy access front panel and front supply grille for quick servicing.
- 1" (25) throwaway filter.
- AW Appliance White powder coat baked enamel finish on supply grille(s) and return air panel.

COIL OPTIONS:

2-pipe System:

- 1 Row HW only.
- 2 Row HW only.
- 3 Row C/HW.
- 4 Row C/HW.

4-pipe System:

- 3/1 CW/HW Rows.
- 3/2 CW/HW Rows.
- 4/1 CW/HW Rows.

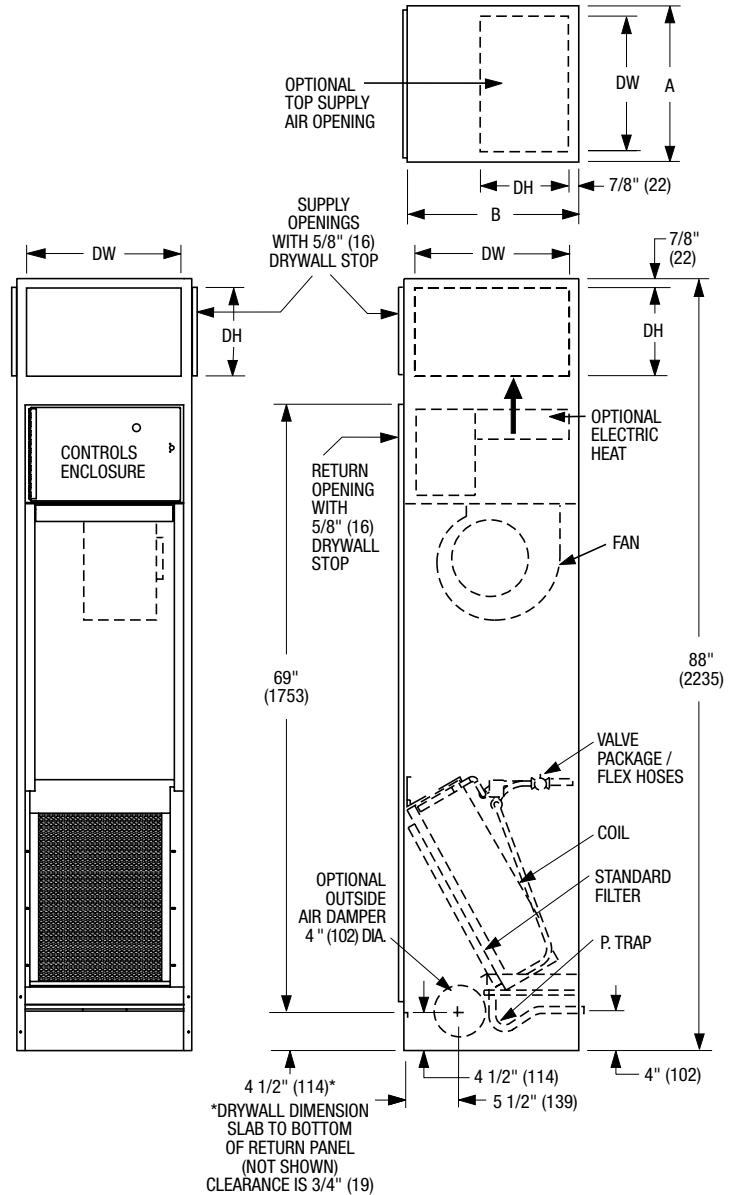

Dimensional Data

Unit Size	Footprint A x B	Supply Grille Nominal DW x DH	Filter Size W x H
3, 5, 6	18 x 18 (457 x 457)	16 x 10 (406 x 254)	13 1/8 x 16 3/4 (333 x 425)
8, 10	20 x 20 (508 x 508)	18 x 10 (457 x 254)	15 1/2 x 24 (394 x 610)
12, 15	24 x 24 (610 x 610)	22 x 10 (559 x 254)	18 1/2 x 29 (470 x 737)
19, 21	30 x 24 (762 x 610)	28 x 10 (711 x 254)	24 1/2 x 29 (622 x 737)

3-SPEED ECM / EPIC ECM MOTOR OPTION:

- 3-Speed ECM Motor: Nine unit sizes ranging from 300 – 2100 CFM (142 – 991 l/s).
- EPIC ECM Motor: Four unit sizes (6, 10, 15, 19) ranging from 600 – 1900 CFM (283 – 897 l/s). Wider turndown ratio.
- Significant energy savings.
- Variable Air Volume capability.

Model Series 39L • Low Profile (80" high)

MODELS:

- 39LZ** Chilled/Hot Water (2-pipe).
- 39LZW** Chilled & Hot Water (4-pipe).
- 39LZE** Chilled Water & Electric Heat (2-pipe).
- 39LW** Hot Water (2-pipe).

TYPES:

C Concealed **M** Master **S** Slave

The 39L Series Low Profile Vertical Hi-Rise Fan Coil Units are 8" (203) shorter than the standard model and are designed for use in buildings with a smaller than normal floor to floor height (e.g. 8 ft.). The reduced height of the unit enables better access to the rear risers for brazing. Other than the reduced height, the 39L Series shares all of the features and benefits of the 39VH Series described on the previous page.

STANDARD FEATURES:

- Nine unit sizes ranging from 300 – 2100 CFM (142 – 991 l/s).
- Outer casing constructed of 20 gauge (1.0) galvanized steel.
- Energy efficient PSC motor with thermal overload protection.
- Fully lined with 1/2" (13) x 2 lb. / cu. ft. density water repellent insulation.
- Removable controls enclosure with hinged access door.
- Easy access front panel and front supply grille for quick servicing.
- 1" (25) throwaway filter.
- AW Appliance White powder coat baked enamel finish on supply grille(s) and return air panel.

COIL OPTIONS:

2-pipe System:

- 1 Row HW only.
- 2 Row HW only.
- 3 Row C/HW.
- 4 Row CW.

4-pipe System:

- 3/1 CW/HW Rows.
- 3/2 CW/HW Rows.
- 4/1 CW/HW Rows.

3-SPEED ECM / EPIC ECM MOTOR OPTION:

- 3-Speed ECM Motor: Nine unit sizes ranging from 300 – 2100 CFM (142 – 991 l/s).
- EPIC ECM Motor: Four unit sizes (6, 10, 15, 19) ranging from 600 – 1900 CFM (283 – 897 l/s).
- Significant energy savings.
- Variable Air Volume capability.

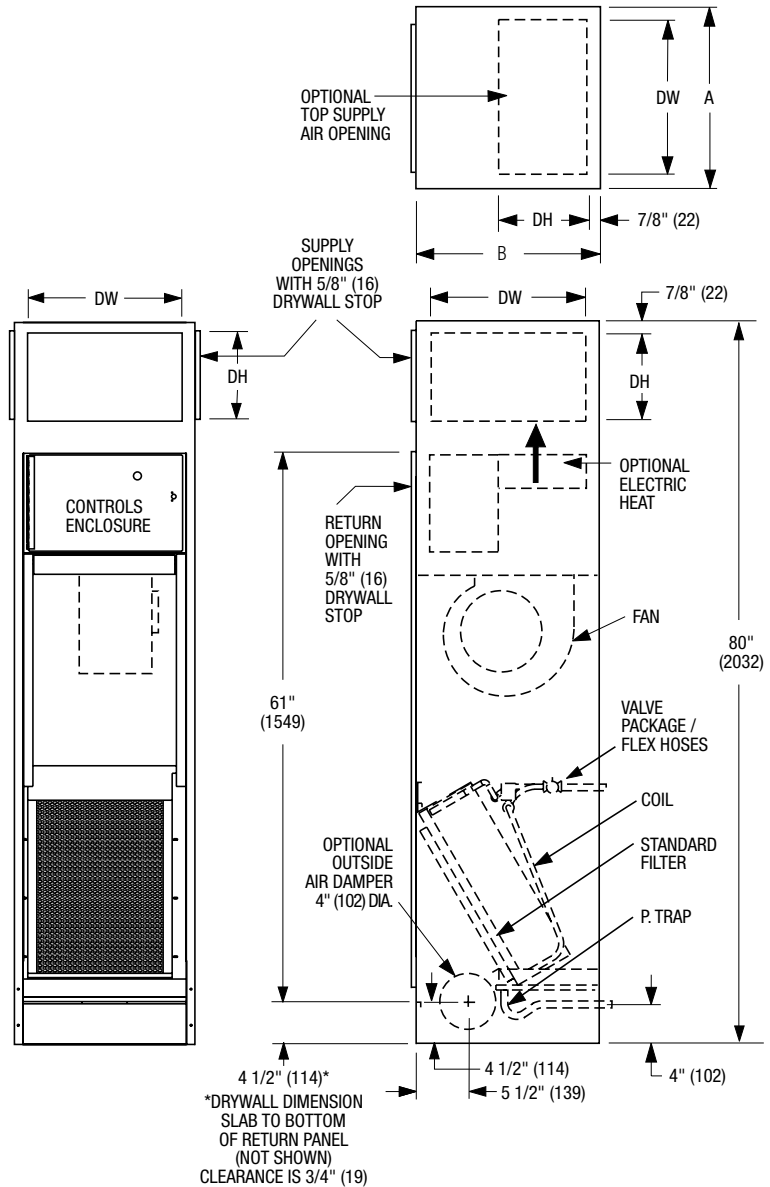

Dimensional Data

Unit Size	Footprint A x B	Supply Grille Nominal DW x DH	Filter Size W x H
3, 5, 6	18 x 18 (457 x 457)	16 x 10 (406 x 254)	13 1/8 x 16 3/4 (333 x 425)
8, 10	20 x 20 (508 x 508)	18 x 10 (457 x 254)	15 1/2 x 24 (394 x 610)
12, 15	24 x 24 (610 x 610)	22 x 10 (559 x 254)	18 1/2 x 29 (470 x 737)
19, 21	30 x 24 (762 x 610)	28 x 10 (711 x 254)	24 1/2 x 29 (622 x 737)

Dimensions are in inches (mm).

Model Series 39MU • Low Profile • Updraft Design

MODELS:

- 39MUZ** Chilled Water.
- 39MUZW** Chilled and Hot Water.
- 39MUZE** Chilled Water and Electric Heat.
- 39MUW** Hot Water (2-pipe).

The 39MU Low Boy Vertical Fan Coil Unit product line is a compact design for concealed stand-alone applications (such as in a closet). The standard Updraft model features bottom return air entry and is raised off the floor by mounting on a platform. When the optional front panel return grille is selected, the unit may be floor mounted or mounted in a pipe chase. The top discharge is designed for ducted connection to a remote grille(s).

The units are designed with a small space-saving footprint for quick installation, easy maintenance and with a wide range of options and configurations. A removable front panel provides easy access to all internal components. Flexible hoses allow for quick hook-up of water lines. The drain line connects with one ring clamp.

STANDARD FEATURES:

- Nine unit sizes ranging from 300 – 2100 CFM (142 – 991 l/s).
- Outer case constructed of 20 gauge (1.0) galvanized steel.
- Energy efficient PSC motor with thermal overload protection.
- Fully lined with 1/2" (13) thick, 2 lb/cu. ft. density water repellent insulation.
- Controls enclosure with door interlock disconnect for safety.
- Easy access front panel for quick servicing.
- 1" (25) throwaway filter.
- Galvanized steel insulated drain pan.
- Factory installed P-Trap.

COIL OPTIONS:

- 2-pipe System:**
- 1 Row HW only.
 - 2 Row HW only.
 - 3 Row C/HW.
 - 4 Row C/HW.
- 4-pipe System:**
- 3/1 CW/HW Rows.
 - 3/2 CW/HW Rows.
 - 4/1 CW/HW Rows.

3-SPEED ECM/EPIC ECM MOTOR OPTION:

- 3-Speed ECM Motor: Nine unit sizes ranging from 300 – 2100 CFM (142 – 991 l/s).
- EPIC ECM Motor: Four unit sizes (6, 10, 15, 19) ranging from 600 – 1900 CFM (283 – 897 l/s). Wider turndown ratio.
- Significant energy savings.
- Variable Air Volume capability.

Dimensional Data

Unit Size	Footprint A x B	Height H	Discharge Nominal DW x DH	Return Opening RW x RH	Opt. Return Grille Nominal IW x IH	Filter Size W x H
3, 5, 6	18 x 18 (457 x 457)	55 (1397)	16 x 10 (406 x 254)	15 x 8 (381 x 203)	16 x 15 (406 x 381)	13 1/8 x 16 3/4 (333 x 425)
8, 10	20 x 20 (508 x 508)	55 (1397)	18 x 10 (457 x 254)	17 x 9 (432 x 229)	18 x 21 (457 x 533)	15 1/2 x 24 (394 x 610)
12, 15	24 x 24 (610 x 610)	60 (1524)	22 x 10 (559 x 254)	21 x 12 (533 x 305)	22 x 26 (559 x 660)	18 1/2 x 29 (470 x 737)
19, 21	30 x 24 (762 x 610)	60 (1524)	28 x 10 (711 x 254)	27 x 12 (686 x 305)	28 x 26 (711 x 660)	24 1/2 x 29 (622 x 737)

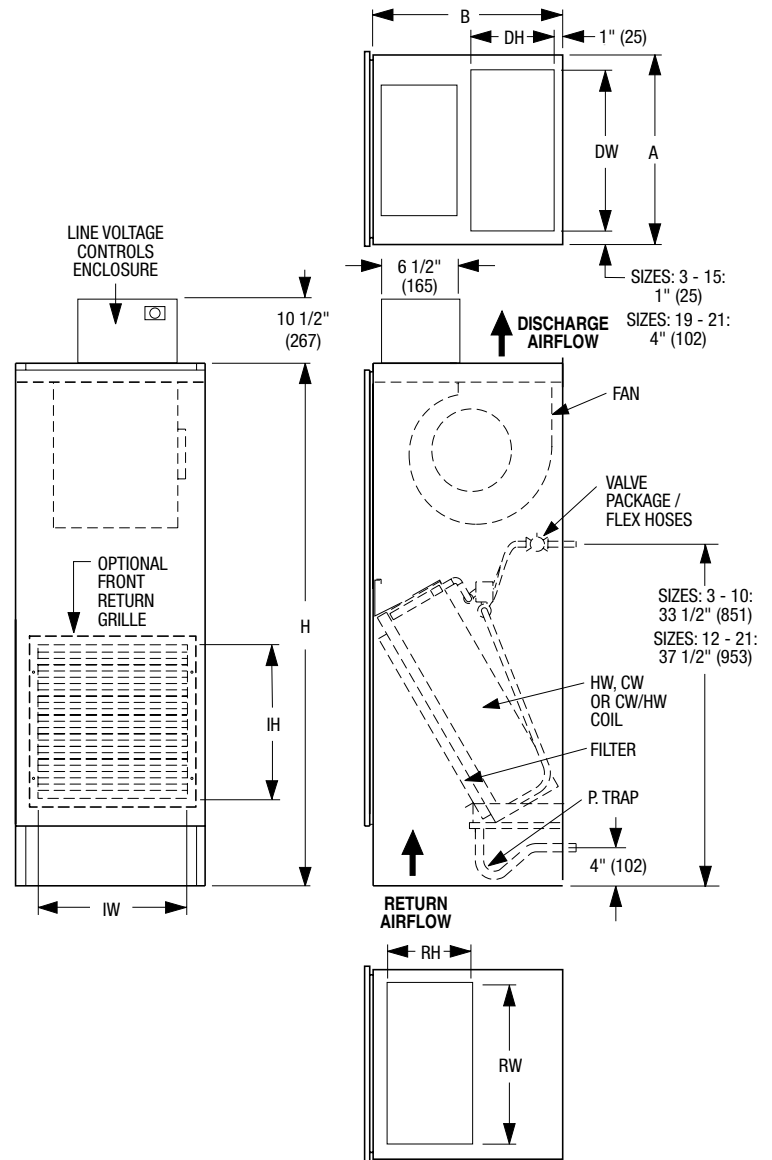

Model Series 39MU • Low Profile • Updraft Design

POWER SUPPLY VOLTAGE:

(Units without electric heat)

Single Phase (60 Hz):

- 120, 208, 240 and 277V.

ECM MOTOR:

- Ultra-high efficiency ECM fan motor with fuse protection.
- Variable Air Volume control with ECM/EPIC fan technology®.

OTHER OPTIONS:

- 1" (25) MERV 8 pleated disposable filter.
- Remote mounted thermostat.
- Custom build sub-base.

ELECTRIC HEAT SECTION:

Power Supply Voltage:

Single Phase, 60Hz:

- 120V • 208V • 240V • 277V

NOTE:

Incompatible heater/motor voltage selections require either a dual point power connection or a step-down transformer (consult Nailor).

STANDARD FEATURES:

- Heater is installed on unit discharge.
- Controls enclosure incorporates a hinged door and is recessed inside the heater unit. The enclosure is top mounted on updraft unit.
- Class A 80/20 Ni/Cr wire.
- Insulated coil element wrapper.
- Automatic reset high limit cut-outs (one per element).
- Single point electrical connection for entire fan coil unit.
- Fan interlock relay.
- Fan coil unit with electric heat is ETL Listed as an assembly.
- Door interlock disconnect switch.

OPTIONS:

- Dust tight construction.
- Quiet contactors.
- Mercury contactors.
- Power circuit fusing.
- Toggle disconnect switch.
- Manual reset secondary thermal cut-out.
- Airflow safety switch.

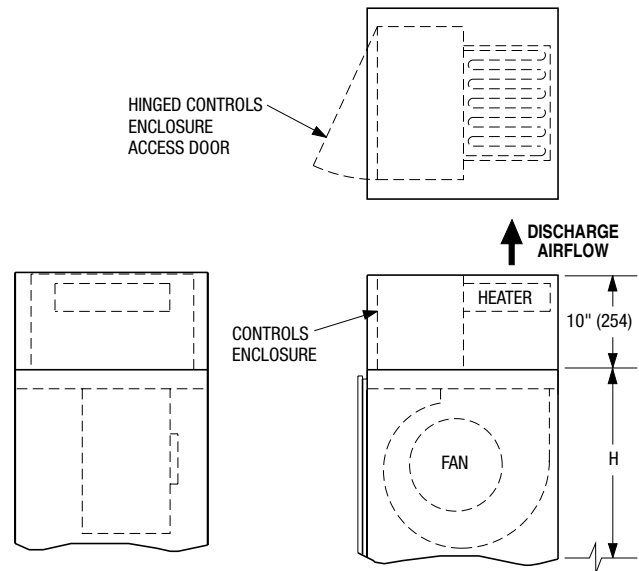

39MU UPDRAFT HEATER SECTION



Model Series 39VH & 39L • Electric Heating Coils • Construction Features, Selection and Capacities

Engineered Comfort Electric Coils are tested with the fan coil in accordance with UL Standard 1995 and meet all requirements of the National Electric Code and CSA. Units are listed and labeled by the ETL Testing Laboratory as an assembly. All controls are enclosed in a NEMA 1 electrical enclosure for easy access.

All wiring for the motor and heater terminates in the enclosure for single point electrical connection in the field. Each unit is supplied with a wiring diagram.

Note: NEC requires a means to disconnect the heater power supply within sight of or on the fan coil unit.

Power Supply Voltage:

- Single Phase, 60Hz:
- 120V • 208V • 240V • 277V

STANDARD FEATURES:

- Controls enclosure incorporates a hinged door and is recessed inside the unit. To access the controls enclosure remove the front panel.
- Automatic reset high limit thermal cut-outs.
- Magnetic contactors per stage on fan coils with DDC or electronic controls.
- Class A 80/20 Ni/Cr wire.
- Control voltage transformer (Class 2) for DDC and electronic fan coils.

Optional Accessories:

- Toggle disconnect switch
- Main Switch
- Door interlocking disconnect switch
- Quiet contactors
- Mercury contactors
- Power circuit fusing
- Dust tight control enclosure
- Manual reset secondary high limit
- Airflow safety switch



Recommended Selection:

The table below is a quick reference guide, to illustrate the relationship between electrical power supply, heater capacity in kilowatts and fan coil unit size that are available.

- Fan coils are available with 1 stage of heat as standard (2 stages of heat are optional with digital controls). A minimum of 0.5 kW per stage is required.
- Voltage and kilowatt ratings are sized so as not to exceed 48 amps, in order to avoid the NEC code requirement for circuit fusing.
- A minimum airflow of 70 CFM (33 l/s) per kW is required for any given fan coil in order to avoid possible nuisance tripping of the thermal cut-outs.
- Discharge air temperature should not exceed 115°F (46°C).

Useful Formulae:

$$kW = \frac{CFM \times \Delta T}{3160}$$

$$\Delta T = \frac{kW \times 3160}{CFM}$$

$$1ph.Amps = \frac{kW \times 1000}{volts}$$



Intertek

Tested and approved to the following standards:

UL1995, 4th. ed.
CSA C22.2
No. 236-11.

Unit Size	Max.		Electric Heat Maximum Kilowatts			
	CFM	l/s	120V	208V	240V	277V
3	375	177	4	5	5	6.5
5	575	271	4	5	5	6.5
6	730	344	4	5	5	6.5
8	940	444	4	9	9	11.5
10	1100	519	4	9	9	11.5
12	1300	613	4	9	9	11.5
15	1700	802	4	9	9	11.5
19	1950	920	4	9	9	11.5
21	2200	1038	3.5	9	9	11.5

Electric Heating Coils • Application Guidelines

Discharge Air Temperature

When considering the capacity and airflow for the heater, discharge air temperature can be an important factor. Rooms use different types of diffusers, and they are intended to perform different functions. Slots that blend the air at the glass and set up air curtains within the room, must be able to blow the air very low in the room. Hot air will be too buoyant to be effective in this case. Discharge air temperatures for this application should be in the 85 – 90°F (29 – 32°C) maximum range.

Diffusers in the center of the room blend their discharge air as it crosses the ceiling. Discharge air temperatures in this application can be as high as 105°F (41°C) and still be effective. However, if the return air grilles are in the discharge air pattern, the warm air will be returned to the plenum before it heats the room. Again, the air temperature needs to be blended down to an acceptable temperature that can be forced down into the occupied space by the time the air gets to the walls. Discharging warm air into the room at temperatures above 105°F (41°C) usually will set up stratification layers and will not keep the occupants warm if there is a ceiling return because only the top 12" – 24" (300 – 600 mm) of the room will be heated.

The maximum approved discharge air temperature for any Engineered Comfort Fan Coil Units with supplemental heat is 120°F (49°C). No heater should be applied to exceed this temperature.

Electric Heater Selection

To properly select an electric heater, three things must be determined: the heat requirement for the room, the entering air temperature and the desired discharge air temperature. The heat requirement for the room is the sum of the heat loss calculation and the amount of heat required to raise the entering air temperature to the desired room temperature. Usually, the second item is small compared to the first for fan coil units in a return air plenum. MBH can be converted to kW by using the chart or by calculation. There are 3413 Btu's in 1 kW. If using the chart, find the MBH on the left scale, then move horizontally to the right and read kW.

Next, the desired discharge air temperature should be ascertained. This will depend on the type of diffusers that are in the room.

The desired heating airflow for the room can then be calculated using the following equation:

$$CFM = \frac{kW \times 3160}{\Delta T \text{ (Discharge air temp - Inlet air temp.) } ^\circ F}$$

Assuming 70°F (21°C) supply air temperature to the heater, the room airflow can be selected directly from the chart. Start at the left at the design kW. Move horizontally to the desired discharge air temperature. Then, move vertically down to the CFM at the bottom of the chart.

The kW can be selected directly from the chart. Start at the bottom with the design CFM into the room. Move vertically up to the line that represents the desired discharge air temperature. Then, move left to the kW.

The discharge air temperature can also be selected directly from the chart. Start at the bottom with the design CFM into the room. Move to the left side of the chart and find the design kW. Move horizontally and vertically into the chart until the lines intersect. The intersection will be the desired discharge air temperature. Interpolation between the curves is linear.

Heater Selection Chart

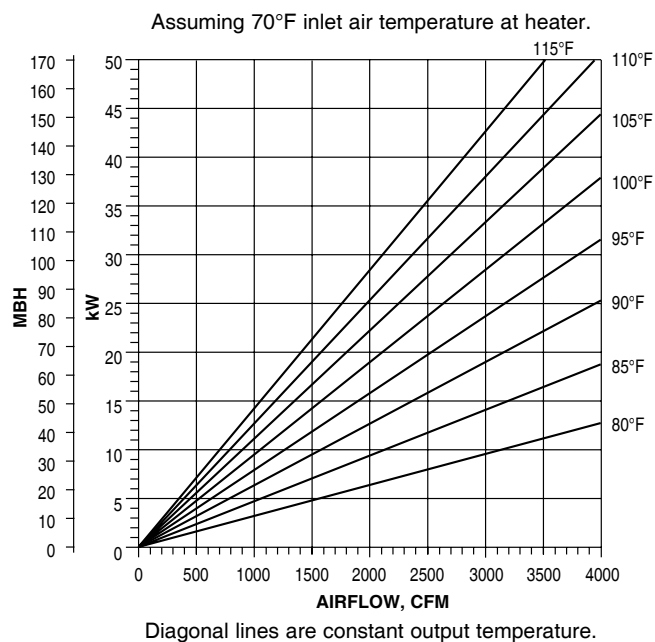

Model Series 39VH • 2 or 4-pipe System with Full Face Cover

- C Front Panel
- D Supply Grille
- E Return Air Grille
- F Alternate Side Grille Location
- G Fan Assembly
- H CW/HW Coil
- J Drain Pan
- K Filter
- K-1 Filter Rack
- L Fan Access Panel
- M Controls Enclosure
- M-1 Electric Heat (Opt.)
- N Risers (Opt.)
- P Electrical Knock-out
- R Control Valve
- S Flex Hose with Shut-off Valve
- T P-Trap
- U Quarter Turn Latches
- V Riser Chase (Opt.)
- W Sub-Base (Opt.)
- X Adjustable Ceiling Shroud for exposed units (Opt.)

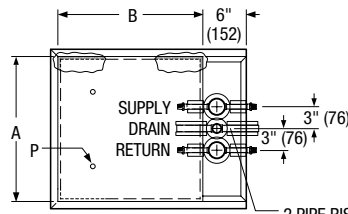

2 PIPE SYSTEM
TOP VIEW WITH SHROUD

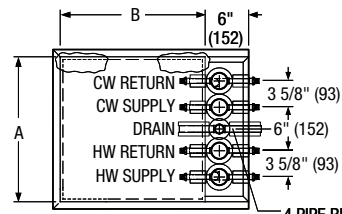

4 PIPE SYSTEM
TOP VIEW WITH SHROUD

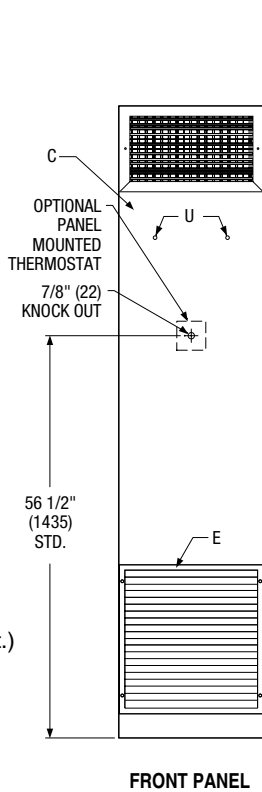

FRONT PANEL

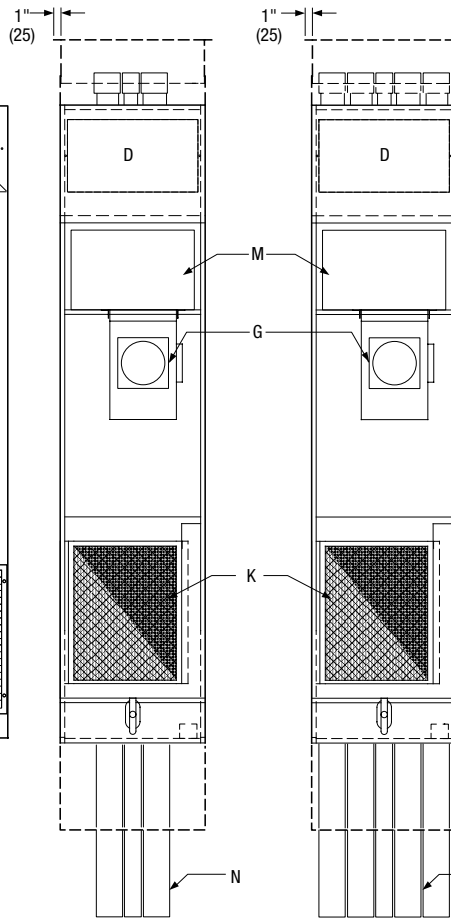

2 PIPE SYSTEM
FRONT VIEW

4 PIPE SYSTEM
FRONT VIEW

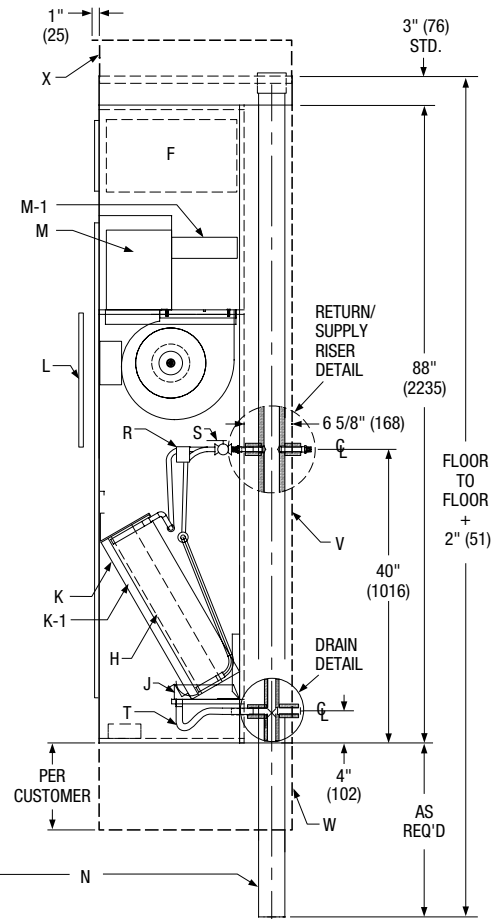

SIDE VIEW

Model Sizes

Unit Size	Nominal Airflow Range (CFM)	Nominal Cooling Capacity (MBH)	Footprint A x B inches (mm)
3, 5, 6	300, 500, 600	15, 18, 22	18 x 18 (457 x 457)
8, 10	800, 1000	30, 34	20 x 20 (508 x 508)
12, 15	1200, 1500	42, 46	24 x 24 (610 x 610)
19, 21	1900, 2100	60, 65	30 x 24 (762 x 610)

NOTES:

All units are designed to accept both two- and four-pipe riser configurations. Risers can be located on the right side, left side or back of the unit. Supply grilles can be located on the front right side or left side of the unit. Return grilles are located on the front of the unit.

Dimensions are in inches (mm).

Model Series 39VH • Piggyback Assembly

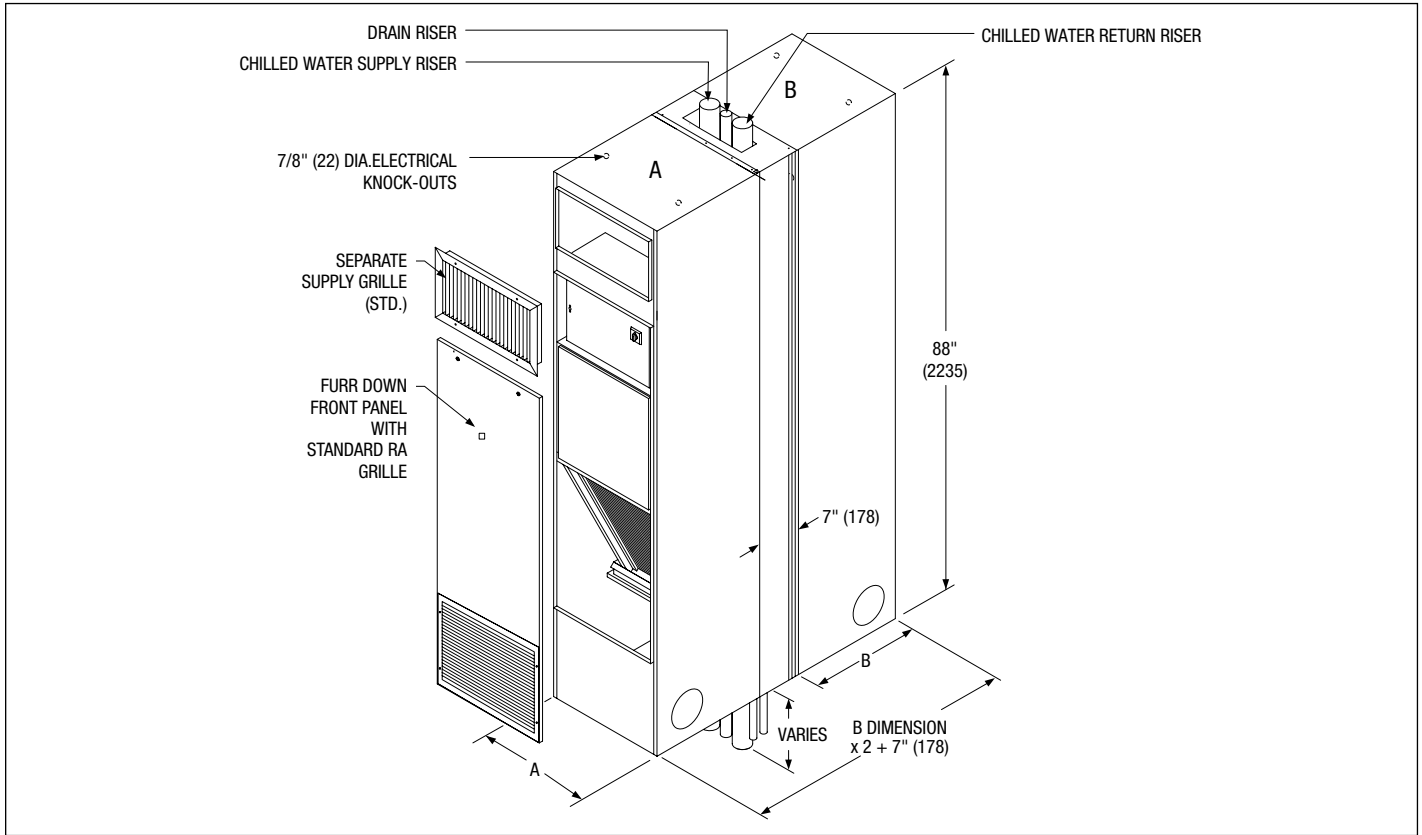

A
VERTICAL HI-RISE/STACK FAN COIL UNITS

Type A/B Paired Unit • Side by Side Assembly

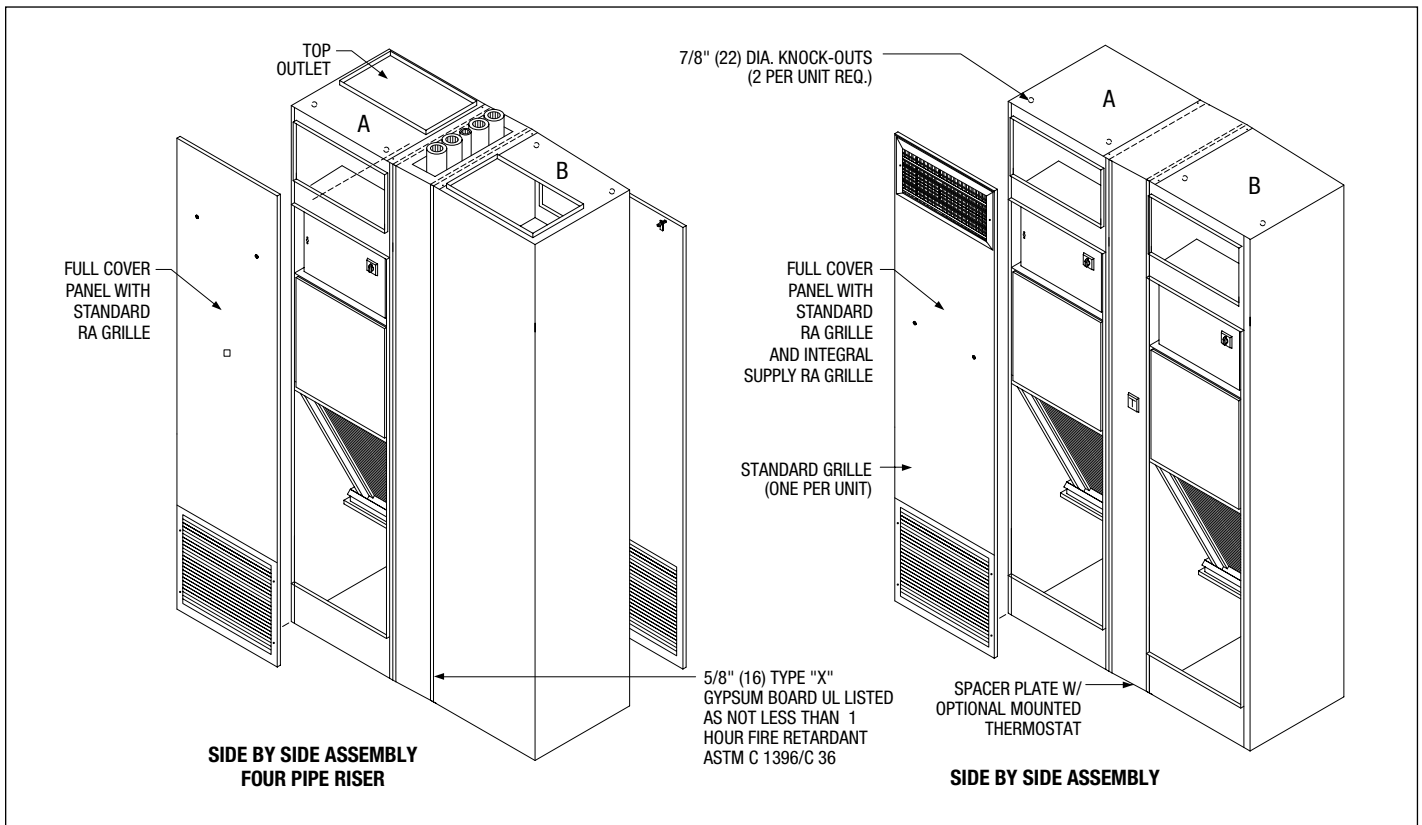

Model Series 39VH & 39L • Unit Configurations for Riser Location & Discharge Grille Arrangement

SINGLE SIDE SUPPLY

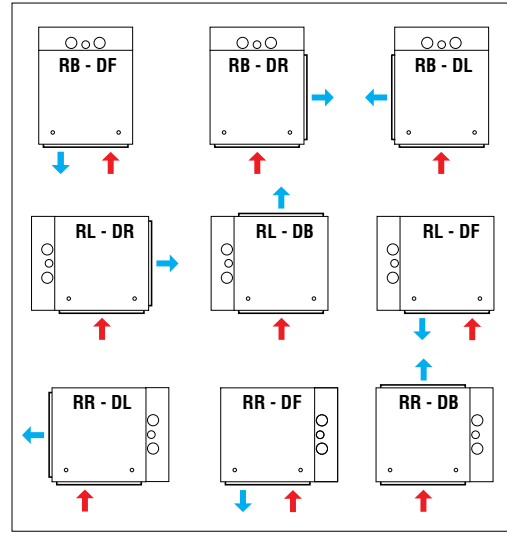

DOUBLE SIDE SUPPLY

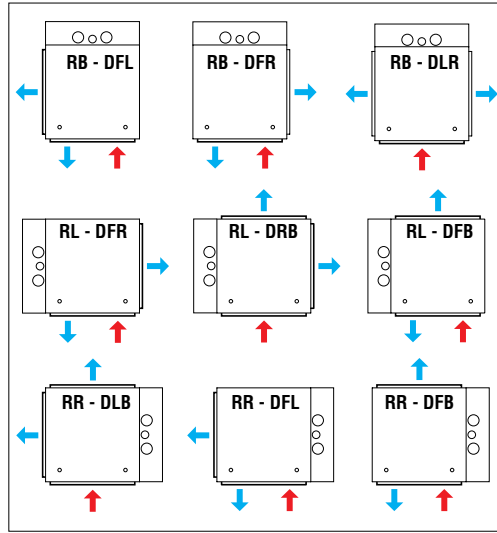

UNIT DESIGNATIONS

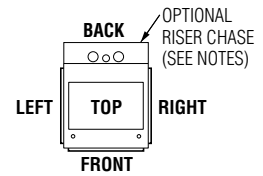

EXAMPLE: RB-DFXXX-VR

RISER LOCATION:

RB = BACK
RR = RIGHT
RL = LEFT

DISCHARGE GRILLE LOCATION 1:

DF = FRONT
DT = TOP
DL = LEFT
DR = RIGHT

DISCHARGE GRILLE LOCATION 2, 3 & 4:

L = LEFT
B = BACK
R = RIGHT
T = TOP

OUTSIDE AIR LOCATION:

VL = LEFT
VR = RIGHT

← SUPPLY AIRFLOW

→ RETURN AIRFLOW

NOTES:

- Return air panel and unit access are always on front of unit.
- A sight and sound baffle is provided on double side supply units with a directly opposite grille location. Not available with triple supply or top outlets.
- Opposed blade damper on one supply grille for units with double supply and two grilles for triple supply outlets.
- Last optional character refers to ventilation outside air location. Options are left or right side only and must be opposite to any left or right riser.
- Type C Stand-alone units shown with optional riser chase. Riser chase not available on Type M Master units. Type A units must be mated to Type B units. For Type B and S units, first character references connection location only (risers are on Type A or M unit respectively).
- Exposed models are available as standard with RB Riser Back location only.

TOP AND SINGLE SIDE SUPPLY

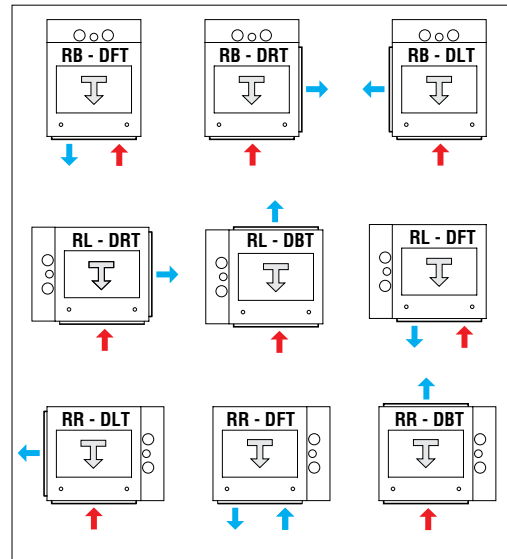

TOP AND DOUBLE SIDE SUPPLY

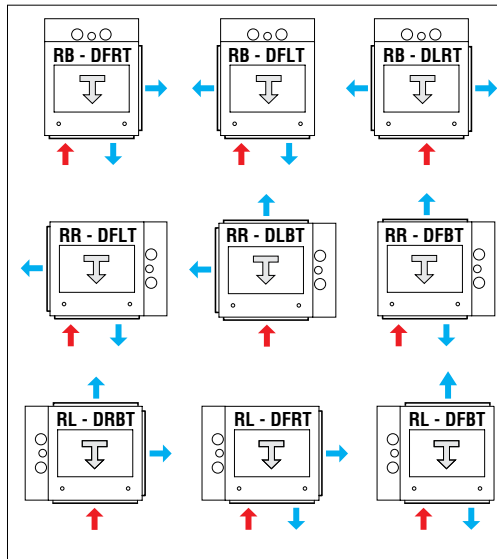

TOP ONLY SUPPLY

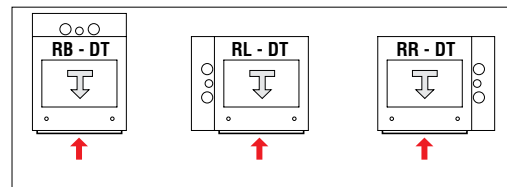

TOP AND TRIPLE SIDE SUPPLY

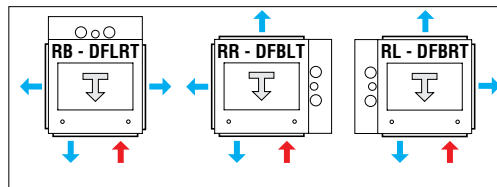

TRIPLE SIDE SUPPLY

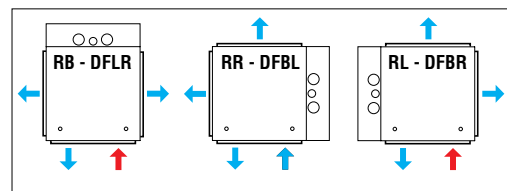

Model Series 39VH & 39L

Typical Stand-alone and Paired Unit Configurations

TYPE C - CONCEALED (STAND-ALONE):

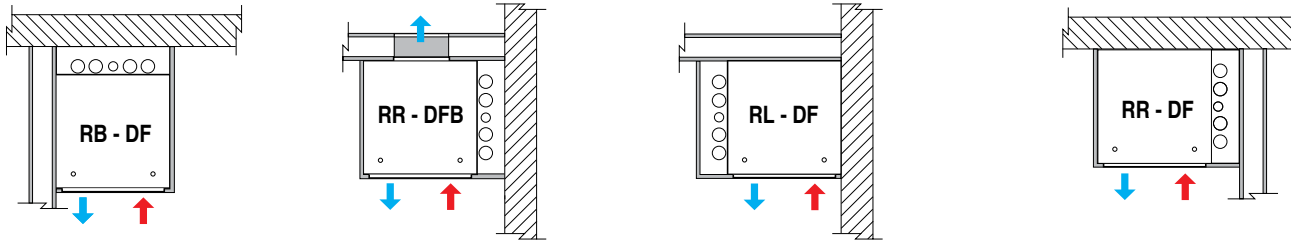

TYPE A/B - PAIRED:

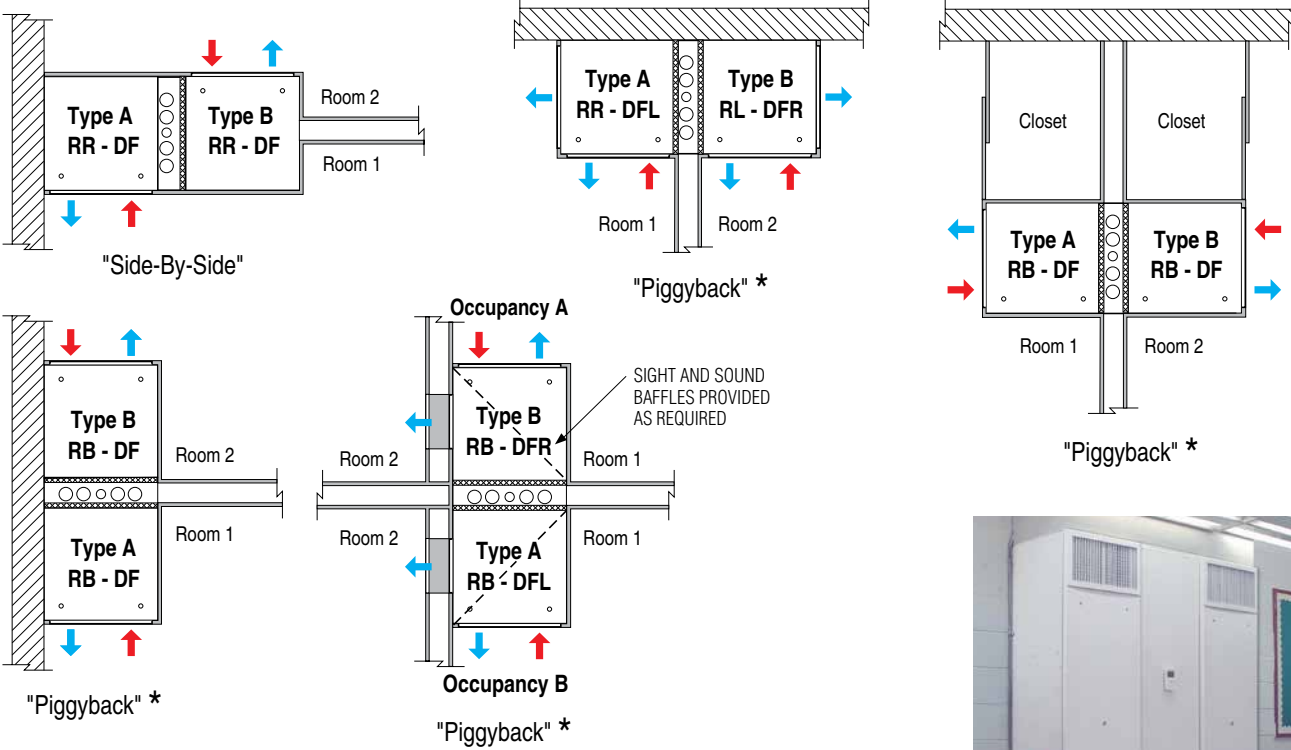

TYPE E - EXPOSED:

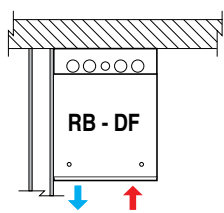

TYPE M/S - MASTER / REMOTE SLAVE:

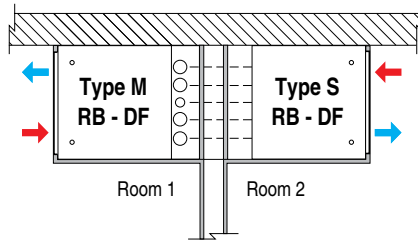

Custom side-by-side exposed installation

LEGEND:

- Exterior Wall
- Field Drywall (sheetrock)
- Interior Wall Partition or Separation
- Eng. Comfort "Type X" Gypsum wallboard
- Field installed piping
- Supply Air
- Return Air
- * Available in one-hour, UL fire-rated construction

- A** Master Unit (with risers)
- B** Slave Unit (with riser connection)

NOTES:

1. Above are just a few of the many arrangement possibilities.
2. For other combinations, see proceeding page and ensure compatibility.
3. Non-fire rated Paired units are standard (single wallboard) UL 1 Hour Label Fire-rated is an option (double "Type X" wallboard).

Model Series 39VH • Standard Front Return Air Panel for Type C Concealed Units Separate Supply Grille

A

VERTICAL HI-RISE/STACK FAN COIL UNITS

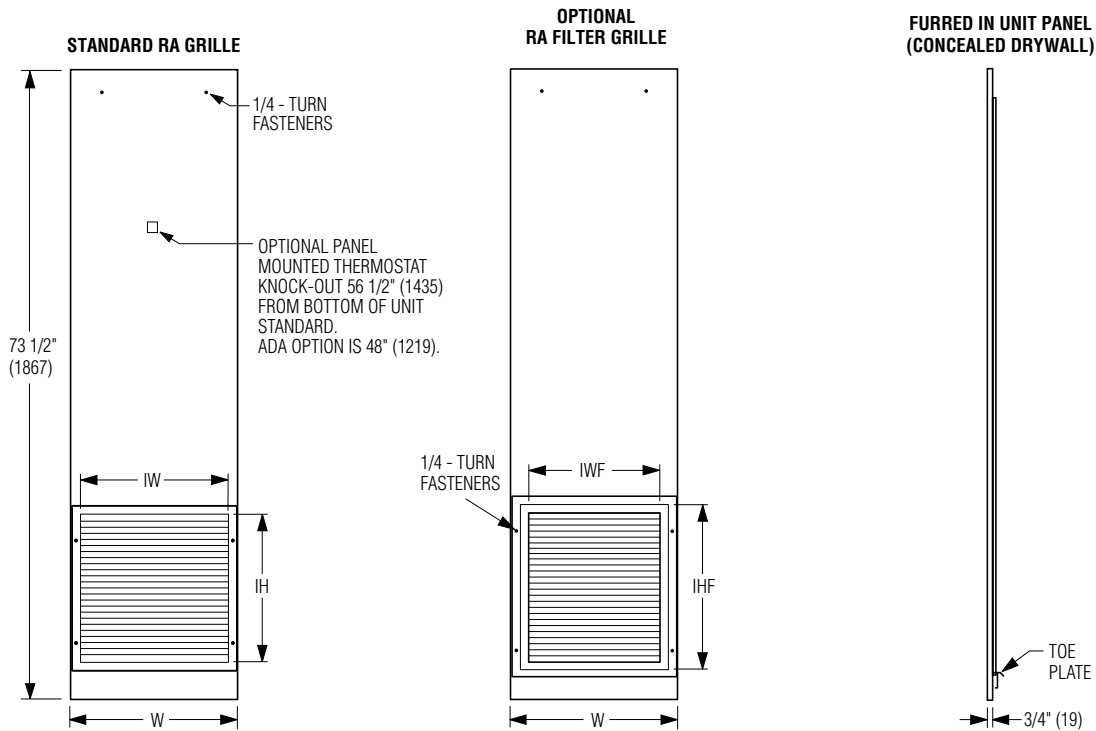

Optional Front Return Air Panels for Type C Concealed Units Extended Cover (with integral front supply grille where specified)

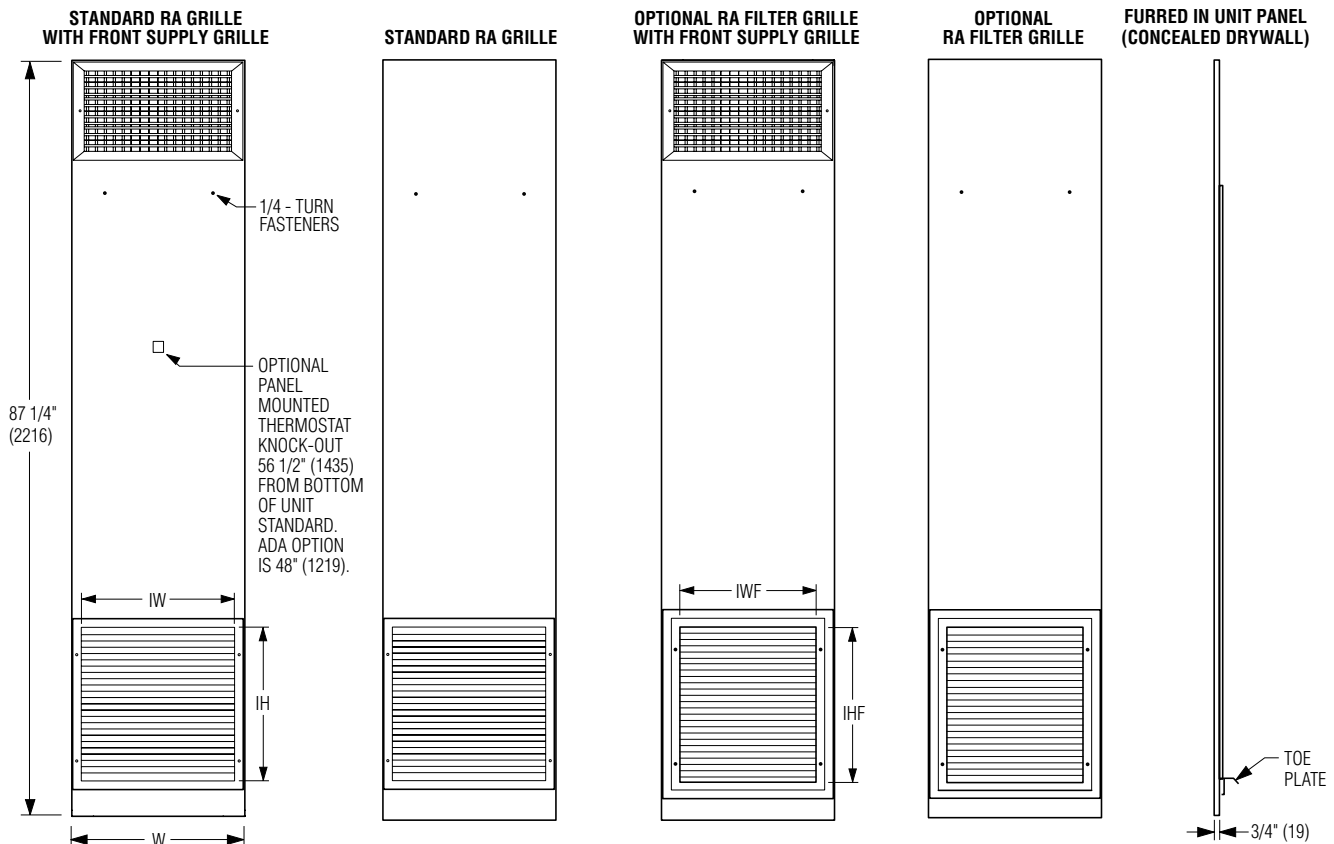

Model Series 39VH • Standard Front Return Air Panels for Type C Concealed Units • Extended Full Length Cover (with integral front supply grille where specified)

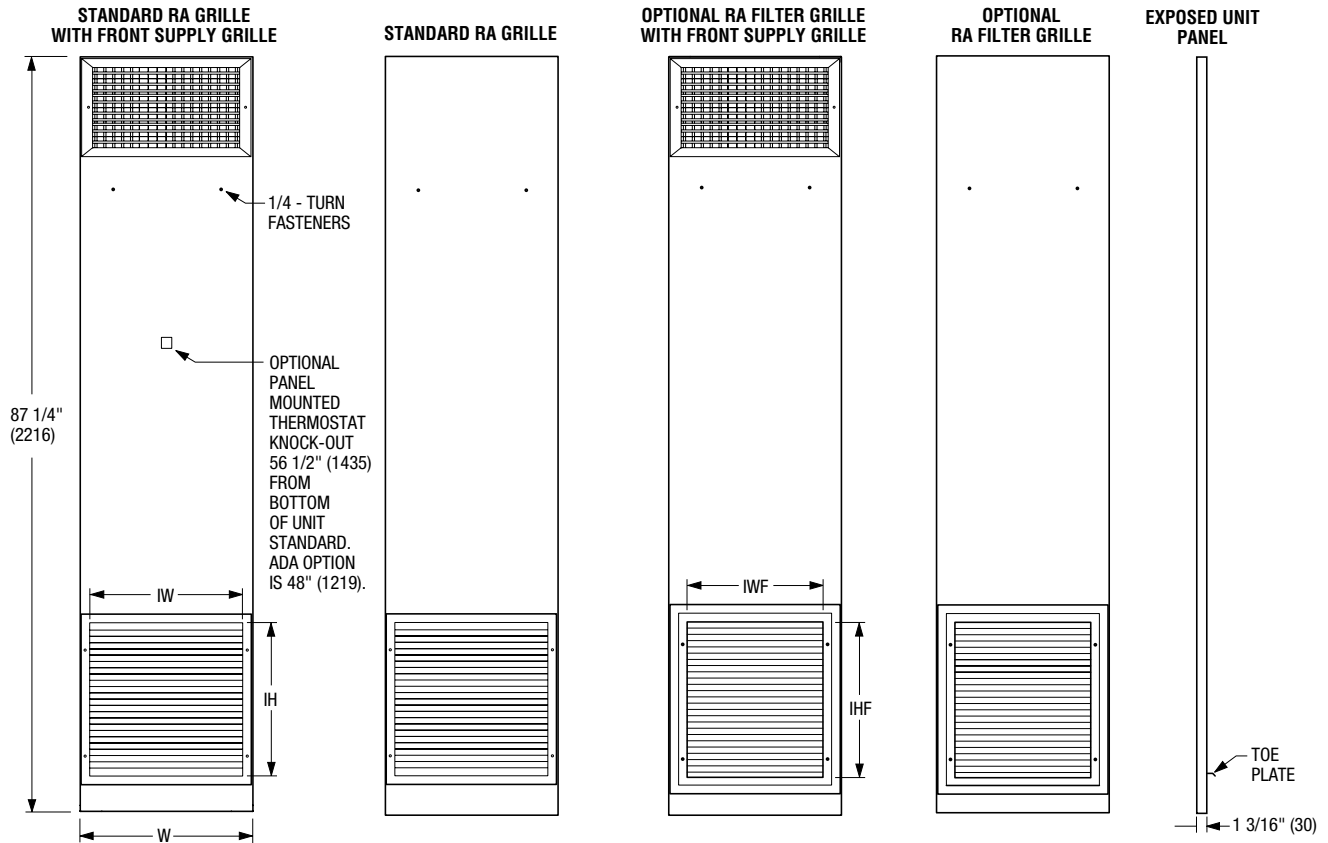

Dimensions:

Unit Size	W	Standard Return Air Grille IW x IH	Optional Return Air Filter Grille IWF x IHF
3, 5, 6	18 (457)	16 x 15 (406 x 381)	14 x 15 (356 x 381)
8, 10	20 (508)	18 x 21 (457 x 533)	16 x 21 (406 x 533)
12, 15	24 (610)	22 x 26 (559 x 660)	20 x 26 (508 x 660)
19, 21	30 (762)	28 x 26 (711 x 660)	26 x 26 (660 x 660)

Optional Aluminum Filter Return Grille:

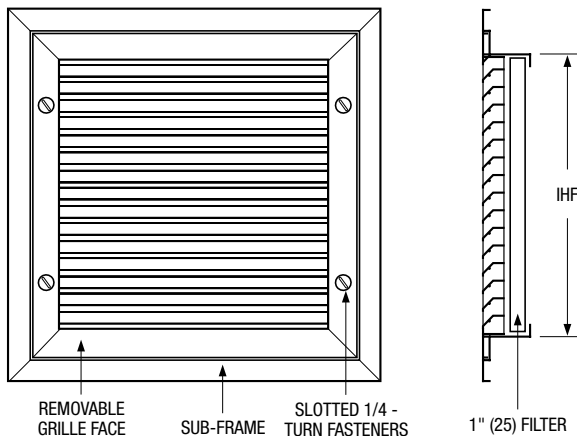

NOTES:

1. All front panels feature a high free area louvered return grille.
2. A removable face filter return grille is available. This option eliminates having to remove the front panel for easier filter replacement.
3. The standard reduced height front panels are designed for (furred-in) unit installation concealed by drywall [1/2" to 5/8" (13 to 16)] only.
4. Optional full cover front panels with integral grille are also available for concealed drywall installation.
5. Hi-Rise fan coil units designed for exposed installation feature a full length front panel with integral front supply grille where specified. These one piece panels mount flush and completely cover the front of the unit. The entire fan coil unit on the non-riser sides is also painted to match. An optional ceiling shroud extension for the fan coil unit is also available.
6. Model Series 39L panels are 8" (203) shorter.
7. Thermostat mounting option: A 7/8" (22.2) knock-out is provided on the return panel where this option is specified. Where the mounting location is to be in accordance with the Americans with Disabilities Act (ADA), the thermostat mounting height is lower than standard; 48" (1219) above the floor.
8. Standard finish is a durable baked enamel powder coat, AW Appliance White. Custom colors are available.

Model Series 39VH & 39L

Double Deflection Adjustable Aluminum Discharge Grilles

Model 51DV Vertical Front Blades

Double Deflection Supply Grilles and Registers are recommended for application in systems requiring maximum flexibility. The front set of blades has the greatest effect on the air pattern. Vertical front blades control the spread and throw distance of the air pattern. Horizontal rear blades control the rise and drop of the air pattern, typically directing warm air downwards or cool air upwards along the ceiling.

The combination of streamlined 'teardrop' shaped blades and 3/4" (19) spacing maintains a high effective free area average capacity of 75%, which minimizes outlet velocity, reduces pressure drop and assures quiet operation.

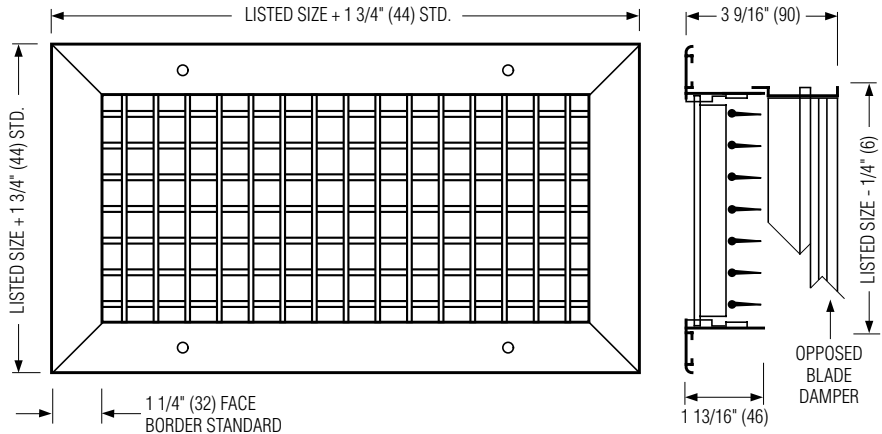

Features

- High quality extruded aluminum construction.
- 1 1/4" (32) wide face border with a 1" (25) overlap margin standard, furnished with countersunk screw holes and mounting screws.
- Rigid, heavy gauge extruded frames with reinforced mitered corners.
- Streamlined shaped extruded blades on 3/4" (19) centers. Blades positively hold deflection setting under all conditions of velocity and pressure.
- Adjustable air pattern - Blades are friction pivoted and easily adjusted to provide desired spread or deflection.
- An opposed blade damper is required on one supply grille

for units with two supply outlets and on two supply grilles for units with three supply outlets for field balancing.

- Grilles are shipped loose for field installation unless integral full cover panels are specified (optional).
- For "top outlet" fan coil units which are ducted to a discharge grille at a remote location(s), Model 51DV Grilles and Model 51DV-O Registers are available in sizes from 4" x 4" to 48" x 36" (102 x 102 to 1219 x 914) to suit airflow capacity and performance requirements.
- AW Appliance White powder coat baked enamel finish is standard. Other finishes are available.

Performance Data

Unit	Nominal		Single Supply			Double Supply			Triple Supply			
	Size	CFM	I/s	W x H	Throw	NC	W x H	Throw	NC	W x H	Throw	NC
3	360	170			10-16-30	<20		-	-	-	-	-
5	550	260	16 x 10 (406 x 254)	18-27-38	<20	16 x 10 (406 x 254)	8-12-24	<20	-	-	-	-
6	600	283		20-29-40	<20		9-15-29	<20	-	-	-	-
8	900	425	18 x 10 (457 x 254)	27-33-46	27	18 x 10 (457 x 254)	14-20-33	<20	-	-	-	-
10	1000	472		28-34-48	30		15-22-34	<20	-	-	-	-
12	1250	590	22 x 10 (559 x 254)	33-40-57	32	22 x 10 (559 x 254)	19-29-41	<20	22 x 10 (559 x 254)	11-18-33	<20	<20
15	1500	708		37-45-64	37		22-31-45	<20		13-21-37	<20	<20
19	1900	897	28 x 10 (711 x 254)	40-49-70	37	28 x 10 (711 x 254)	24-35-49	<20	28 x 10 (711 x 254)	14-22-40	<20	<20
21	2150	1015		43-53-75	41		26-38-52	<20		17-26-43	<20	<20

NOTES:

1. Performance data is based on double deflection grille without opposed blade damper. Data is for grille only and does not include fan coil unit sound.
2. Double and triple supply grilles may be ordered the same size (as shown) or smaller than single supply grille.
3. NC corrections for open damper and blade deflection:
Without damper: 22 1/2° + 2 NC, 45° + 7 NC.
With damper: 22 1/2° + 6 NC, 45° + 11 NC.
(A throttling damper may add an additional 5 – 10 NC)
4. Throws are given for terminal velocities of 150,100 and 50 fpm under isothermal conditions at 0° deflection.
5. Throw corrections for blade deflection:
22 1/2° Multiply listed throw values by x 0.80
45° Multiply listed throw values by x 0.50
6. Data derived from tests conducted in accordance with ASHRAE Standard 70.

Model Series 39VH & 39L • Outside Air (IAQ) Inlet Dampers

A
VERTICAL HI-RISE/STACK FAN COIL UNITS

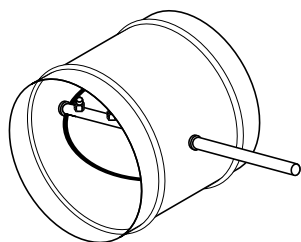

MOTORIZED DAMPER

WITH 2-position OPEN/
CLOSED ACTUATOR 4"
(102) DIA. NOMINAL

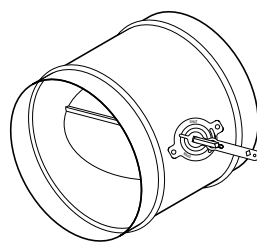

MANUAL BALANCING DAMPER

4" (102) DIA. NOMINAL

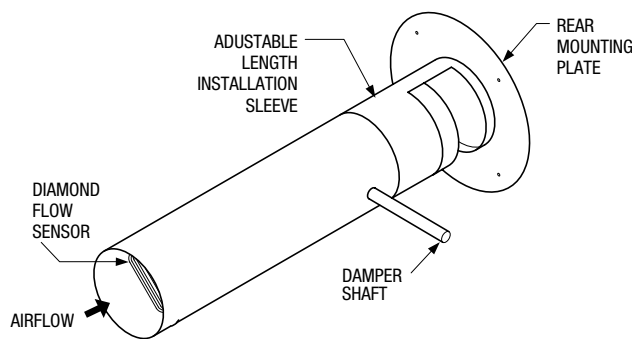

PRESSURE INDEPENDENT DAMPER

WITH FLOW SENSOR AND MODULATING
ACTUATOR
4" (102) DIA. NOMINAL

NOTES:

1. Outside Air Inlet Damper available on Model Series 39VH and 39L.
2. Outside Air location may be on the right or left side of the unit (opposite from any side riser).
3. Dampers are undersized 1/8" (3) for ducted connection to nominal duct.

Stainless Steel Flexible Hoses

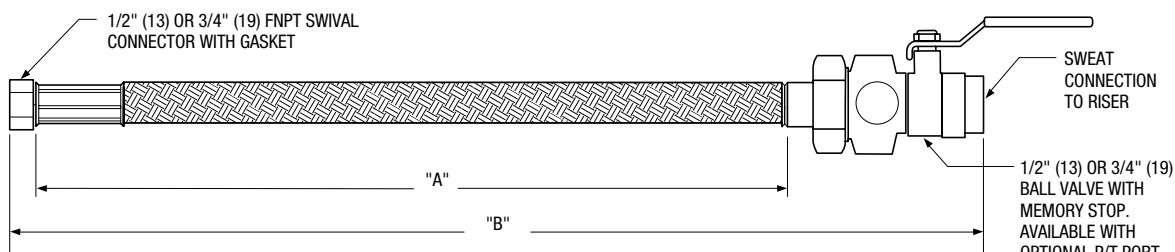

Piping packages on Nailor Vertical Hi-Rise fan coil units feature 1/2" (13) or 3/4" (19) flexible stainless steel braided hoses on all 2-pipe and 4-pipe configurations as standard. Flexible hose kits provide significant benefits over hard piping during installation, commissioning, operation and maintenance.

- Flexible hoses allow for easy field configuration of left hand, right hand and back riser connections without the need for thermal cutting and joining of piping, saving time and money.
- Permit looping the pipe lines and bypassing the coil in order to flush the system for debris prior to operation.
- Flexible hoses allow for thermal expansion and contraction.
- Threaded swivel end connections facilitate coil and piping package removal for service and repair.
- Pressure rating: 375 PSIG @ 250°F (450 PSI test pressure).
- Flame and Smoke Spread meet 25/50 per UL 723.
- Ball valve with memory stop allows the ball valve to be closed and returned to the balance setting position, without re-testing the system.

Available Hose Lengths		
No.	"A" inches (mm)	"B" inches (mm)
1	18 (457)	22 (559)
2	24 (610)	28 (711)
3	36 (914)	40 (1016)
4	48 (1219)	52 (1321)

Model Series 39VH & 39L • Riser Selection and Data

Riser Application and Sizing

Technical information on heat transfer, fluid flow and pipe sizing can be found in the ASHRAE Fundamentals Handbook and various other technical documents and publications. Some of the factors affecting riser application and sizing are noise, tube erosion and economics. The friction loss for risers chart displays riser tube diameter sizes as a function of flow (GPM), friction loss and water velocity. For maximum riser velocity and pressure drop per 100 ft., refer to latest ASHRAE Fundamentals Handbook, Pipe Sizing Chapter. Riser sizes can be of a single diameter on low rise buildings, or varying sizes on medium to high rise buildings. Generally, riser copper type, size, length and insulation thickness are determined by the location of the fan coil unit in the building. Chilled and hot water risers are available in Type K, L or M copper, varying diameters from 3/4" (19) to 3" (76) and with either 1/2" (13) or 3/4" (19) thick closed cell foam insulation. Drain risers are available in Type M copper, varying diameters from 3/4" (19) to 3" (76) and with either 1/2" (13) or 3/4" (19) thick closed cell foam insulation.

Friction Loss for Risers Chart

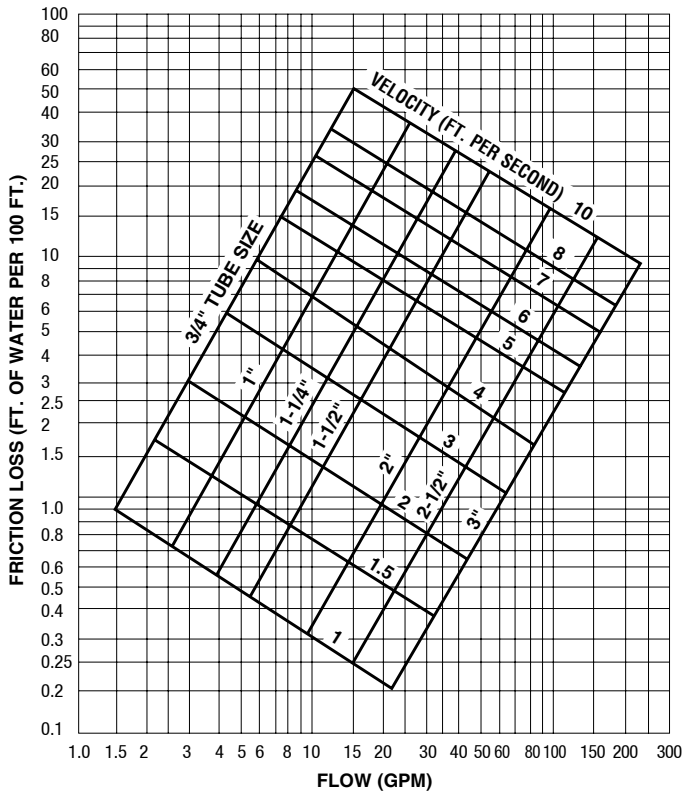

Riser Expansion

Generally, in medium to high rise buildings, allowance must be made for pipe expansion. Model Series 39 Hi-Rise fan coil units are furnished with hoses which act as expansion loops integral to the unit. The hose will allow for +/- 1 1/2" (38) of riser expansion and contraction. Additional expansion compensation must be made in the riser system in the field where movement is expected to exceed the factory allowances. Technical information on pipe expansion, contraction and anchoring can be found in the ASHRAE HVAC Systems and Equipment Handbook and various other technical documents and publications.

Risers may not be anchored to fan coil units. They must be anchored to structure.

Riser Expansion Chart

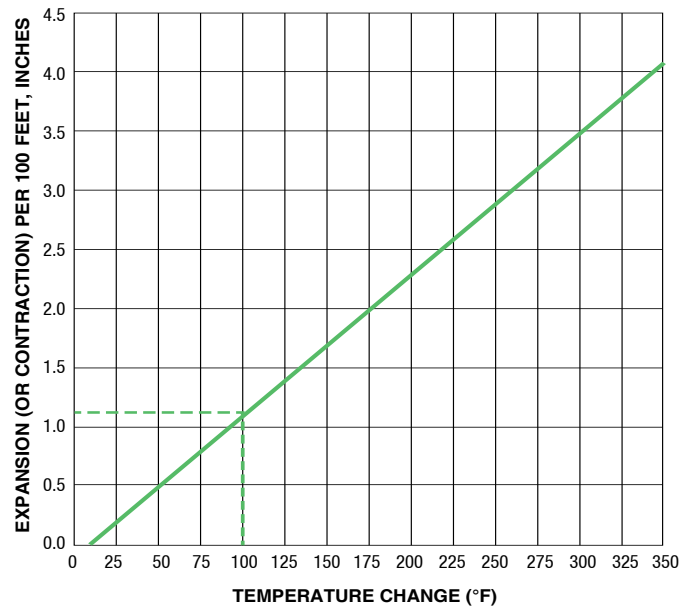

The above chart shows the change in length per 100 feet of copper tube with temperature. The following equation is used to calculate riser expansion.

$$\text{Temperature Rise (°F)} \times \text{Length (ft.)} \times 12 \text{ (in. per ft.)} \times 0.0000094 \text{ (in. per in. per °F)} = \text{Expansion (in.)}$$

For example:

The expansion of each 100 ft. of length of any size tube heated from room temperature 70°F to 170°F (a 100°F rise) is 1.128 in.

$$100^\circ\text{F} \times 100 \text{ ft.} \times 12 \text{ in./ft.} \times 0.0000094 \text{ in./in./}^\circ\text{F} = 1.128 \text{ in.}$$

Model Series 39VH & 39L

Standard Capped Supply/Return Risers • Full Length & Reducing

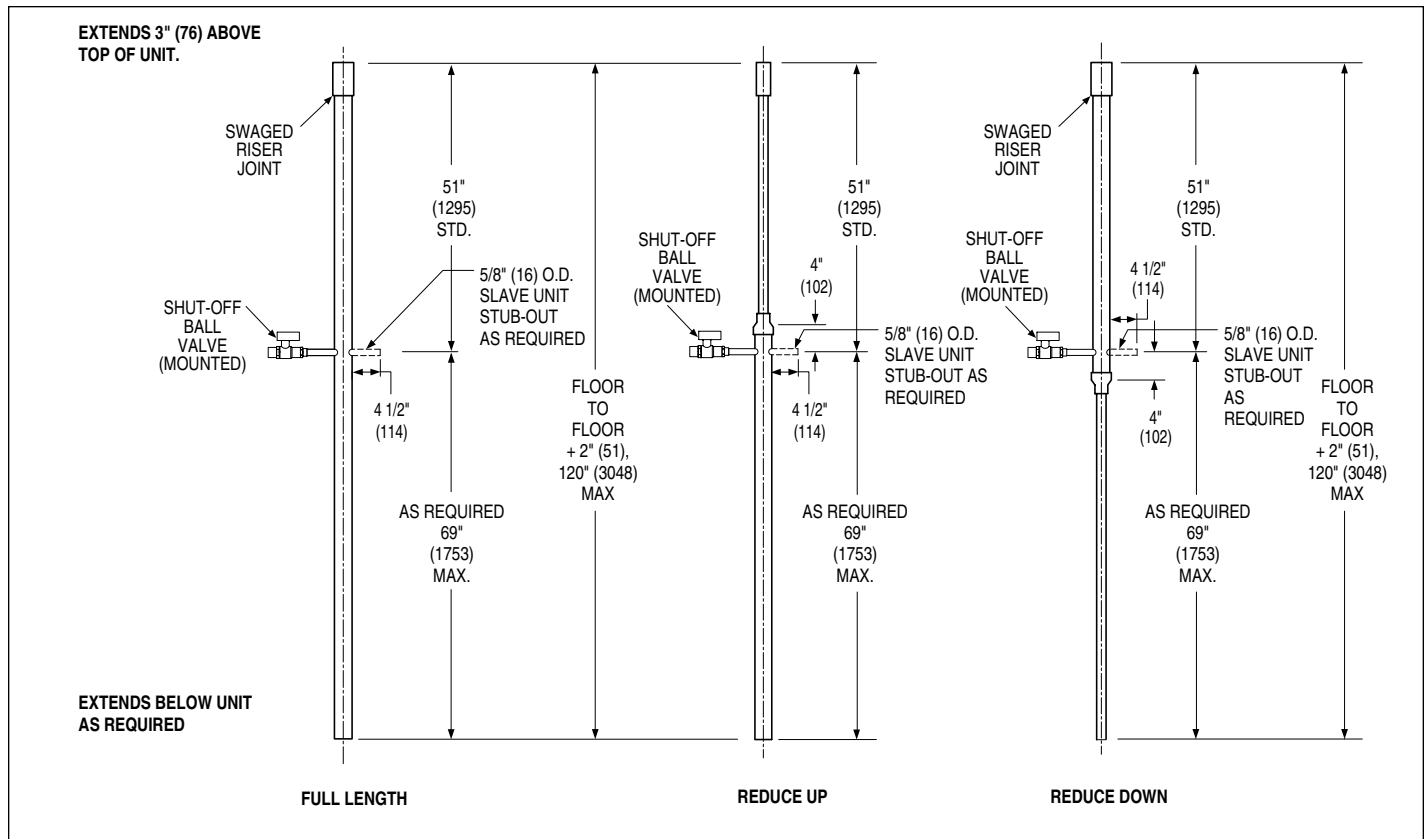

A
VERTICAL HI-RISE/STACK FAN COIL UNITS

Standard Capped Supply/Return Risers • Full Length, Reducing & Capped

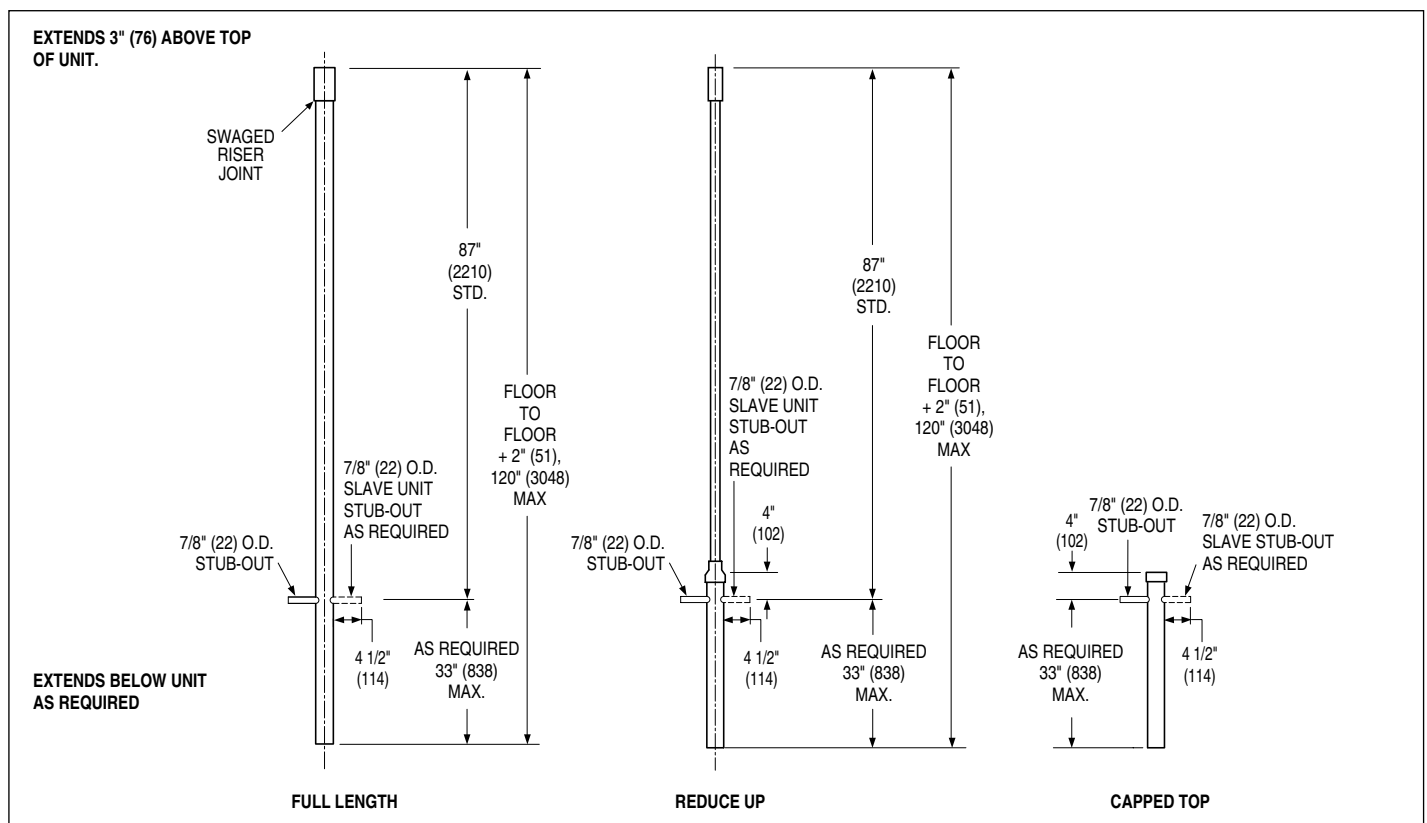

Model Series 39VH • Standard Capped Supply/Return Risers

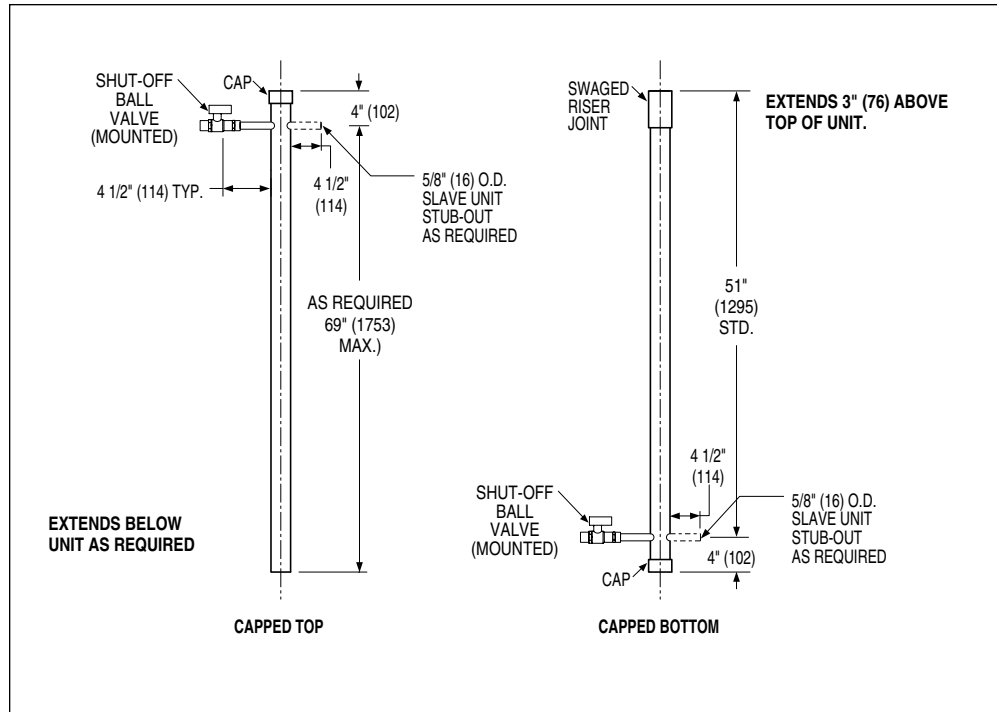

Swaged Riser Joint Detail

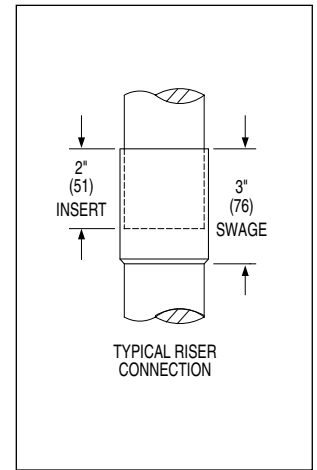

NOTES:

1. Supply and Return Risers are available from 3/4" (19) to 3" (76) diameter in Type K (heavy wall), Type M (medium wall) and Type L (light wall) copper with either 1/2" (13) or 3/4" (19) insulation (flexible closed cell foam).
2. Risers are available "full length" (one piece), "capped top", "capped bottom", "reduced up" and "reduced down". Risers are reduced one nominal pipe size only.
3. Drain Risers are Type M copper only and maximum 1 1/4" diameter with maximum 1/2" (13) insulation. Drain risers are available in "full length", "reduced up" and "capped top" only.
4. Risers extend 3" (76) above the top of the unit as standard. The riser extension below the bottom of the unit is variable and dependent upon the floor to floor height for the building installation. Stacked unit risers are designed with a swaged socket connection in the top to accommodate 2" (51) of tail piece insertion from the riser above. Connections require field brazing.
5. Risers are ordered by specifying the exact overall length. The required overall riser length = Floor to Floor height + 2" (51).
6. Maximum riser length is 120" (3048). Minimum is 100" (2540). If required riser length exceeds 120" (3048), which represents a floor to floor height of 118" (2997), riser extensions will be required. Consult Nailor.
7. 39L Series risers are available 92" (2337) to 112" (2845) long. (See submittal drawing for dimensional details).
8. Factory mounted risers are standard. Risers may be ordered and shipped in advance to facilitate field installation.
9. Total width of riser assembly (pipes plus insulation) cannot exceed unit cabinet width for factory mounted risers. This should be reviewed carefully for 4-pipe system with risers larger than 2" (51) dia. for unit sizes 3 – 10.

Model Series 39VH, 39L & 39MU • PSC Motor Fan Performance Curves Airflow vs. Downstream Static Pressure

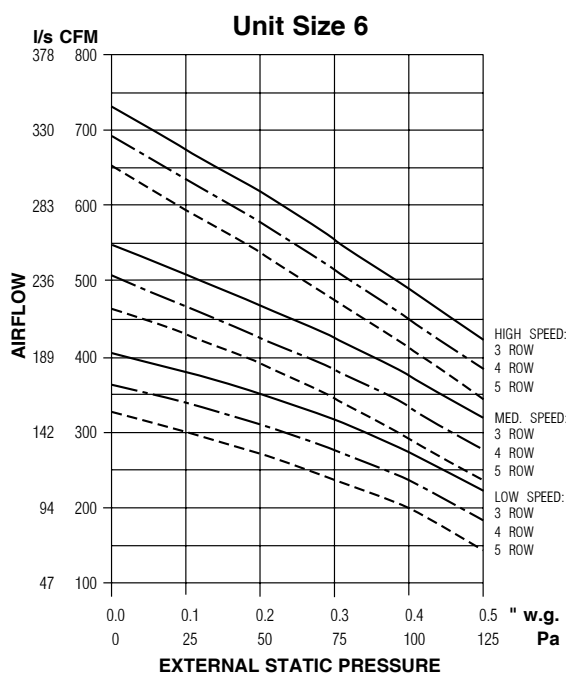
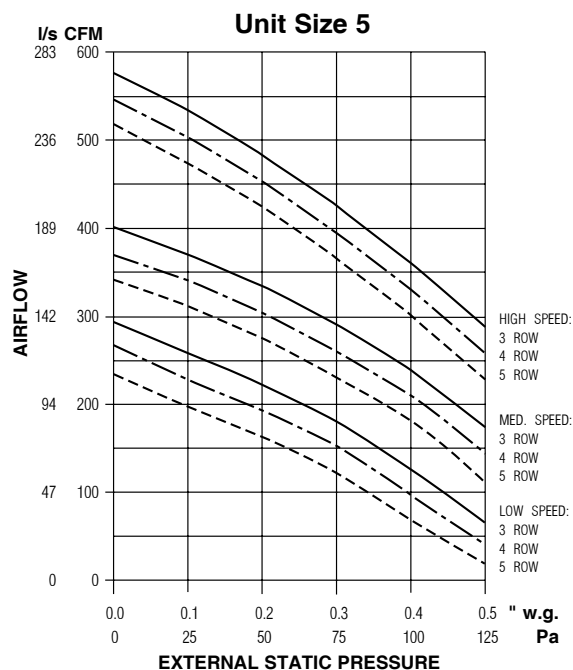
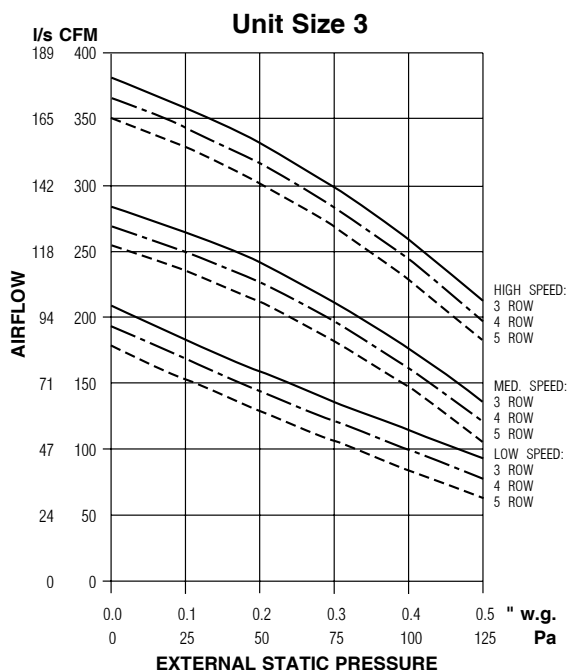

PSC Motor Fan Notes:

1. Fan coil units equipped with permanent split capacitor (PSC) motors are of the three speed type with separate taps (High, Medium and Low) which provide variable horsepower outputs. Commonly, units are selected and sized on a conservative basis and actual airflow requirements are lower than specified. When this is the case, the unit fan motor can be run at low or medium speed, reducing power consumption and operating cost.
2. Fan curves are applicable to both the total number of rows for a 2-pipe system chilled water or changeover coil and the total number of rows for a 4-pipe system chilled/hot water combination coil.
3. All fan curves shown are applicable to 120, 208, 240 and 277 volt, single phase motors and include internal losses for cabinet, return grille, electric heater, 3, 4 or 5 row water coil and clean 1" (25) throwaway filter. See page A28 for electrical motor performance data.
4. The operating point for units with standard grilles is 0.0 w.g. ESP. Additional external static pressure should be taken into account for top outlet units with remote ducted grilles, MERV rated filters and general filter loading.
5. For one (1) or two (2) row hot water coils (-W heating units) performance will be slightly better. See SelectWorks for performance data Characteristics.
6. Filter pressure drops table shown on page A29.

A

VERTICAL HI-RISE/STACK FAN COIL UNITS

Model Series 39VH, 39L & 39MU • PSC Motor Fan Performance Curves

Airflow vs. Downstream Static Pressure

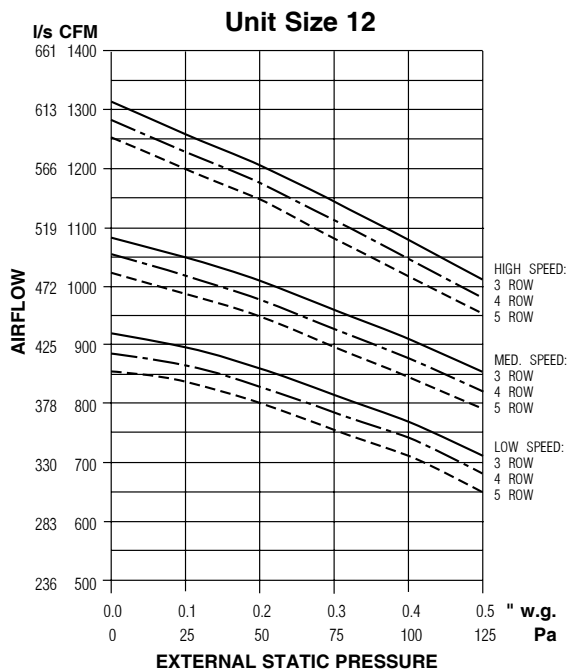
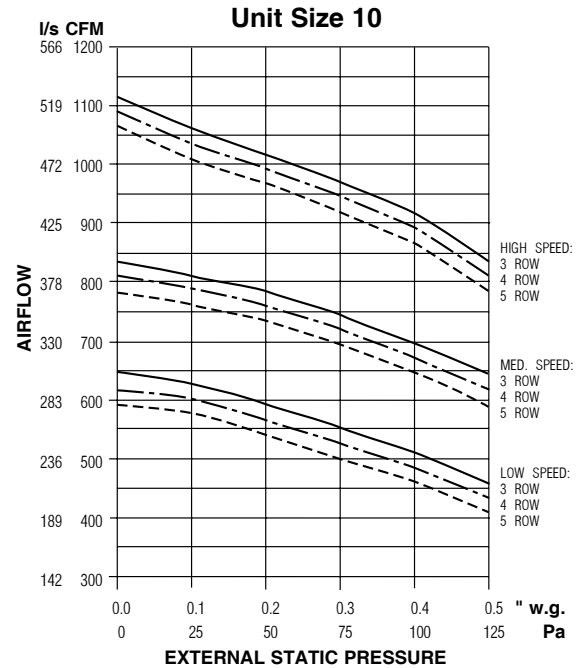
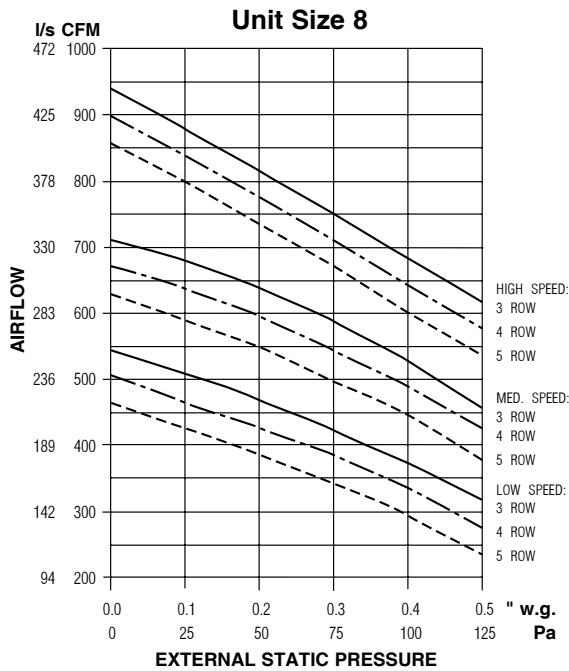

PSC Motor Fan Notes:

1. Fan coil units equipped with permanent split capacitor (PSC) motors are of the three speed type with separate taps (High, Medium and Low) which provide variable horsepower outputs. Commonly, units are selected and sized on a conservative basis and actual airflow requirements are lower than specified. When this is the case, the unit fan motor can be run at low or medium speed, reducing power consumption and operating cost.
2. Fan curves are applicable to both the total number of rows for a 2-pipe system chilled water or changeover coil and the total number of rows for a 4-pipe system chilled/hot water combination coil.
3. All fan curves shown are applicable to 120, 208, 240 and 277 volt, single phase motors and include internal losses for cabinet, return grille, electric heater, 3, 4 or 5 row water coil and clean 1" (25) throwaway filter. See page A28 for electrical motor performance data.
4. The operating point for units with standard grilles is 0.0 w.g. ESP. Additional external static pressure should be taken into account for top outlet units with remote ducted grilles, MERV rated filters and general filter loading.
5. For one (1) or two (2) row hot water coils (-W heating units) performance will be slightly better. See SelectWorks for performance data Characteristics.
6. Filter pressure drops table shown on page A29.

A

VERTICAL HI-RISE/STACK FAN COIL UNITS

Model Series 39VH, 39L & 39MU • PSC Motor Fan Performance Curves Airflow vs. External Static Pressure

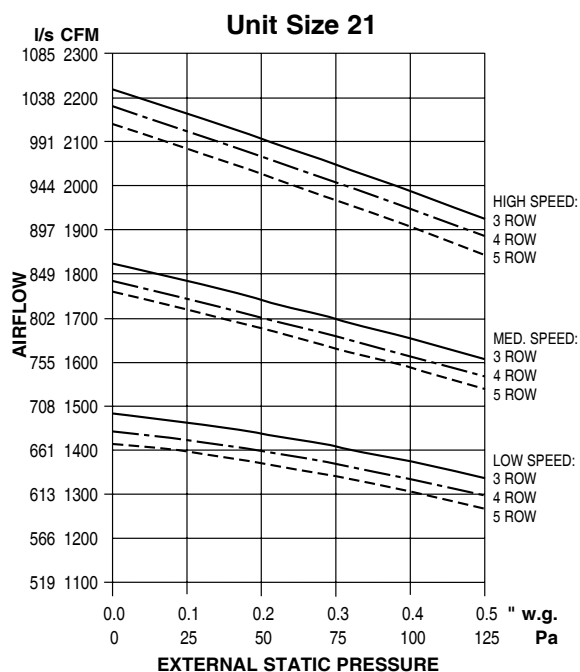
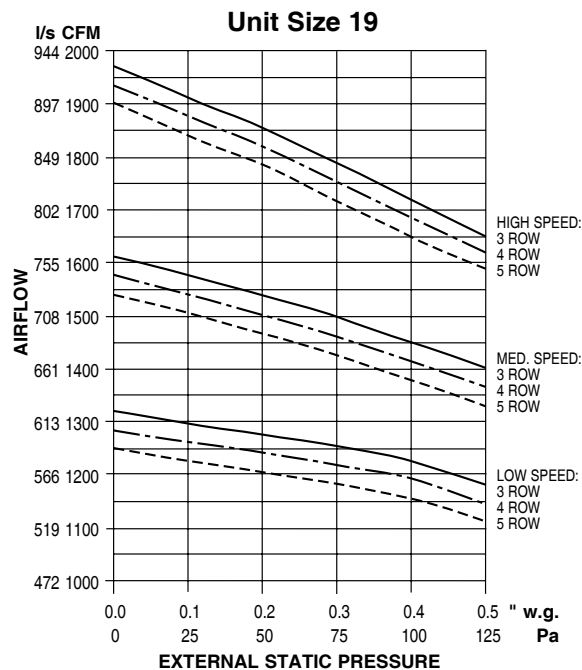
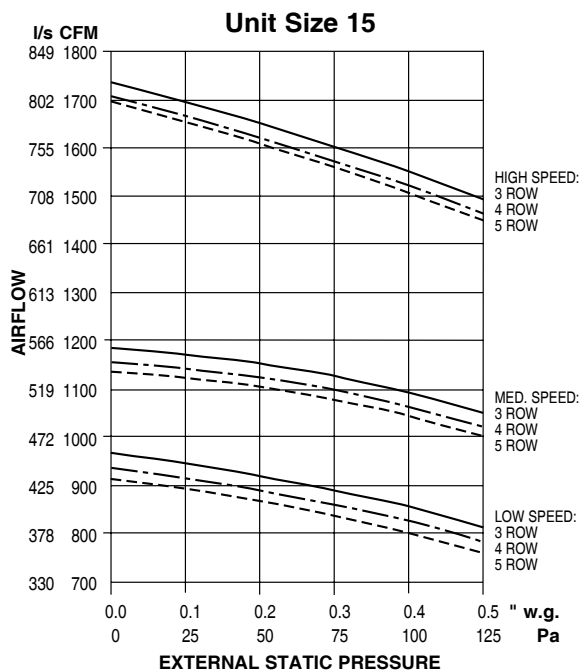

PSC Motor Fan Notes:

1. Fan coil units equipped with permanent split capacitor (PSC) motors are of the three speed type with separate taps (High, Medium and Low) which provide variable horsepower outputs. Commonly, units are selected and sized on a conservative basis and actual airflow requirements are lower than specified. When this is the case, the unit fan motor can be run at low or medium speed, reducing power consumption and operating cost.
2. Fan curves are applicable to both the total number of rows for a 2-pipe system chilled water or changeover coil and the total number of rows for a 4-pipe system chilled/hot water combination coil.
3. All fan curves shown are applicable to 120, 208, 240 and 277 volt, single phase motors and include internal losses for cabinet, return grille, electric heater, 3, 4 or 5 row water coil and clean 1" (25) throwaway filter. See page A28 for electrical motor performance data.
4. The operating point for units with standard grilles is 0.0 w.g. ESP. Additional external static pressure should be taken into account for top outlet units with remote ducted grilles, MERV rated filters and general filter loading.
5. For one (1) or two (2) row hot water coils (-W heating units) performance will be slightly better. See SelectWorks for performance data Characteristics.
6. Filter pressure drops table shown on page A29.

A

VERTICAL HI-RISE/STACK FAN COIL UNITS

Model Series 39VH, 39L & 39MU • 3-Speed ECM • Fan Performance Curves

Airflow vs. External Static Pressure

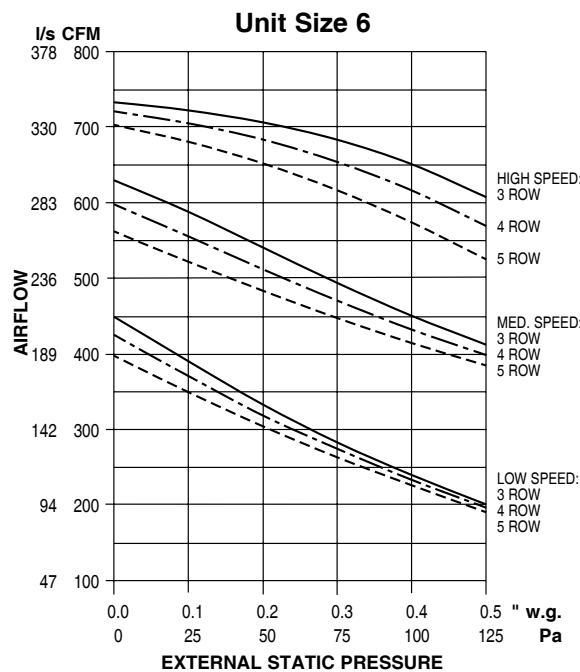
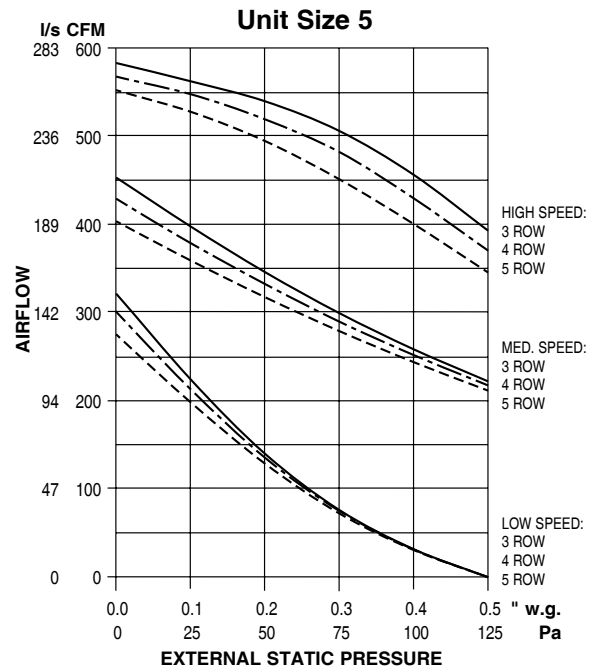
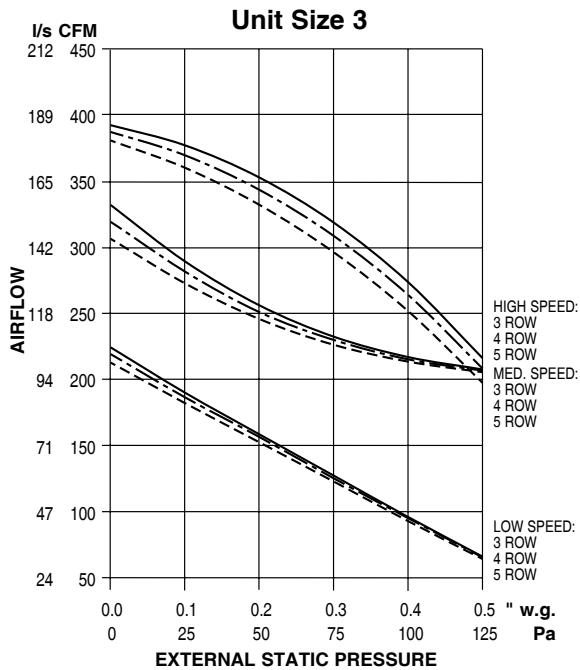

3-Speed ECM Fan Notes:

1. Fan coil units equipped with 3-Speed ECM are of the three speed type with separate taps (High, Medium and Low) which provide variable horsepower outputs. Commonly, units are selected and sized on a conservative basis and actual airflow requirements are lower than specified. When this is the case, the unit fan motor can be run at low or medium speed, reducing power consumption and operating cost.
2. Fan curves are applicable to both the total number of rows for a 2-pipe system chilled water or changeover coil and the total number of rows for a 4-pipe system chilled/hot water combination coil.
3. All fan curves shown are applicable to 120, 208, 240 and 277 volt, single phase motors and include internal losses for cabinet, return grille, electric heater, 3, 4 or 5 row water coil and clean 1" (25) throwaway filter. See page A28 for electrical motor performance data.
4. The operating point for units with standard grilles is 0.0 w.g. ESP. Additional external static pressure should be taken into account for top outlet units with remote ducted grilles, MERV rated filters and general filter loading.
5. For one (1) or two (2) row hot water coils (-W heating units) performance will be slightly better. See SelectWorks for performance data Characteristics.
6. Filter pressure drops table shown on page A29.

A

VERTICAL HI-RISE/STACK FAN COIL UNITS

Model Series 39VH, 39L & 39MU • 3-Speed ECM • Fan Performance Curves Airflow vs. External Static Pressure

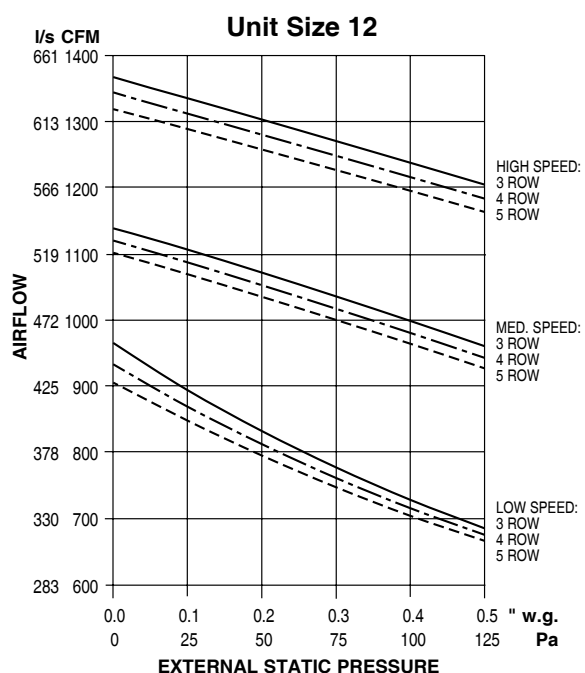
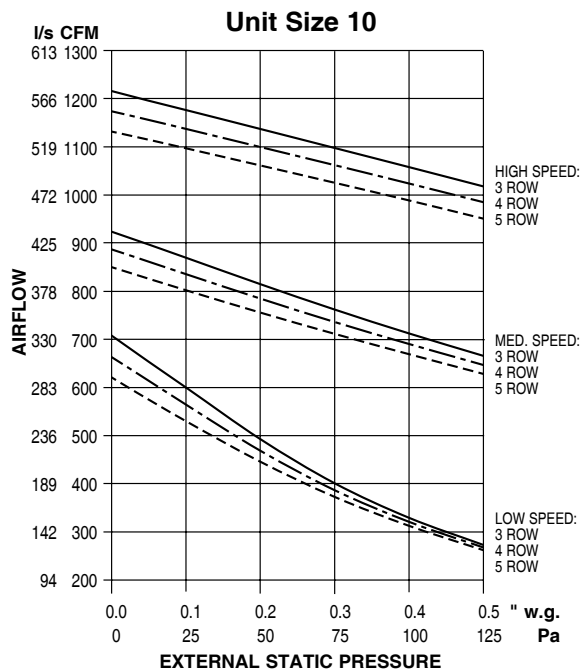
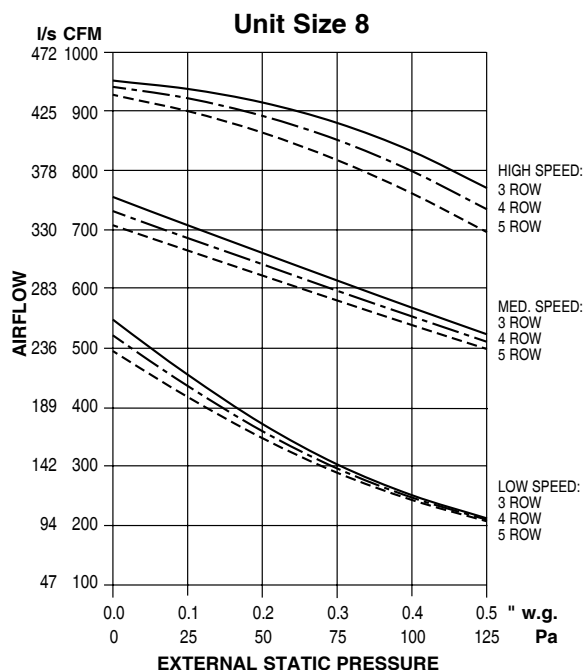

3-Speed ECM Fan Notes:

1. Fan coil units equipped with 3-Speed ECM are of the three speed type with separate taps (High, Medium and Low) which provide variable horsepower outputs. Commonly, units are selected and sized on a conservative basis and actual airflow requirements are lower than specified. When this is the case, the unit fan motor can be run at low or medium speed, reducing power consumption and operating cost.
2. Fan curves are applicable to both the total number of rows for a 2-pipe system chilled water or changeover coil and the total number of rows for a 4-pipe system chilled/hot water combination coil.
3. All fan curves shown are applicable to 120, 208, 240 and 277 volt, single phase motors and include internal losses for cabinet, return grille, electric heater, 3, 4 or 5 row water coil and clean 1" (25) throwaway filter. See page A28 for electrical motor performance data.
4. The operating point for units with standard grilles is 0.0 w.g. ESP. Additional external static pressure should be taken into account for top outlet units with remote ducted grilles, MERV rated filters and general filter loading.
5. For one (1) or two (2) row hot water coils (-W heating units) performance will be slightly better. See SelectWorks for performance data Characteristics.
6. Filter pressure drops table shown on page A29.

Model Series 39VH, 39L & 39MU • 3-Speed ECM • Fan Performance Curves

Airflow vs. External Static Pressure

A

VERTICAL HI-RISE/STACK FAN COIL UNITS

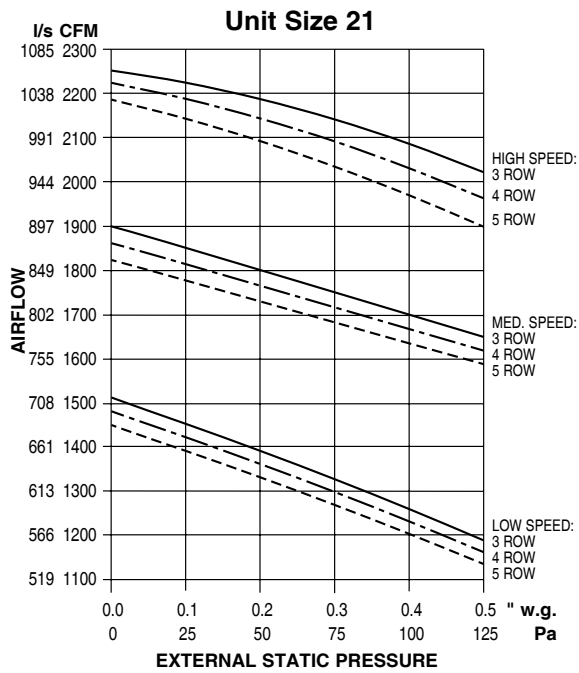
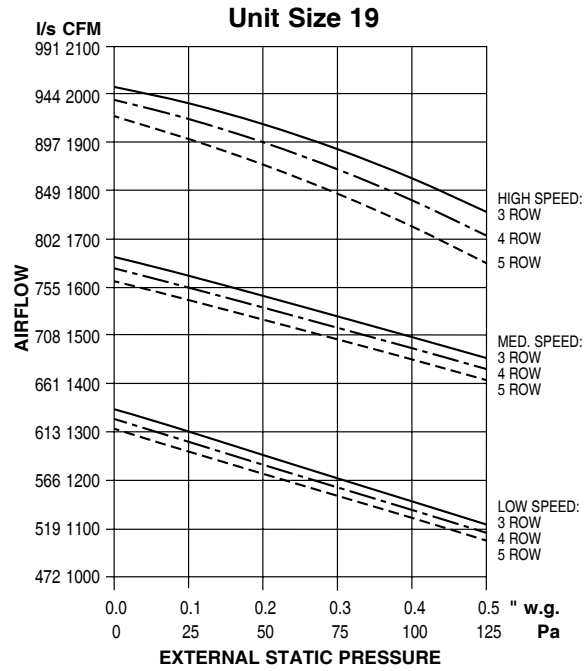
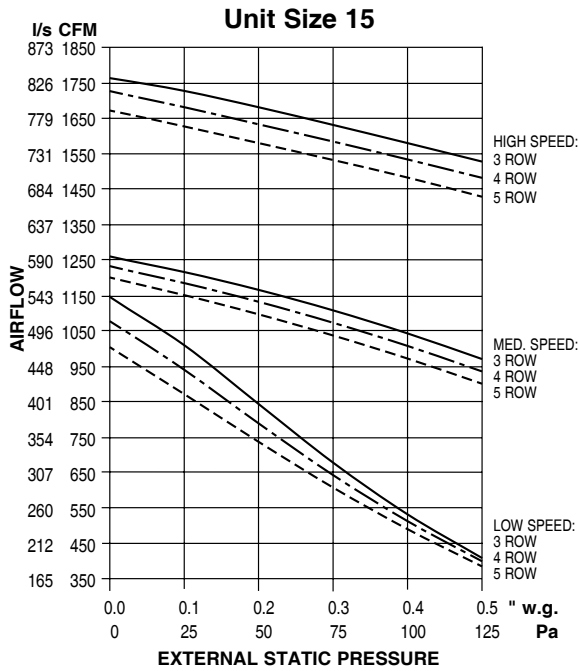

3-Speed ECM Fan Notes:

1. Fan coil units equipped with 3-Speed ECM are of the three speed type with separate taps (High, Medium and Low) which provide variable horsepower outputs. Commonly, units are selected and sized on a conservative basis and actual airflow requirements are lower than specified. When this is the case, the unit fan motor can be run at low or medium speed, reducing power consumption and operating cost.
2. Fan curves are applicable to both the total number of rows for a 2-pipe system chilled water or changeover coil and the total number of rows for a 4-pipe system chilled/hot water combination coil.
3. All fan curves shown are applicable to 120, 208, 240 and 277 volt, single phase motors and include internal losses for cabinet, return grille, electric heater, 3, 4 or 5 row water coil and clean 1" (25) throwaway filter. See page A28 for electrical motor performance data.
4. The operating point for units with standard grilles is 0.0 w.g. ESP. Additional external static pressure should be taken into account for top outlet units with remote ducted grilles, MERV rated filters and general filter loading.
5. For one (1) or two (2) row hot water coils (-W heating units) performance will be slightly better. See SelectWorks for performance data Characteristics.
6. Filter pressure drops table shown on page A29.

Model Series 39VH, 39L & 39MU • EPIC ECM Motor • Fan Performance Curves Airflow vs. External Static Pressure

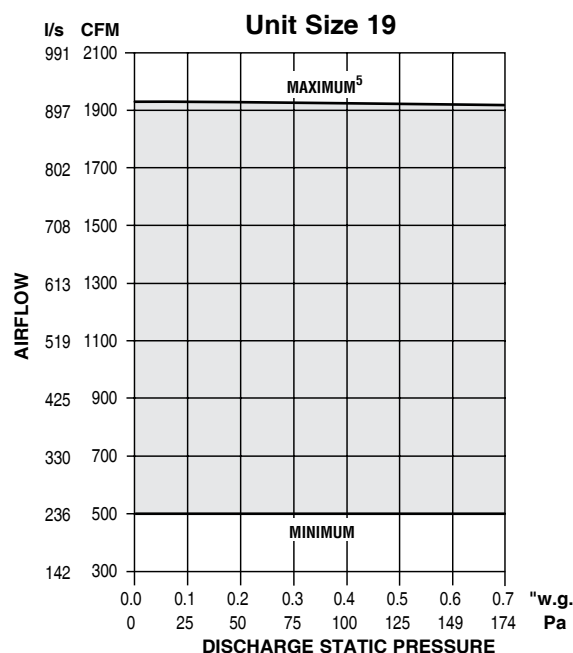
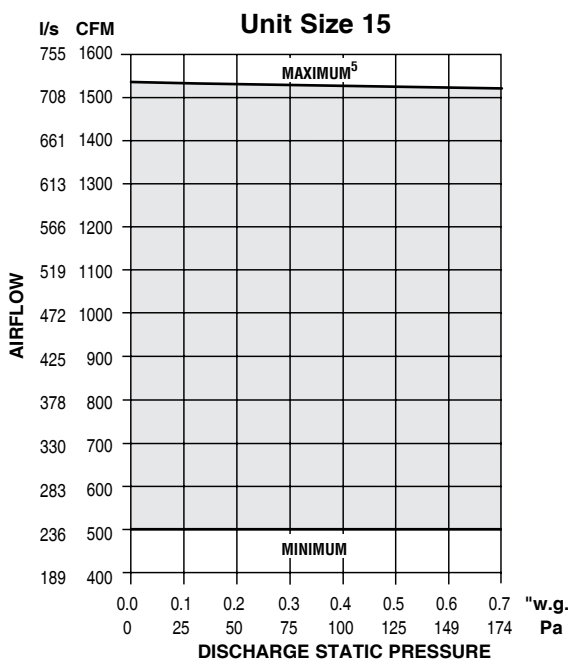
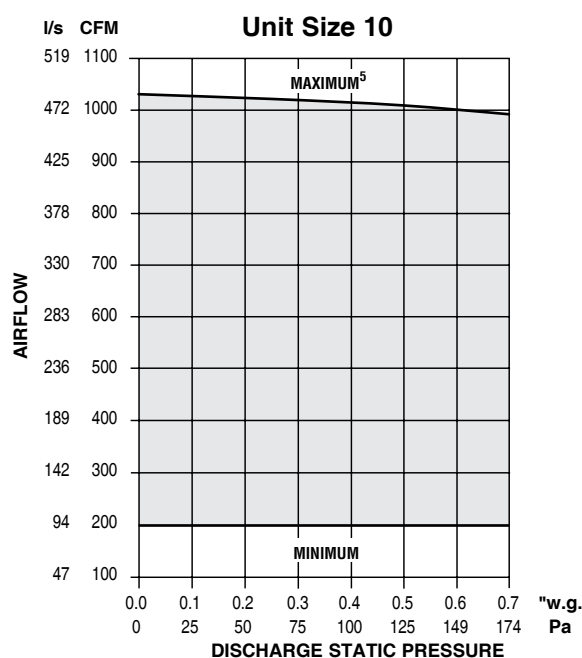
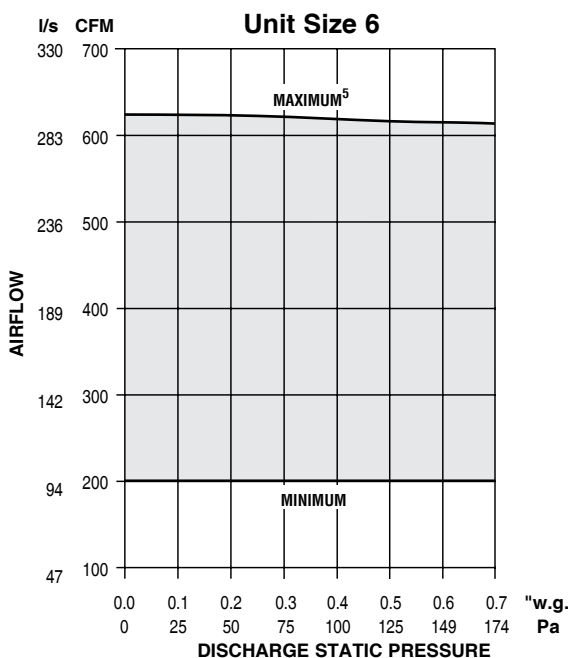

EPIC ECM Notes:

1. The EPIC ECM is a pressure independent constant volume device at set point and airflow does not vary with changing static pressure condition. The motor compensates for any changes in static pressure such as filter loading. Variations in airflow are generated by the controls which reset the fan airflow based on room demand. (See control sequence).
2. Airflow can be set to operate at any point within shaded area under the selected water coil curve using the EPIC volume controller provided.
3. Engineered Comfort Fan Coil units featuring the optional EPIC ECM have considerably wider turn-down ratios than conventional PSC motors. Hence, a reduced number of unit sizes will provide the same fan airflow range when compared

with fan coils equipped with PSC motors. A reduction in the number of different fan coil sizes, required on a typical project, simplifies design lay-out, installation and reduces inventory of field service parts.

4. Fan curves shown are applicable to 120/208/240 and 277 volt, single phase EPIC ECM (motors). See page A28 for electrical motor performance data.
5. The maximum curve represents unit performance with a 3-row coil. For one (1) and two (2) row coils (heating only units) performance will be slightly better. Four (4) and five (5) coils are comparable to the maximum curves. See SelectWorks for performance data Characteristics.
6. Filter pressure drops table shown on page A29.

Model Series 39VH, 39L & 39MU • Performance Data Electrical Motor Characteristics

Unit Size	Voltage	No. of Fans/Motors	EPIC ECM		3-Speed ECM		PSC Motor	
			FLA	Full Load Watts	FLA	Full Load Watts	FLA	HP
3	120	1/1			1.6		1.8	1/10
	208	1/1			1.1	105	0.7	
	240	1/1			1.1		0.7	
	277	1/1			1.0		0.6	
5	120	1/1			2.0		140	1.9
	208	1/1			1.4	0.7		
	240	1/1			1.4	0.7		
	277	1/1			1.2	0.6		
6	120	1/1	3.6	260	2.5	180	2.7	1/6
	208	1/1	2.3		1.8		1.1	
	240	1/1	2.2		1.7		1.1	
	277	1/1	2.0		1.6		0.9	
8	120	1/1			3.4	250	2.7	1/6
	208	1/1			2.4		1.1	
	240	1/1			2.3		1.1	
	277	1/1			2.1		0.9	
10	120	1/1	6.8	520	4.7	350	4.7	1/3
	208	1/1	4.0		3.3		2.0	
	240	1/1	4.3		3.2		2.0	
	277	1/1	3.6		2.9		1.8	
12	120	1/1			5.3	380	5.5	1/3
	208	1/1			3.7		2.6	
	240	1/1			3.7		2.6	
	277	1/1			3.3		2.1	
15	120	1/1	8.7	710	8.0	590	3.5	1/2
	208	1/1	5.8		5.6		3.8	
	240	1/1	5.4		5.5		3.8	
	277	1/1	4.6		5.0		2.8	
19	120	1/1	12.7	1060	11.9	935	4.3	3/4
	208	1/1	8.5		8.3		5.1	
	240	1/1	7.8		8.2		5.1	
	277	1/1	6.5		7.4		4.1	
21	120	1/1			12.5	1010	4.2	3/4
	208	1/1			8.8		5.1	
	240	1/1			8.6		5.1	
	277	1/1			7.8		4.1	

The FLA and watts are shown at the maximum setting for selected motor type and unit size. The EPIC ECM motor will provide a much lower amp and watt consumption under application conditions. Refer to SelectWorks selection software for application specific data.

A

VERTICAL HI-RISE/STACK FAN COIL UNITS

Model Series 39VH, 39L & 39MU

Filter Pressure Drop Adjustments (in w.g.)

Unit Size	Airflow		Velocity		Filter Type		Filter Size W x H
	CFM	l/s	FPM	m/s	1" (25) Throwaway	1" (25) MERV 8	
3	380	179	248	1.260	0.05	0.165	16 3/4 x 13 1/8 (425 x 333)
	285	134	186	0.945	0.025	0.115	
	210	99	137	0.696	0.006	0.076	
5	575	271	376	1.910	0.101	0.267	
	400	189	261	1.326	0.055	0.176	
	295	139	193	0.980	0.028	0.121	
6	730	344	477	2.423	0.142	0.348	
	550	260	359	1.824	0.094	0.254	
	410	193	268	1.361	0.058	0.181	
8	935	441	362	1.839	0.096	0.256	24 x 15 1/2 (6110 x 394)
	715	337	277	1.407	0.062	0.188	
	550	260	213	1.082	0.036	0.137	
10	1115	526	432	2.195	0.124	0.312	
	835	394	324	1.646	0.08	0.225	
	650	307	252	1.280	0.051	0.168	
12	1315	621	353	1.793	0.092	0.248	29 x 18 1/2 (737 x 470)
	1080	510	290	1.473	0.067	0.198	
	920	434	247	1.255	0.049	0.164	
15	1735	819	465	2.362	0.137	0.339	
	1185	559	318	1.615	0.078	0.221	
	970	458	260	1.321	0.055	0.174	
19	1975	932	401	2.037	0.111	0.287	29 x 24 1/2 (737 x 622)
	1615	762	328	1.666	0.082	0.228	
	1315	621	267	1.356	0.057	0.180	
21	2220	1048	450	2.286	0.131	0.327	
	1820	859	369	1.875	0.098	0.262	
	1480	698	300	1.524	0.071	0.207	

NOTES:

1. Pressure drop based on clean filters. Using any type of filter will lower unit airflow.
2. To determine fan airflow with the addition of a filter, add the filter pressure drop to the external static pressure on the fan curve or use Selectworks.

Model Series 39VH, 39L & 39MU • Sound Power Performance Data

Tested Per AHRI 350 – 2000 — Reverberation Room										
Unit Size	Airflow		Octave Bands / Frequency (Hz) / Sound Power (Lw)							
	cfm	l/s	2	3	4	5	6	7	8	LWA
			125	250	500	1k	2k	4k	8k	
6	110	52	—	—	24	19	—	—	—	24
	200	94	50	38	35	29	—	—	—	37
	300	142	50	48	42	34	30	27	—	43
	400	189	57	52	47	40	34	30	—	48
	600	283	62	57	52	46	41	36	27	54
10	300	142	48	47	40	31	25	18	—	41
	500	236	59	56	50	43	35	29	20	51
	600	283	63	60	53	46	39	32	26	54
	800	378	69	66	58	53	47	41	33	61
	900	425	72	69	61	56	51	46	37	64
	1000	472	74	71	64	59	54	50	42	66
15	600	283	58	52	47	39	32	—	—	48
	800	378	63	58	52	46	41	35	—	54
	1000	472	68	63	57	52	46	41	31	60
	1200	566	72	68	60	56	52	48	39	64
	1300	613	74	69	61	58	54	50	41	65
19	1500	708	78	74	66	63	59	56	48	70
	500	236	52	49	42	36	34	34	38	46
	700	330	57	54	49	42	37	34	38	50
	1000	472	64	59	56	50	46	39	38	57
	1300	613	71	65	62	57	53	48	41	63
19	1600	755	75	71	65	63	59	55	47	69
	1900	897	79	75	69	67	64	61	54	73



Performance Notes:

1. Sound data was taken with 30% pleated filter in place.
2. Sound power levels are in decibels, dB re 10⁻¹² watts.
3. LWA is the A-Weighted Sound Power Level, expressed in decibels (dBA).
4. All sound data listed by octave bands are raw data without any corrections for room absorption or duct attenuation.
5. Data derived from independent tests conducted in accordance with latest version of AHRI Standard 350.

Model Series 39VH, 39L & 39MU • AHRI Standard Ratings

EPIC ECM Motor

Unit Size	Coil Row	Airflow (Dry Flow)		Cooling Capacity		Water		Power Input (Watts)
		CFM	l/s	QT (Btuh)	QS (Btuh)	Flow Rate (GPM)	WPD ft-wg	
6	3			16000	12000	3.6	7.4	280
	4	600	283	19000	13000	4.5	15.1	280
10	3	1000	472	28000	21000	5.9	12.5	510
	4			33000	22000	7.3	11.1	510
15	3	1500	708	38000	29000	8.5	7.4	790
	4			49000	34000	10.8	13.4	790

Performance Notes:

1. Based on 80°F DB and 67°F WB EAT, 45°F EWT 10° temperature rise, maximum fan speed. Motor type is ECM or PSC as noted and motor voltage is 115/1/60. Airflow under dry coil conditions. All models tested at 0.0" external static pressure.
2. Unit size 19 to 21 fall outside the scope of AHRI Standard 440 Certification Program (above 1500 CFM).

PSC Motor

Unit Size	Coil Row	Airflow (Dry Flow)		Cooling Capacity		Water		Power Input (Watts)
		CFM	l/s	QT (Btuh)	QS (Btuh)	Flow Rate (GPM)	WPD ft-wg	
3	3			12000	9000	2.7	4.2	180
	4	375	177	13000	9000	2.9	2.7	
5	3	550	260	16000	12000	3.5	6.9	230
	4			17000	12000	3.6	4.3	
6	3	700	330	18000	14000	4.0	8.9	290
	4	675	319	20000	14000	4.3	5.9	
8	3	900	425	26000	19000	5.5	11.1	350
	4	875	413	31000	21000	6.7	9.4	
10	3	1100	519	29000	21000	6.3	14	500
	4	1075	507	35000	24000	7.6	12	
12	3	1200	566	34000	25000	7.5	5.7	650
	4	1175	554	42000	28000	9.2	9.8	

Model Series 39VH, 39L & 39MU • Chilled Water Coil Performance Data Unit Sizes 3, 5 and 6

Data Based on 75°F DB 63°F WB Entering Air & 45°F Entering Water

3 Row (Total MBH)

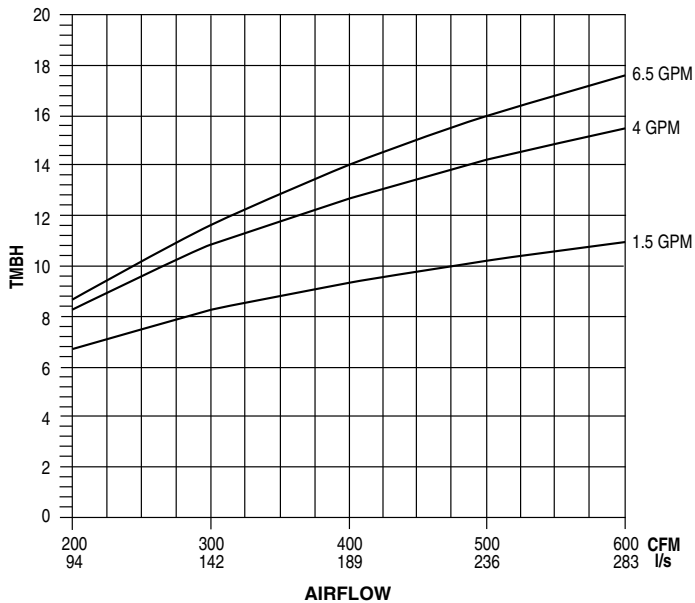

4 Row (Total MBH)

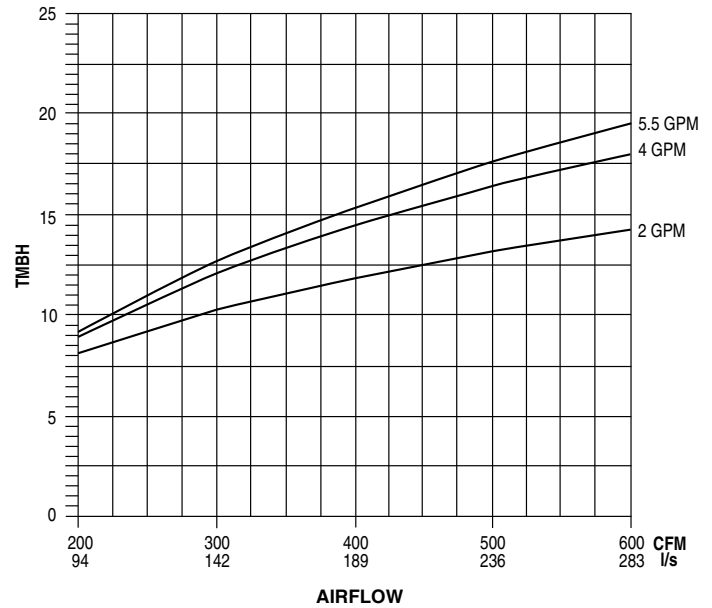

3 Row (Sensible MBH)

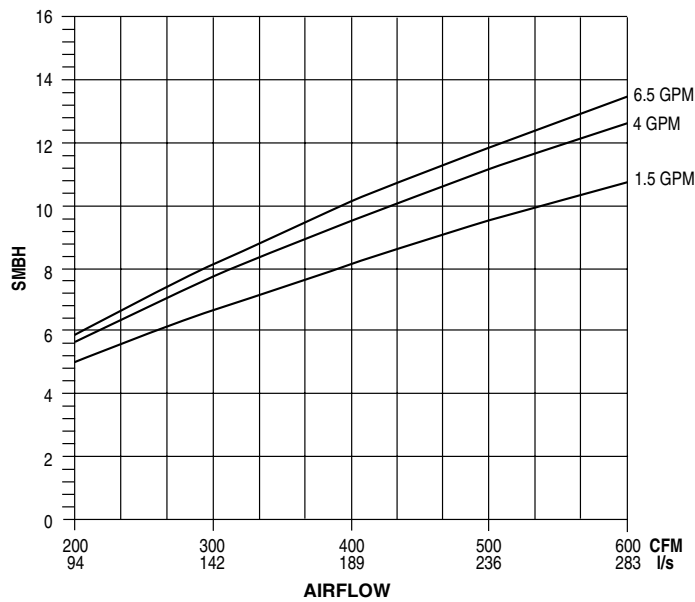

4 Row (Sensible MBH)

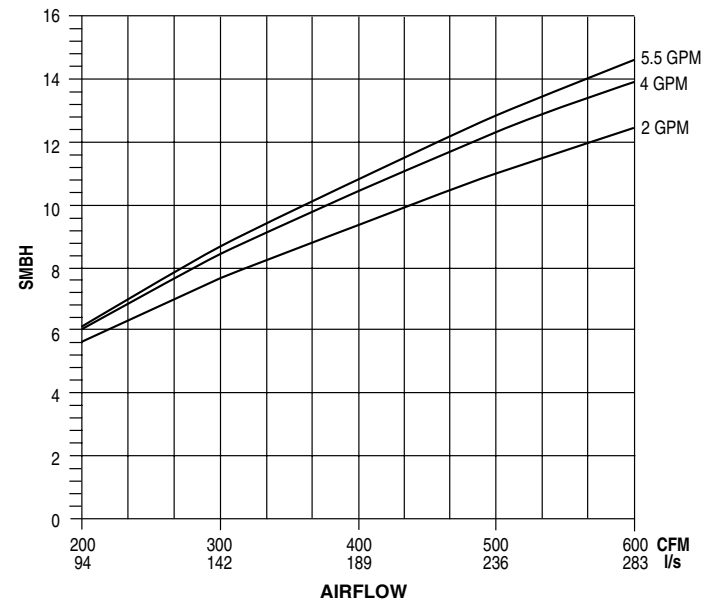

ALTITUDE CORRECTION FACTORS

Altitude (ft.)	0	1000	2000	3000	4000	5000	6000	7000
Air Density (lb./cu. ft)	0.075	0.072	0.070	0.067	0.065	0.063	0.060	0.058
Total Capacity	1000	0.988	0.986	0.983	0.981	0.979	0.977	0.975
Sensible Capacity	1000	0.960	0.930	0.900	0.860	0.830	0.800	0.770
Static Pressure	1000	0.960	0.930	0.900	0.860	0.830	0.800	0.770

NOTES:

- Capacity and static pressure will be affected for applications above sea level. To apply correction factors, multiply the coil capacity or fan curve data by the tabulated correction factor.
- Connections: 3 and 4 Row 5/8" (15.9) O.D. male solder.

Model Series 39VH, 39L & 39MU • Chilled Water Coil Performance Data Unit Sizes 3, 5 and 6

Data Based on 80°F DB 67°F WB Entering Air & 45°F Entering Water

3 Row (Total MBH)

4 Row (Total MBH)

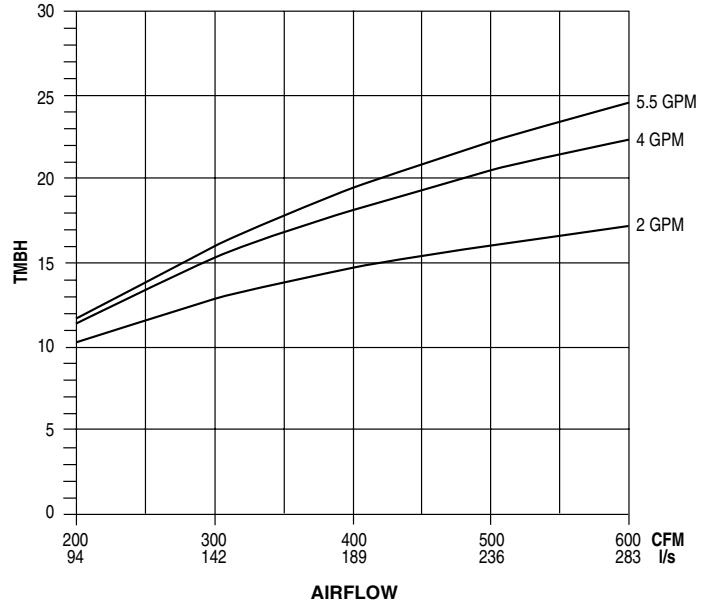
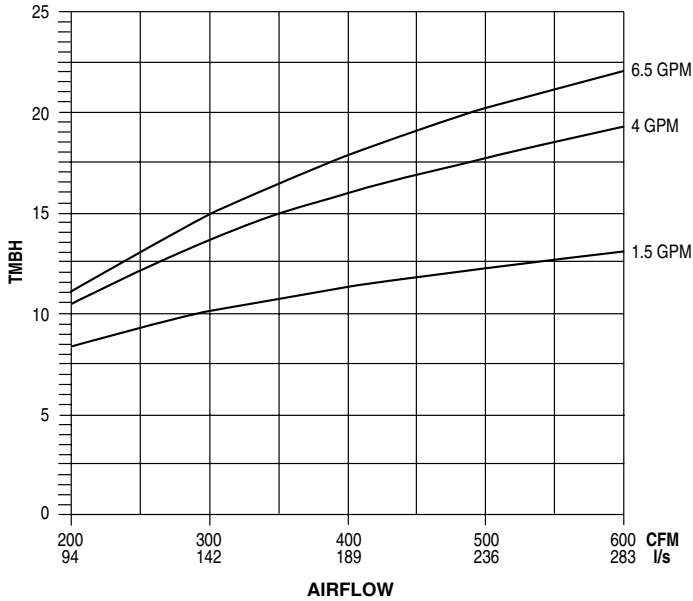

3 Row (Sensible MBH)

4 Row (Sensible MBH)

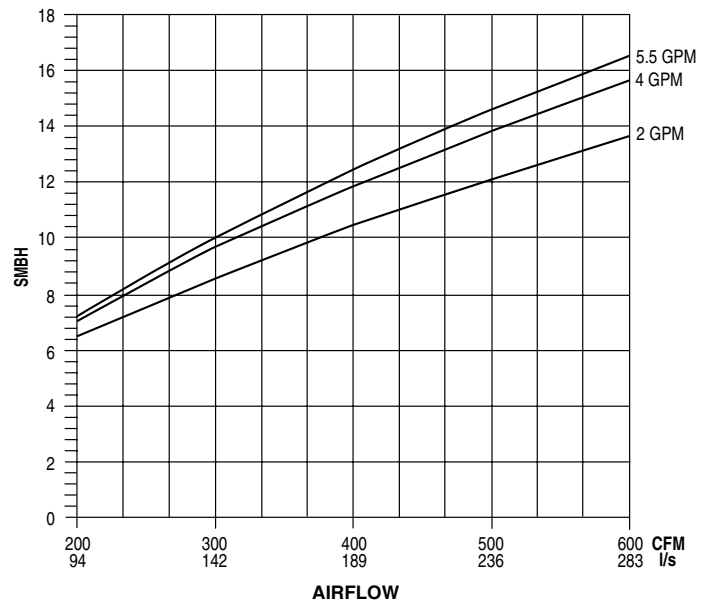
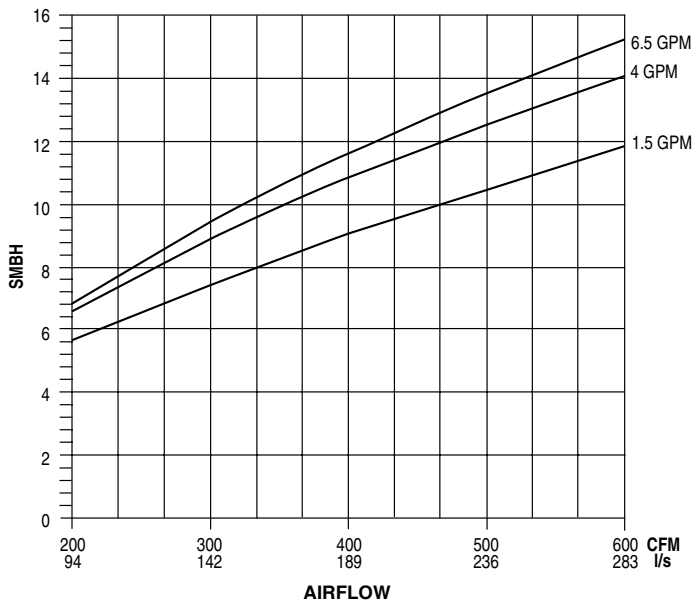

ALTITUDE CORRECTION FACTORS

Altitude (ft.)	0	1000	2000	3000	4000	5000	6000	7000
Air Density (lb./cu. ft)	0.075	0.072	0.070	0.067	0.065	0.063	0.060	0.058
Total Capacity	1000	0.988	0.986	0.983	0.981	0.979	0.977	0.975
Sensible Capacity	1000	0.960	0.930	0.900	0.860	0.830	0.800	0.770
Static Pressure	1000	0.960	0.930	0.900	0.860	0.830	0.800	0.770

NOTES:

- Capacity and static pressure will be affected for applications above sea level. To apply correction factors, multiply the coil capacity or fan curve data by the tabulated correction factor.
- Connections: 3 and 4 Row 5/8" (15.9) O.D. male solder.

A

VERTICAL HI-RISE/STACK FAN COIL UNITS

Model Series 39VH, 39L & 39MU • Chilled Water Coil Performance Data Unit Sizes 8 and 10

Data Based on 75°F DB 63°F WB Entering Air & 45°F Entering Water

3 Row (Total MBH)

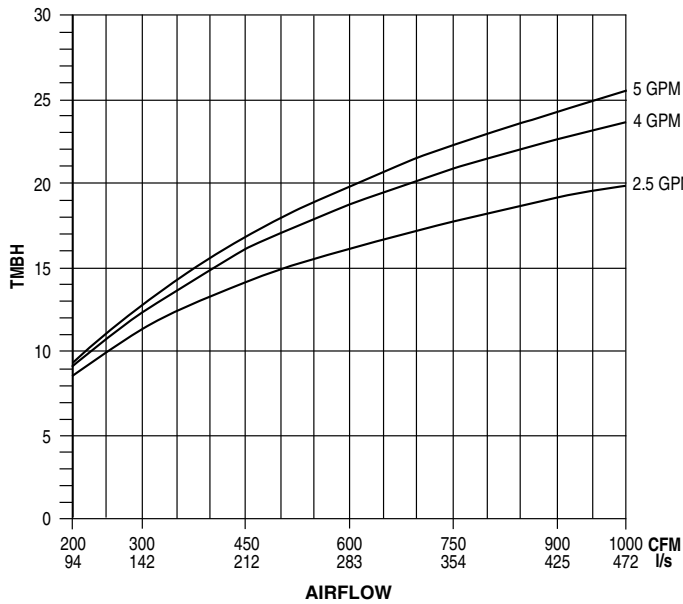

4 Row (Total MBH)

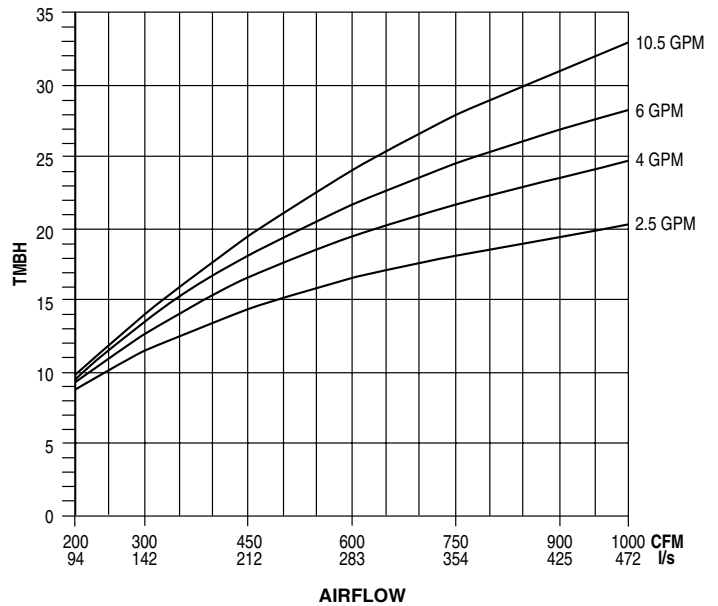

3 Row (Sensible MBH)

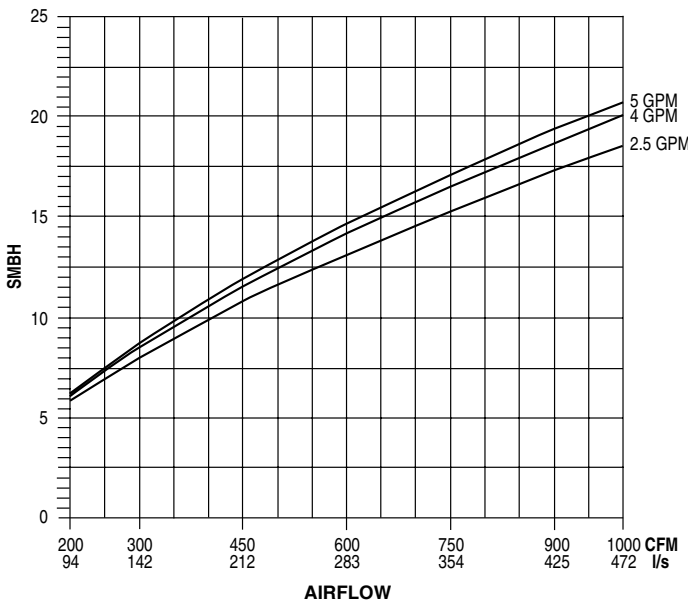

4 Row (Sensible MBH)

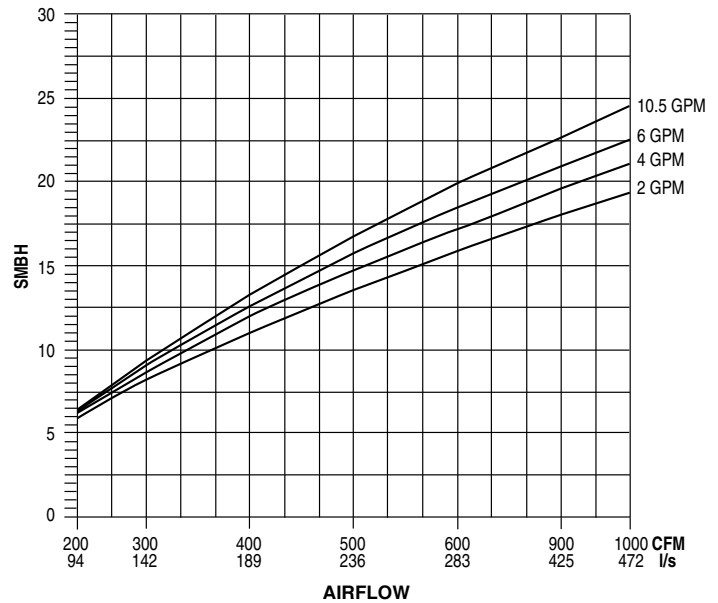

ALTITUDE CORRECTION FACTORS

Altitude (ft.)	0	1000	2000	3000	4000	5000	6000	7000
Air Density (lb./cu. ft)	0.075	0.072	0.070	0.067	0.065	0.063	0.060	0.058
Total Capacity	1000	0.988	0.986	0.983	0.981	0.979	0.977	0.975
Sensible Capacity	1000	0.960	0.930	0.900	0.860	0.830	0.800	0.770
Static Pressure	1000	0.960	0.930	0.900	0.860	0.830	0.800	0.770

NOTES:

- Capacity and static pressure will be affected for applications above sea level. To apply correction factors, multiply the coil capacity or fan curve data by the tabulated correction factor.
- Connections: 3 and 4 Row 5/8" (15.9) O.D. male solder.

Model Series 39VH, 39L & 39MU • Chilled Water Coil Performance Data Unit Sizes 8 and 10

Data Based on 80°F DB 67°F WB Entering Air & 45°F Entering Water

3 Row (Total MBH)

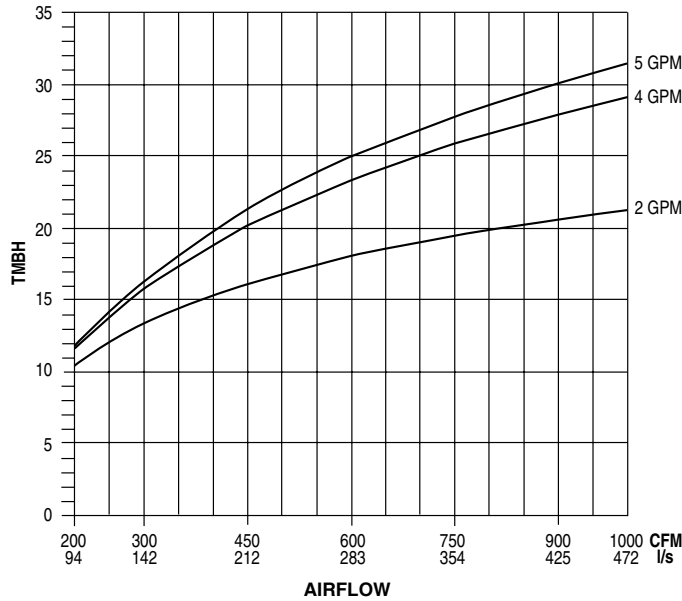

4 Row (Total MBH)

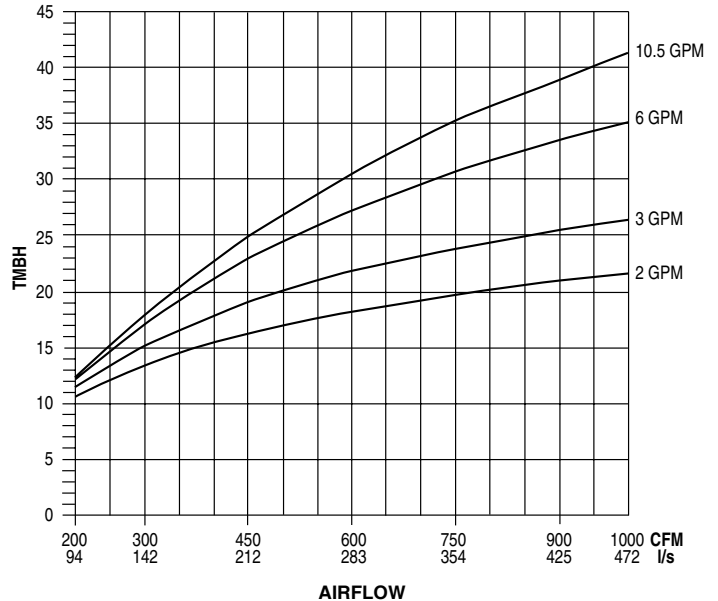

3 Row (Sensible MBH)

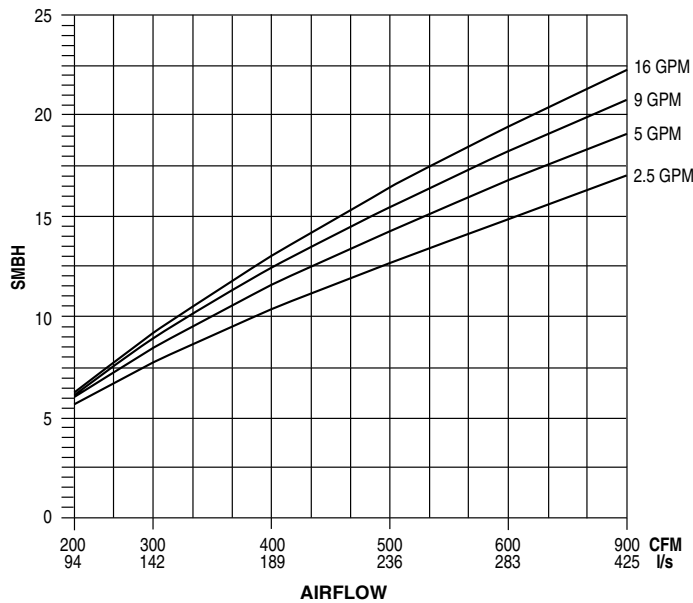

4 Row (Sensible MBH)

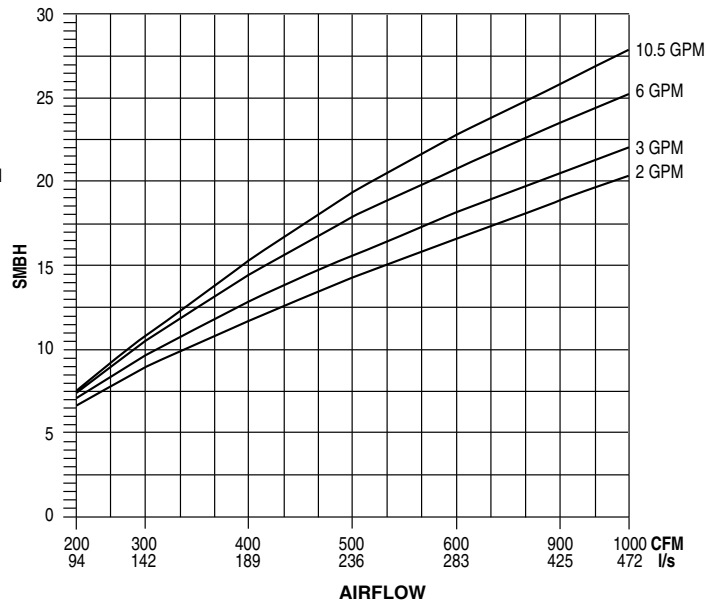

ALTITUDE CORRECTION FACTORS

Altitude (ft.)	0	1000	2000	3000	4000	5000	6000	7000
Air Density (lb./cu. ft)	0.075	0.072	0.070	0.067	0.065	0.063	0.060	0.058
Total Capacity	1000	0.988	0.986	0.983	0.981	0.979	0.977	0.975
Sensible Capacity	1000	0.960	0.930	0.900	0.860	0.830	0.800	0.770
Static Pressure	1000	0.960	0.930	0.900	0.860	0.830	0.800	0.770

NOTES:

- Capacity and static pressure will be affected for applications above sea level. To apply correction factors, multiply the coil capacity or fan curve data by the tabulated correction factor.
- Connections: 3 and 4 Row 5/8" (15.9) O.D. male solder.

A

VERTICAL HI-RISE/STACK FAN COIL UNITS

Model Series 39VH, 39L & 39MU • Chilled Water Coil Performance Data Unit Sizes 12 and 15

Data Based on 75°F DB 63°F WB Entering Air & 45°F Entering Water

3 Row (Total MBH)

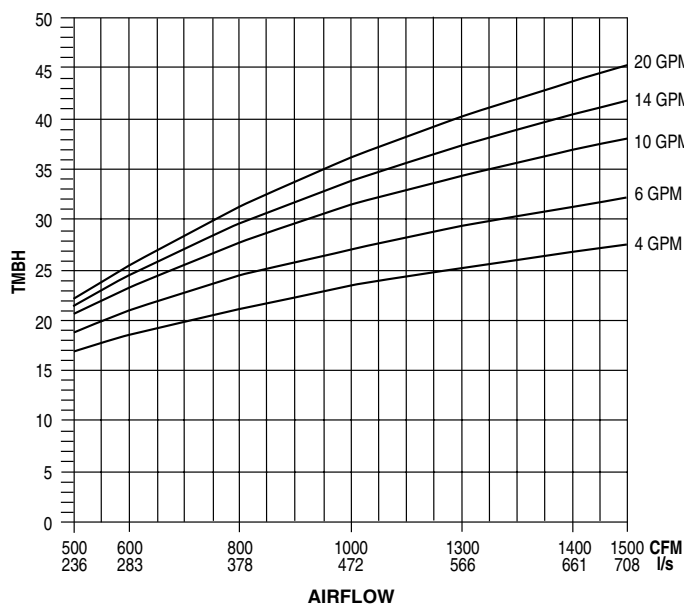

4 Row (Total MBH)

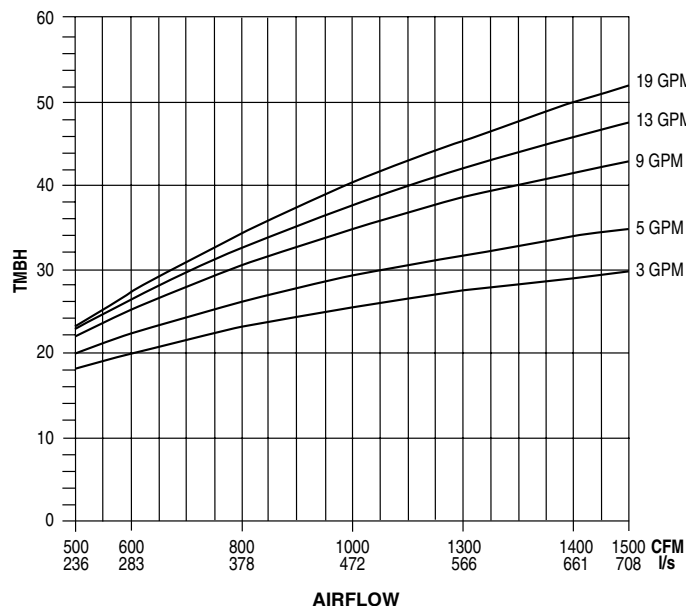

3 Row (Sensible MBH)

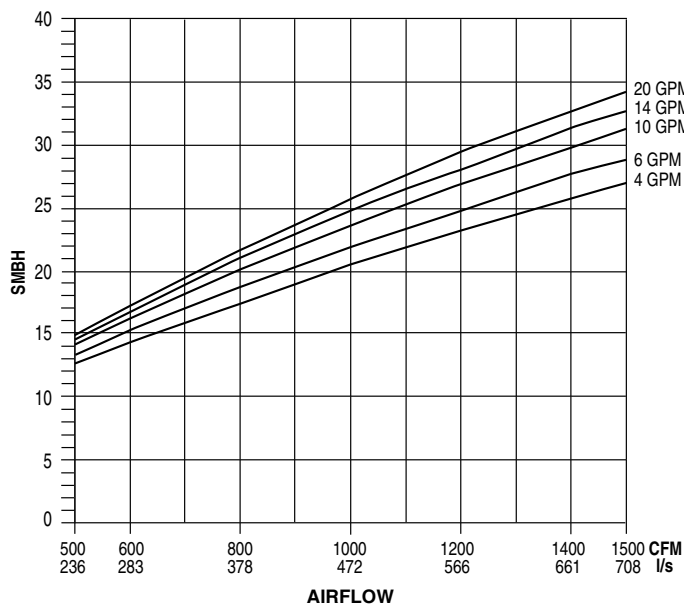

4 Row (Sensible MBH)

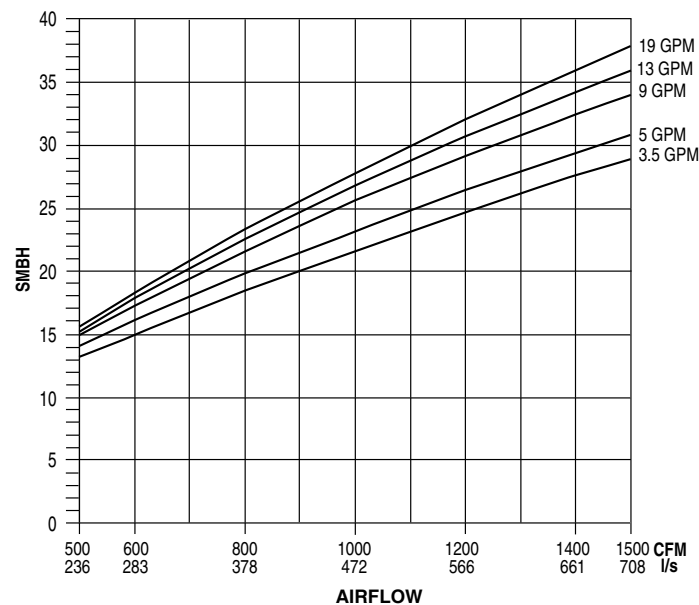

ALTITUDE CORRECTION FACTORS

Altitude (ft.)	0	1000	2000	3000	4000	5000	6000	7000
Air Density (lb./cu. ft)	0.075	0.072	0.070	0.067	0.065	0.063	0.060	0.058
Total Capacity	1000	0.988	0.986	0.983	0.981	0.979	0.977	0.975
Sensible Capacity	1000	0.960	0.930	0.900	0.860	0.830	0.800	0.770
Static Pressure	1000	0.960	0.930	0.900	0.860	0.830	0.800	0.770

NOTES:

- Capacity and static pressure will be affected for applications above sea level. To apply correction factors, multiply the coil capacity or fan curve data by the tabulated correction factor.
- Connections: 3 and 4 Row 7/8" (22.2) O.D. male solder.

A

VERTICAL HI-RISE/STACK FAN COIL UNITS

Model Series 39VH, 39L & 39MU • Chilled Water Coil Performance Data Unit Sizes 12 and 15

Data Based on 80°F DB 67°F WB Entering Air & 45°F Entering Water

3 Row (Total MBH)

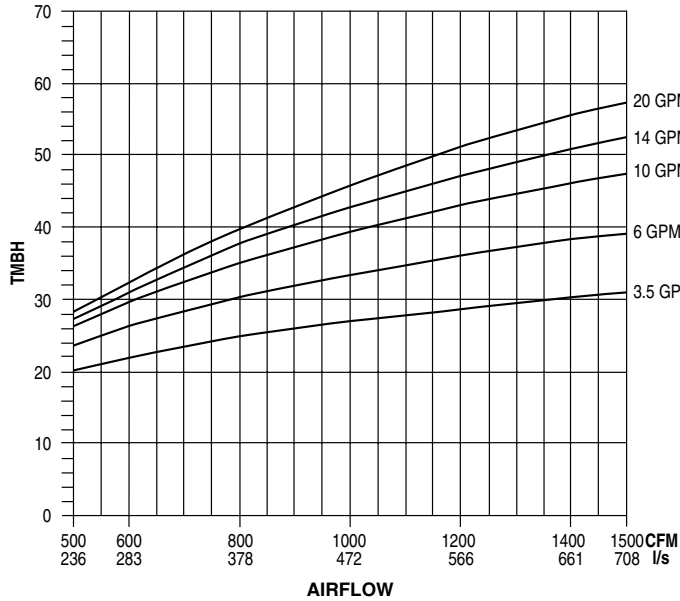

4 Row (Total MBH)

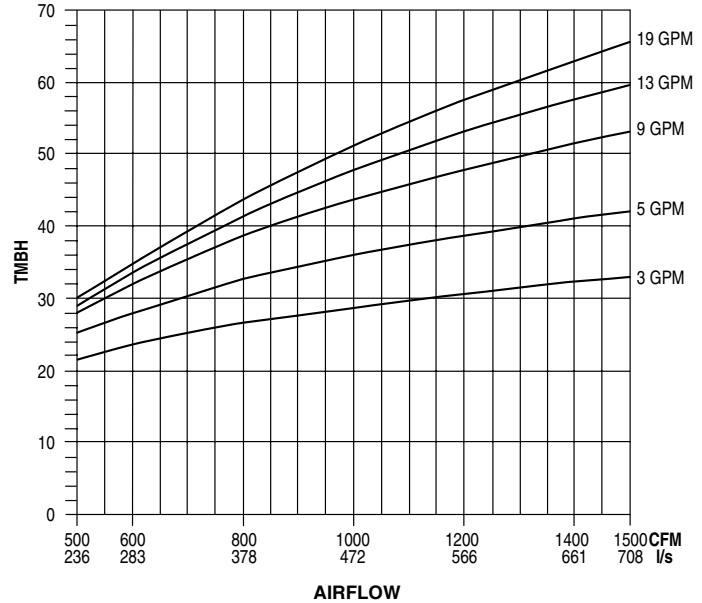

3 Row (Sensible MBH)

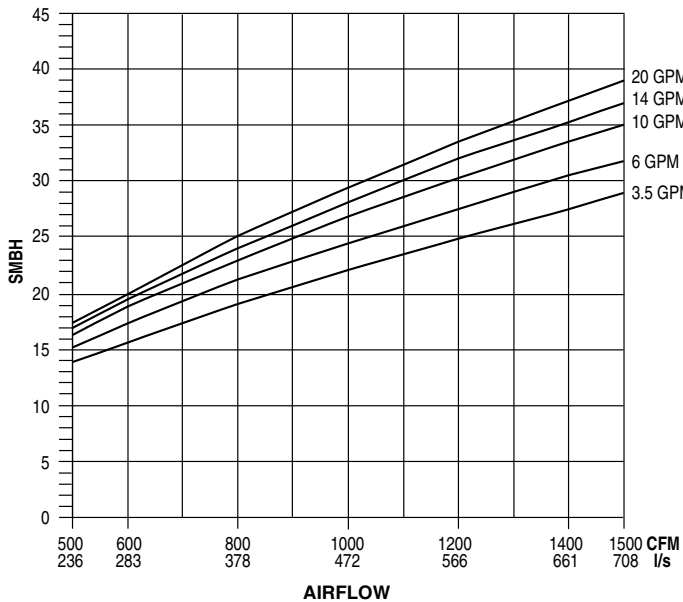

4 Row (Sensible MBH)

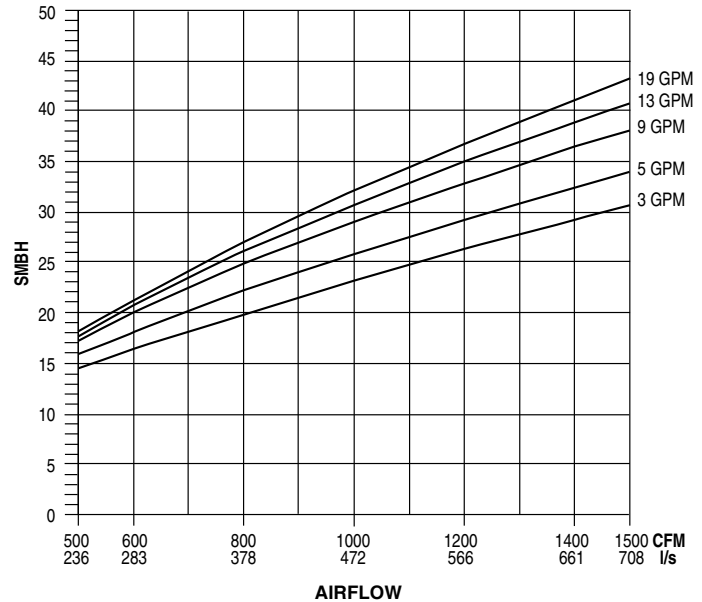

ALTITUDE CORRECTION FACTORS

Altitude (ft.)	0	1000	2000	3000	4000	5000	6000	7000
Air Density (lb./cu. ft)	0.075	0.072	0.070	0.067	0.065	0.063	0.060	0.058
Total Capacity	1000	0.988	0.986	0.983	0.981	0.979	0.977	0.975
Sensible Capacity	1000	0.960	0.930	0.900	0.860	0.830	0.800	0.770
Static Pressure	1000	0.960	0.930	0.900	0.860	0.830	0.800	0.770

NOTES:

- Capacity and static pressure will be affected for applications above sea level. To apply correction factors, multiply the coil capacity or fan curve data by the tabulated correction factor.
- Connections: 3 and 4 Row 7/8" (22.2) O.D. male solder.

A

VERTICAL HI-RISE/STACK FAN COIL UNITS

Model Series 39VH, 39L & 39MU • Chilled Water Coil Performance Data Unit Sizes 19 and 21

Data Based on 75°F DB 63°F WB Entering Air & 45°F Entering Water

3 Row (Total MBH)

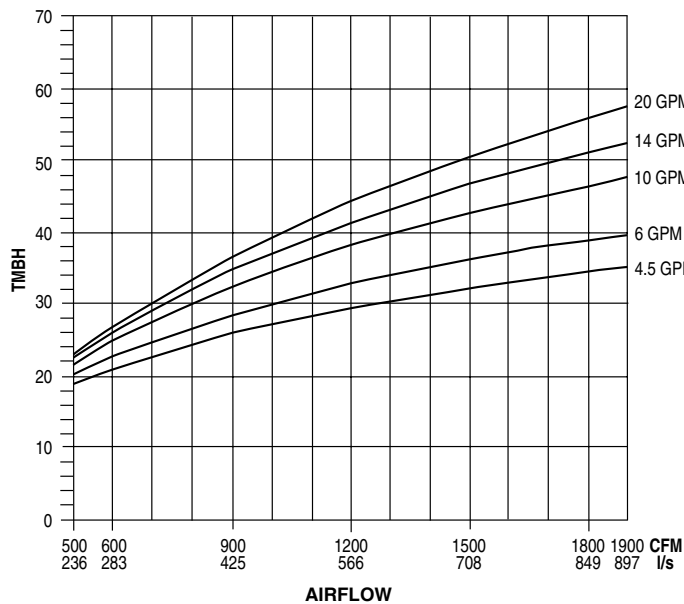

4 Row (Total MBH)

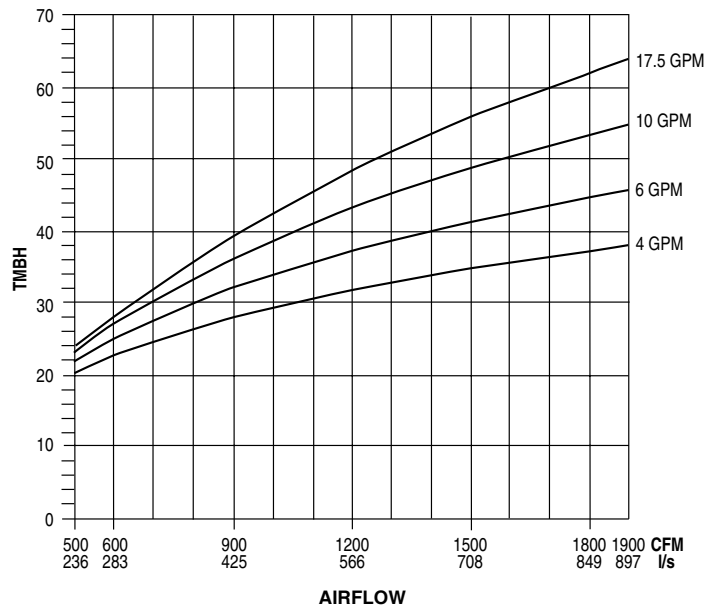

3 Row (Sensible MBH)

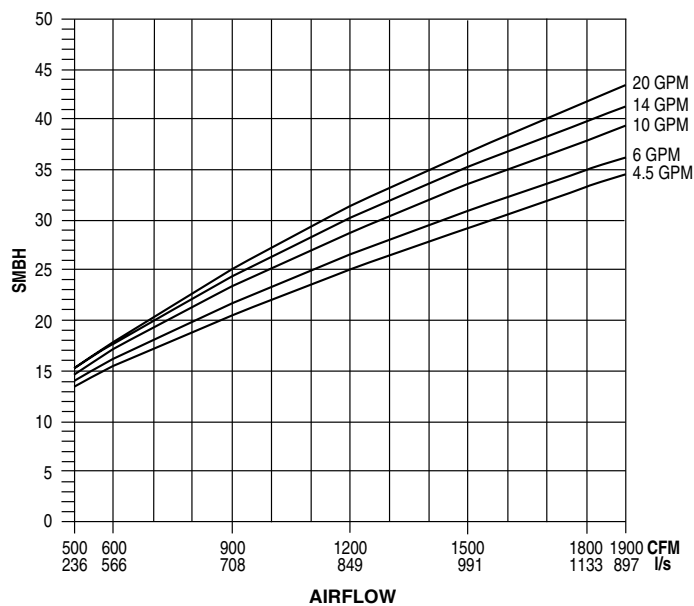

4 Row (Sensible MBH)

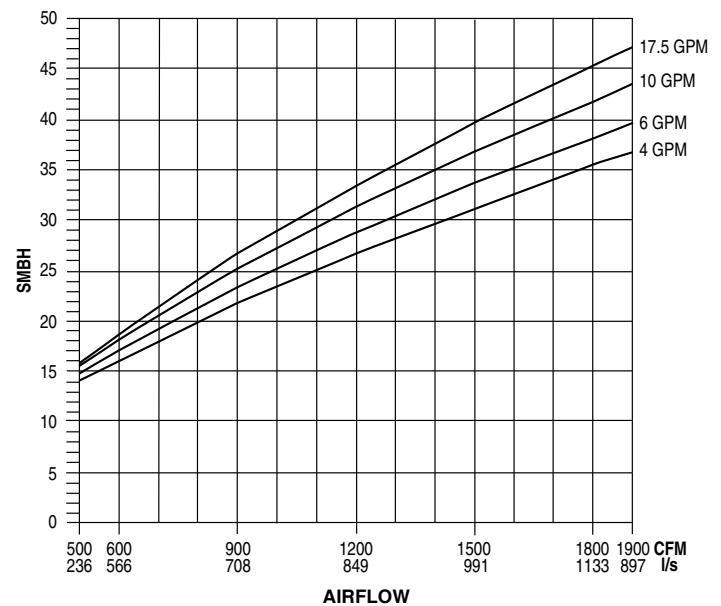

ALTITUDE CORRECTION FACTORS

Altitude (ft.)	0	1000	2000	3000	4000	5000	6000	7000
Air Density (lb./cu. ft)	0.075	0.072	0.070	0.067	0.065	0.063	0.060	0.058
Total Capacity	1000	0.988	0.986	0.983	0.981	0.979	0.977	0.975
Sensible Capacity	1000	0.960	0.930	0.900	0.860	0.830	0.800	0.770
Static Pressure	1000	0.960	0.930	0.900	0.860	0.830	0.800	0.770

NOTES:

- Capacity and static pressure will be affected for applications above sea level. To apply correction factors, multiply the coil capacity or fan curve data by the tabulated correction factor.
- Connections: 3 and 4 Row 7/8" (22.2) O.D. male solder.

Model Series 39VH, 39L & 39MU • Chilled Water Coil Performance Data Unit Sizes 19 and 21

Data Based on 80°F DB 67°F WB Entering Air & 45°F Entering Water

3 Row (Total MBH)

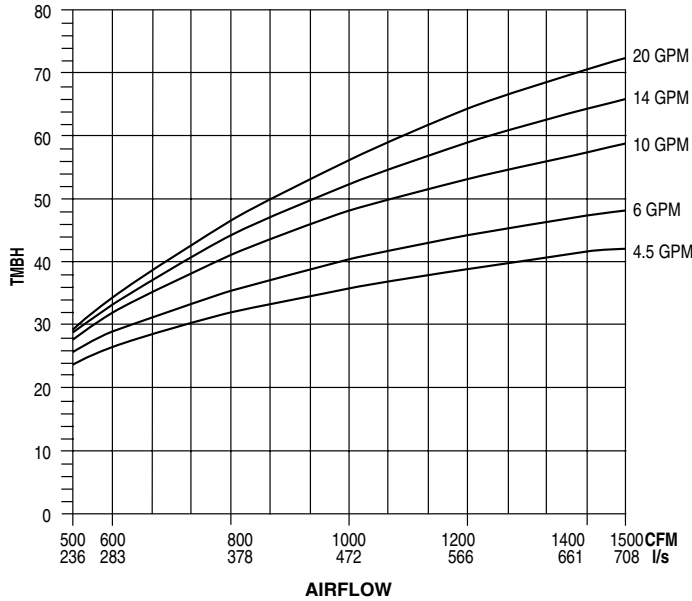

4 Row (Total MBH)

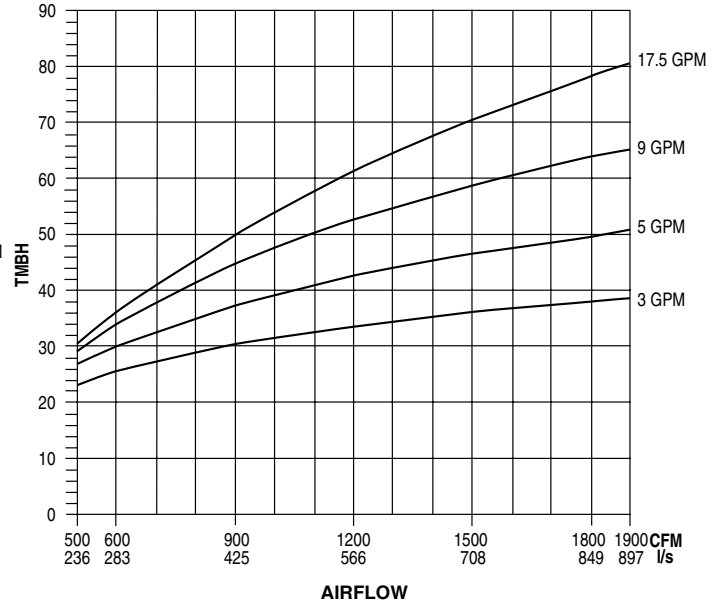

3 Row (Sensible MBH)

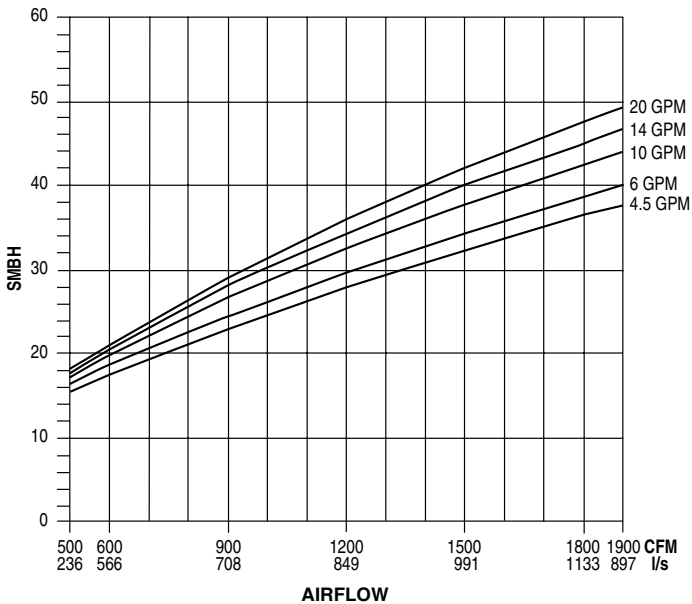

4 Row (Sensible MBH)

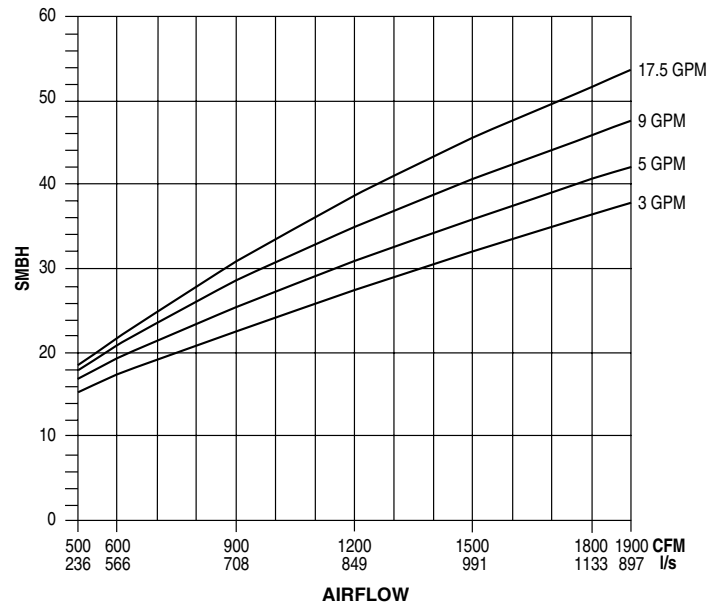

ALTITUDE CORRECTION FACTORS

Altitude (ft.)	0	1000	2000	3000	4000	5000	6000	7000
Air Density (lb./cu. ft)	0.075	0.072	0.070	0.067	0.065	0.063	0.060	0.058
Total Capacity	1000	0.988	0.986	0.983	0.981	0.979	0.977	0.975
Sensible Capacity	1000	0.960	0.930	0.900	0.860	0.830	0.800	0.770
Static Pressure	1000	0.960	0.930	0.900	0.860	0.830	0.800	0.770

NOTES:

- Capacity and static pressure will be affected for applications above sea level. To apply correction factors, multiply the coil capacity or fan curve data by the tabulated correction factor.
- Connections: 3 and 4 Row 7/8" (22.2) O.D. male solder.

A

VERTICAL HI-RISE/STACK FAN COIL UNITS

Model Series 39VH, 39L & 39MU • Hot Water Coil Performance Data Unit Sizes 3, 5 and 6

Data Based on 70°F DB Entering Air & 180°F Entering Water

1 Row (Total MBH)

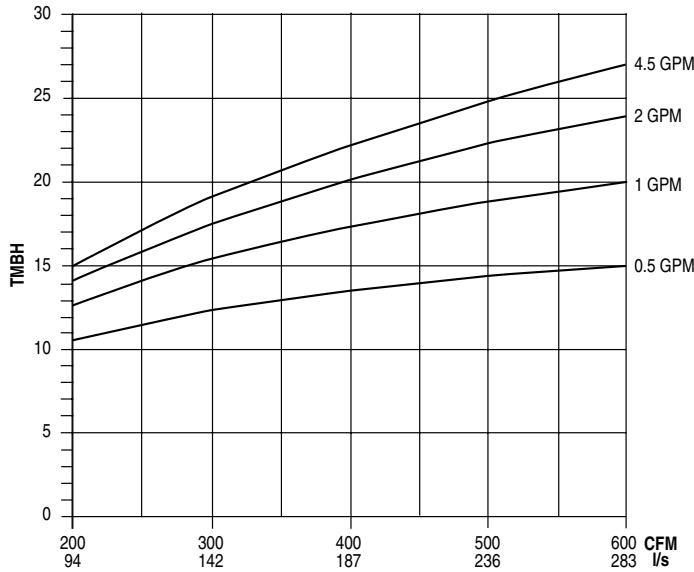

2 Row (Total MBH)

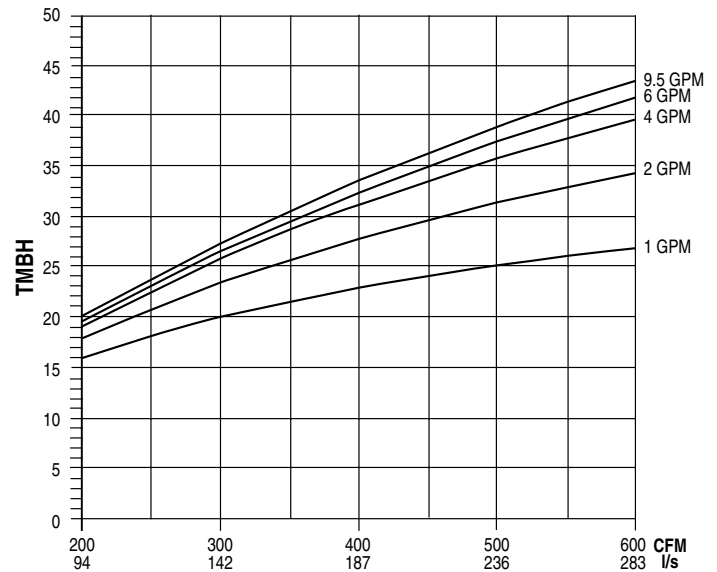

Unit Sizes 8 and 10

1 Row (Total MBH)

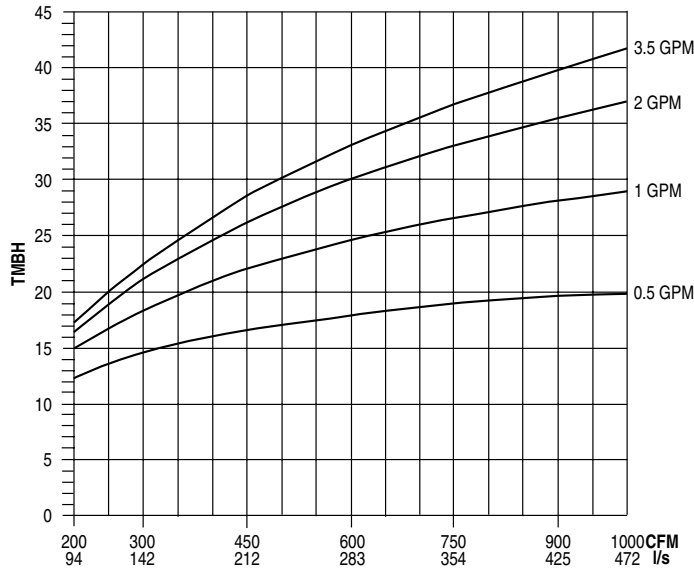

2 Row (Total MBH)

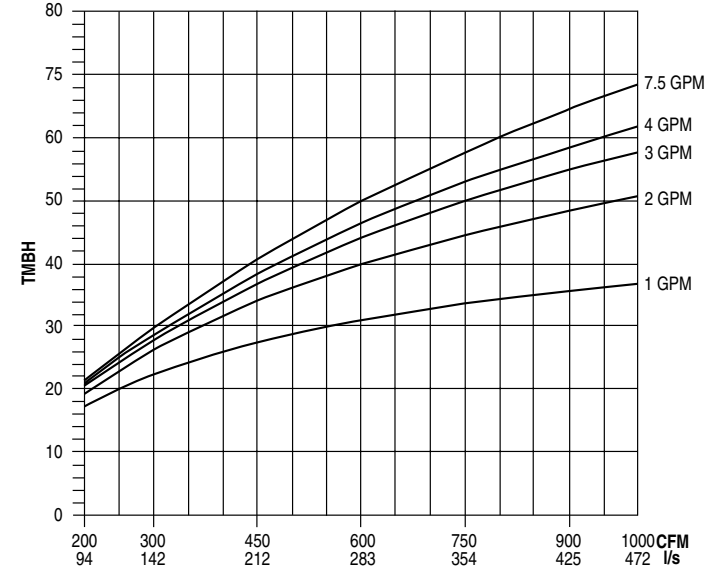

NOTES:

- Capacities are in MBH (kW), *thousands of Btu per hour (kiloWatts)*.
- MBH (kW) values are based on a Δt (temperature difference) of 110°F (61°C) between entering air and entering water. For other Δt 's; multiply the MBH (kW) values by the factors below.

- Air Temperature Rise.

$$\text{ATR (}^\circ\text{F)} = 927 \times \frac{\text{MBH}}{\text{CFM}}, \text{ ATR (}^\circ\text{C)} = 829 \times \frac{\text{kW}}{\text{l/s}}$$

- Water Temp. Drop.

$$\text{WTD (}^\circ\text{F)} = 2.04 \times \frac{\text{MBH}}{\text{GPM}}, \text{ WTD (}^\circ\text{C)} = .224 \times \frac{\text{kW}}{\text{l/s}}$$

- Connections: One and two row 5/8" (15.9) O.D. male solder.

Altitude Correction Factors:

Altitude ft. (m)	Sensible Heat Factor
0 (0)	1.00
2000 (610)	0.94
3000 (914)	0.90
4000 (1219)	0.87
5000 (1524)	0.84
6000 (1829)	0.81
7000 (2134)	0.78

Correction factors at other entering conditions:

Δt °F (°C)	50 (28)	60 (33)	70 (39)	80 (44)	90 (50)	100 (56)	110 (61)	120 (67)	130 (72)	140 (78)	150 (83)
Factor	.455 (.459)	.545 (.541)	.636 (.639)	.727 (.721)	.818 (.820)	.909 (.918)	1.00 (1.00)	1.09 (1.10)	1.18 (1.18)	1.27 (1.28)	1.36 (1.36)

Model Series 39VH, 39L & 39MU • Hot Water Coil Performance Data Unit Sizes 12 and 15

Data Based on 70°F DB Entering Air & 180°F Entering Water

1 Row (Total MBH)

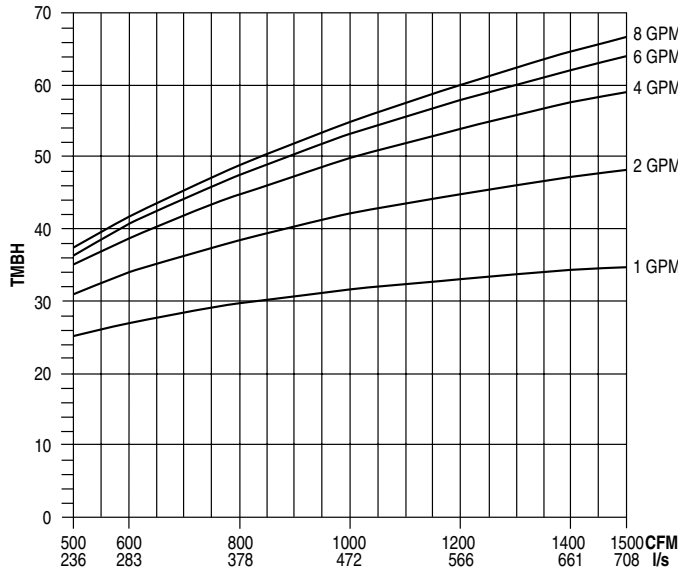

2 Row (Total MBH)

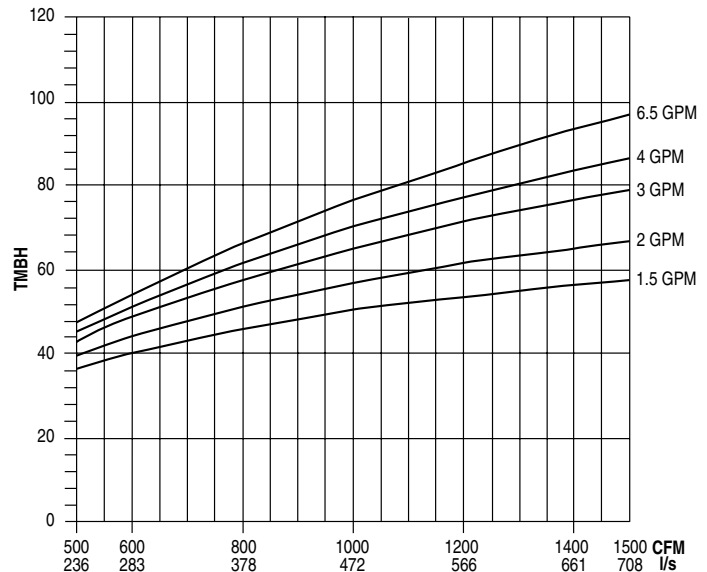

Unit Sizes 19 and 21

1 Row (Total MBH)

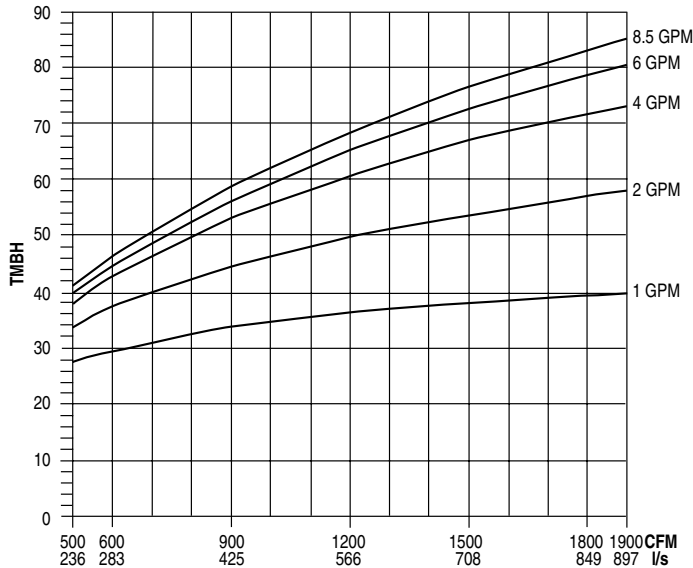

2 Row (Total MBH)

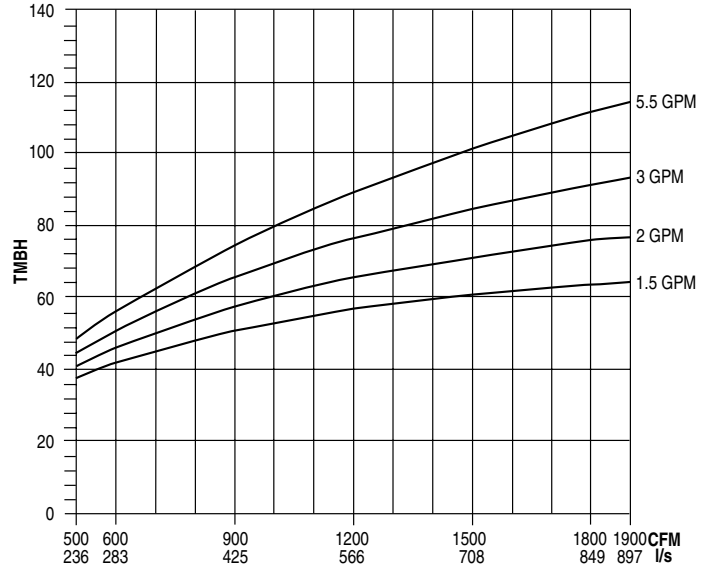

NOTES:

- Capacities are in MBH (kW), **thousands of Btu per hour (kiloWatts)**.
- MBH (kW) values are based on a Δt (temperature difference) of 110°F (61°C) between entering air and entering water. For other Δt 's; multiply the MBH (kW) values by the factors below.

- Air Temperature Rise.

$$ATR (^\circ F) = 927 \times \frac{MBH}{CFM}, \quad ATR (^\circ C) = 829 \times \frac{kW}{I/s}$$

- Water Temp. Drop.

$$WTD (^\circ F) = 2.04 \times \frac{MBH}{GPM}, \quad WTD (^\circ C) = .224 \times \frac{kW}{I/s}$$

- Connections: One and two row 5/8" (15.9) O.D. male solder.

Altitude Correction Factors:

Altitude ft. (m)	Sensible Heat Factor
0 (0)	1.00
2000 (610)	0.94
3000 (914)	0.90
4000 (1219)	0.87
5000 (1524)	0.84
6000 (1829)	0.81
7000 (2134)	0.78

Correction factors at other entering conditions:

Δt °F (°C)	50 (28)	60 (33)	70 (39)	80 (44)	90 (50)	100 (56)	110 (61)	120 (67)	130 (72)	140 (78)	150 (83)
Factor	.455 (.459)	.545 (.541)	.636 (.639)	.727 (.721)	.818 (.820)	.909 (.918)	1.00 (1.00)	1.09 (1.10)	1.18 (1.18)	1.27 (1.28)	1.36 (1.36)

A

VERTICAL HI-RISE/STACK FAN COIL UNITS

Model Series 39VH, 39L & 39MU • Coil Performance Data • Pressure Drop Unit Sizes 3, 5 and 6

Chilled Water Pressure Drop

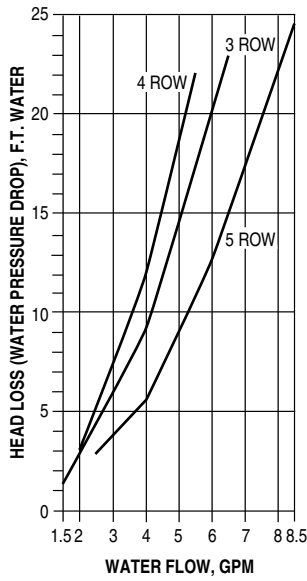

Hot Water Pressure Drop

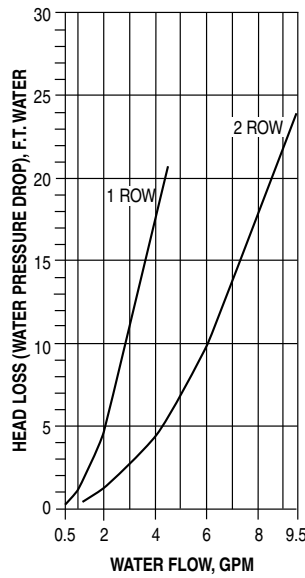

Chilled and Hot Water Air Pressure Drop

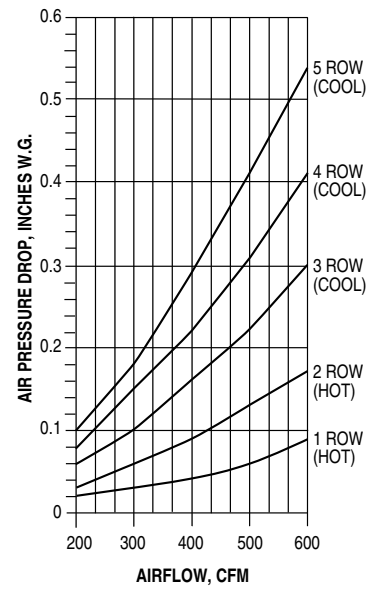

Unit Sizes 8 and 10

Chilled Water Pressure Drop

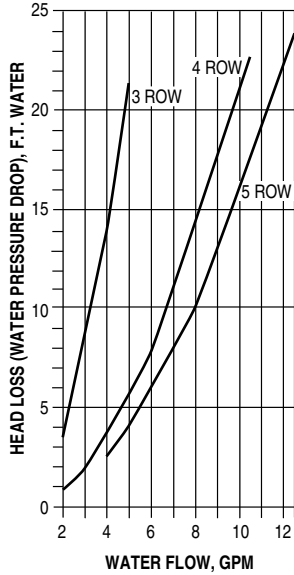

Hot Water Pressure Drop

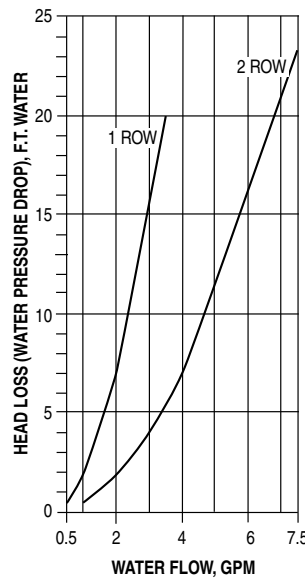

Chilled and Hot Water Air Pressure Drop

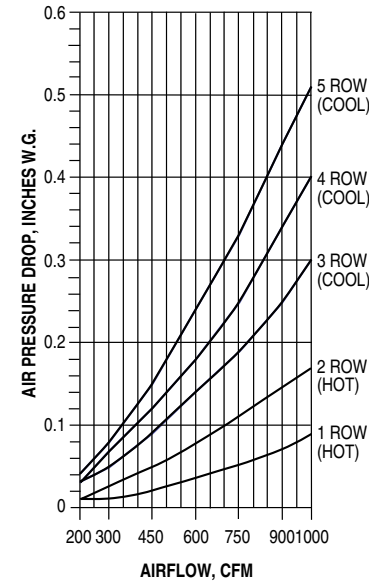

METRIC CONVERSION FACTORS:

1. Water Flow (liters per second)
 $l/s = \text{gpm} \times 0.6309$
2. Water Head Loss (kilopascals):
 $\text{kPa} = \text{ft. w.g.} \times 2.9837$
3. Airflow Volume (liters per second)
 $l/s = \text{CFM} \times 0.472$

4. Air Pressure Drop (Pascals):
 $\text{Pa} = \text{in. w.g.} \times 248.6$
5. Heat (kilowatts):
 $\text{kW} = \text{Mbh} \times 0.293$
6. Air Temperature Rise.
 $\text{ATR} = 927 \times \frac{\text{Mbh}}{\text{CFM}}$

7. Water Temp. Drop.
 $\text{WTD} = 2.04 \times \frac{\text{Mbh}}{\text{GPM}}$

A
VERTICAL HI-RISE/STACK FAN COIL UNITS

Model Series 39VH, 39L & 39MU • Coil Performance Data • Pressure Drop Unit Sizes 12 and 15

Chilled Water Pressure Drop

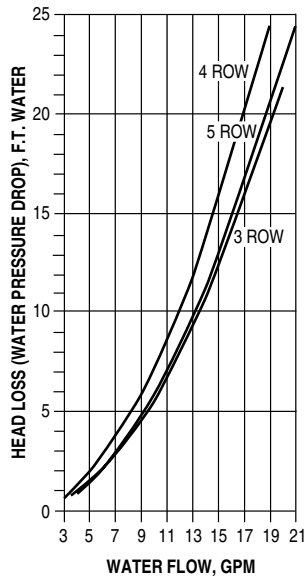

Hot Water Pressure Drop

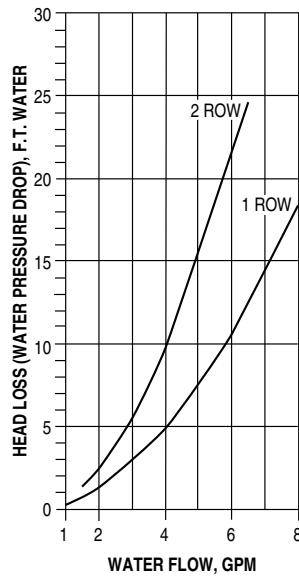

Chilled and Hot Water Air Pressure Drop

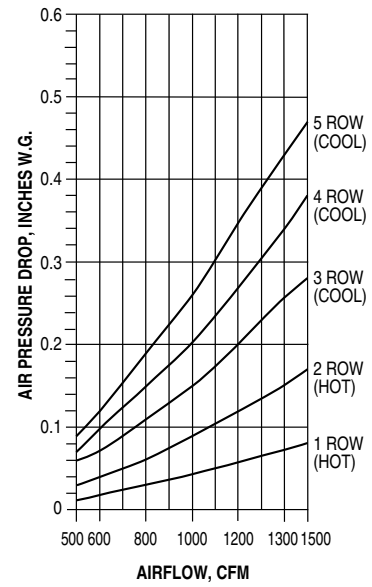

Unit Sizes 19 and 21

Chilled Water Pressure Drop

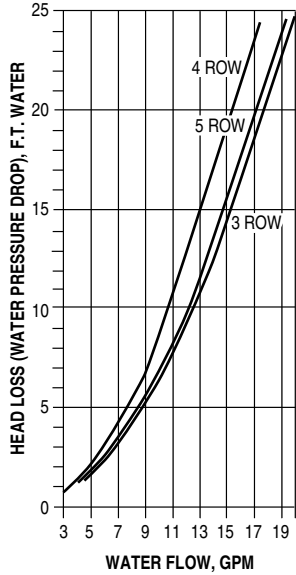

Hot Water Pressure Drop

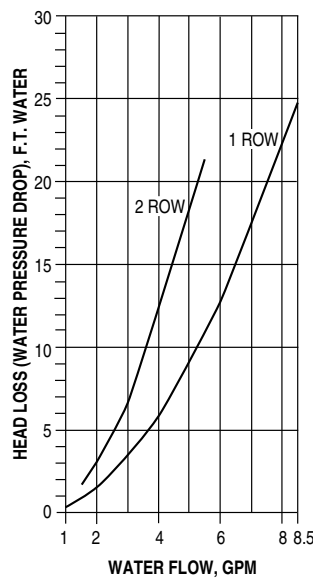

Chilled and Hot Water Air Pressure Drop

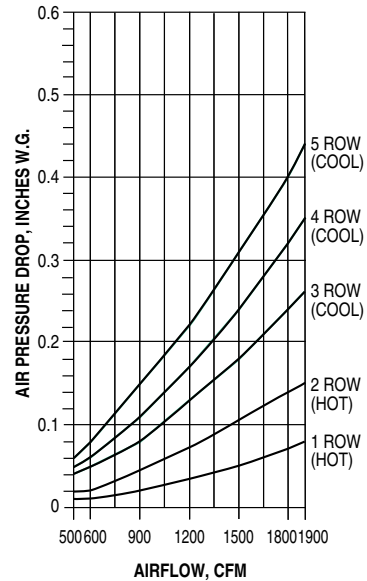

METRIC CONVERSION FACTORS:

- Water Flow (liters per second)
 $l/s = gpm \times 0.6309$
- Water Head Loss (kilopascals):
 $kPa = ft. w.g. \times 2.9837$
- Airflow Volume (liters per second)
 $l/s = CFM \times 0.472$
- Air Pressure Drop (Pascals):
 $Pa = in. w.g. \times 248.6$
- Heat (kilowatts):
 $kW = Mbh \times 0.293$
- Air Temperature Rise.
 $ATR = 927 \times \frac{Mbh}{CFM}$
- Water Temp. Drop.
 $WTD = 2.04 \times \frac{Mbh}{GPM}$

A

VERTICAL HI-RISE/STACK FAN COIL UNITS

Model Series 39VH, 39L & 39MU • Suggested Specifications

1. General

Furnish and install Engineered Comfort Vertical Hi-Rise Direct Drive Fan Coil Units where indicated on the plans and in the specifications. Units shall be completely factory assembled, tested, and shipped as one piece. All units shall be capable of meeting or exceeding the scheduled capacities for cooling, heating, and air delivery. All unit dimensions for each model and size shall be considered maximums. Units shall be ETL listed in compliance with UL/ANSI Standard 1995, and be certified as complying with the latest edition of AHRI Standard 440.

2. Construction

a. All unit chassis shall be fabricated of heavy gauge galvanized steel panels able to meet 125-hour salt spray test per ASTM B-117. All exterior panels shall be insulated with 1/2" (13) thick insulation with a maximum k value of .24 (Btu • in) / (hr • ft² • °F) and rated for a maximum air velocity of 6000 fpm. Insulation must meet all requirements of ASTM C 1071 (including ASTM C 665), UL 181 for erosion, and carry a 25/50 rating for flame spread/smoke developed per ASTM E-84, UL 723, NFPA 90A, and NFPA 255.

Optional

- For units with multiple outlets, include an insulated sheet metal baffle inside the discharge plenum to break the sight lines between the two discharge outlets and to attenuate room noise that could be transmitted through the openings.
 - All units shall have decorator front panels fabricated of not less than 18 gauge (1.31) galvanized steel. The front panel shall include a commercial grade return air grille and be attached with quarter turn quick open fasteners to allow for easy removal and access for service.
 - All exposed units shall have exterior panels fabricated of not less than 18 gauge (1.31) galvanized steel. The front panel shall be attached with quarter turn quick open fasteners to allow for easy removal and access for service.
- b. Provide an architectural grade double deflection aluminum discharge grille.

Optional

- Provide foil faced insulation in lieu of standard. Foil insulation shall meet or exceed the requirements stated above, and in addition meet ASTM Standards C-665 and C-1136 for biological growth in insulation. Insulation shall be lined with aluminum foil, fiberglass scrim reinforcement, and 30 pound Kraft paper laminated together with a flame-resistant adhesive. All exposed edges shall be sealed to prevent any fibers from reaching the air stream.
- Provide Elastomeric Closed Cell Foam Insulation in lieu of standard. Insulation shall conform to UL 181 for erosion and NFPA 90A for fire, smoke and melting, and comply with a 25/50 Flame Spread and Smoke Developed Index per ASTM E-84 or UL 723. Additionally, insulation shall comply with Antimicrobial Performance Rating of 0, no observed growth, per ASTM G-21. Polyethylene insulation is not acceptable.

3. Painted Finish

All painted cabinet exterior panels shall be finished with a TGIC Polyester powder paint of the standard factory color.

4. Sound

Units shall have published sound power performance level data derived from independent tests conducted in accordance with latest version of AHRI Standard 350.

5. Fan Assembly

a. Unit fan shall be dynamically balanced, forward curved, DWDI centrifugal type constructed of 18 ga. (1.31) galvanized steel for corrosion resistance. Motors shall be high efficiency, permanently lubricated sleeve bearing, permanent split-capacitor type with UL and CSA listed automatic reset thermal overload protection and three separate horsepower taps. Single speed motors are not acceptable.

b. Provide a blower panel to cover the entire fan assembly. The blower panel shall be tight fitting to prevent air bypass and prohibit accidental contact with the fan assembly. Units that allow accidental contact with the fan assembly with the decorator front panel removed are not acceptable.

c. The fan assembly shall be removed and serviced through the front and safety panels. The entire assembly shall be able to come out of the unit easily by removing four screws and unplugging the motor.

6. Coils

a. All cooling and heating coils shall optimize rows and fins per inch to meet the specified capacity. Coils shall have seamless copper tubes and shall be mechanically expanded to provide an efficient, permanent bond between the tube and fin. Fins shall have high efficiency aluminum surface optimized for heat transfer, air pressure drop and carryover.

b. All coils shall be tested at 360 PSIG air pressure, and rated for a maximum 300 PSIG working pressure at 200°F (93°C). All coils are pressure tested with a minimum 360 PSIG of dry air with higher test pressures performed as required.

c. Heating coils shall be furnished in the reheat position as standard.

d. All water coils shall be provided with a manual air vent fitting to allow for coil venting.

Optional

- Provide automatic air vents in lieu of manual air vents.
- Coil casing shall be fabricated from stainless steel.

7. Drain Pans

a. Primary condensate drain pans shall be single wall, heavy gauge galvanized steel for corrosion resistance, and extend under the entire coil section. Drain pans shall be of one-piece construction and be positively sloped for condensate removal. A P-Trap shall be furnished, factory piped to the condensate drain riser.

b. The drain pan shall be externally insulated with fire retardant, closed cell foam insulation. The insulation shall carry no more than a 25/50 Flame Spread and Smoke Developed Rating per ASTM E-84 and UL 723 and an Antimicrobial Performance Rating of 0, no observed growth, per ASTM G-21. The P-Trap shall be easily removed and serviced through the front panel.

Optional

- Provide a primary drain pan constructed entirely of heavy gauge type stainless steel for superior corrosion resistance. Stainless steel drain pans shall be externally insulated and meet or exceed the requirements stated above.

8. Filters

All units shall be furnished with a minimum 1" (25) nominal glass fiber throwaway filter. Filters shall be tight fitting to prevent air bypass. Filters shall be easily removable from the return air opening with the front panel removed, without the need for tools.

Optional

- Provide unit with 1" (25) MERV 8 pleated filter.

9. Electrical

Units shall be furnished with single point power connection. Provide a terminal strip for motor and other electrical terminations. The factory mounted terminal wiring strip consists of a multiple position screw terminal block to facilitate wiring terminations for the electric control valves and thermostats.

10. Electric Heat

a. Furnish an electric resistance heating assembly as an integral part of the fan coil unit, with the heating capacity, voltage and kilowatts scheduled. The heater assembly shall be rated for installation on the fan coil unit and be located so as not to expose the fan assembly to excessive leaving air temperatures that could affect motor performance.

Model Series 39VH, 39L & 39MU • Suggested Specifications (continued)

- b. The heater and unit assembly shall be listed for zero clearance and meet all NEC requirements, and be ETL listed with the unit as an assembly in compliance with UL/ANSI Standard 1995.
- c. All heating elements shall be open coil type Ni-Chrome wire mounted in ceramic insulators and located in an insulated heavy gauge galvanized steel housing. All elements shall terminate in a machine staked stainless steel terminal secured with stainless steel hardware for corrosion resistance. The element support brackets shall be spaced no greater than 3-1/2" (89) on center. All internal wiring shall be rated for 221°F (105°C) minimum.
- d. All heaters shall include over temperature protection consisting of an automatic reset primary thermal limit.

Optional

- Provide a manual reset secondary thermal limit.
- e. All units with electric heat shall be provided with an incoming line power distribution block, designated to accept single point power wiring capable of carrying 125% of the calculated load current.

11. Piping Packages

- a. Provide a standard factory assembled valve piping package to consist of a 2 or 3-way, on/off, motorized electric control valve and two ball isolation valves. Control valves shall be piped normally closed to the coil. Maximum entering water temperature on the control valve shall be 200°F (93°C), and maximum close-off pressure 25 PSIG. Maximum operating pressure shall be 300 PSIG.
- b. Piping packages shall include stainless steel braided hoses to allow for thermal expansion within the unit cabinet. The hose shall be EPDM inner lined and Kevlar® reinforced, with stainless steel FNPT swivels and/or fittings. The hoses shall be rated for a maximum 450 PSIG working pressure at 250°F (121°C), and shall conform to NFPA 90A and carry no more than a 25/50 Flame Spread and Smoke Developed Rating, per ASTM E-84 and UL 723.

Optional

- Provide a 0-10 VDC modulating control valve (fail-in-place) in lieu of standard 2-position control valve with factory assembled valve piping package.
- Provide either a fixed or adjustable flow control device for each piping package.
- Provide pressure-temperature ports for each piping package.
- c. Piping packages shall be completely factory assembled, including interconnecting pipe, and mounted inside the unit in a serviceable location over the coil and primary drain pan.

12. Risers

- a. Furnish chilled and hot water supply and return risers mounted to the unit. Risers shall be Type-M seamless copper tube and include swaged connections at the top for connection to the unit above. Slip couplings are not acceptable.

Optional

- Provide Type-L copper risers that meet or exceed the requirements stated above.
- b. Risers shall be insulated with 1/2" (13) closed cell foam insulation covering the entire riser. Insulation shall conform to NFPA 90A and carry no more than a 25/50 Flame Spread and Smoke Developed Rating, per ASTM E-84 and UL 723.

Optional

- Provide 3/4" (19) closed cell foam insulation that meets or exceeds the requirements stated above.
- c. Condensate drain risers shall be Type-M seamless copper tube and meet the requirements stated above.

Optional

- Risers shall be factory fabricated, bundled, and tagged separate from the fan coil units, allowing for shipment and installation of

risers prior to the fan coil units. The riser tag must show the corresponding FCU tag, floor number, room number, riser number, CW, HW, and condensate pipe diameters. Refer to submittal drawing on ship separate/loose riser assembly.

13. Outside Air Damper

Optional

- Provide a manual outside air damper with hand-locking quadrant.
- Provide a motorized outside air damper integral to the unit. The damper actuator shall be spring return closed.