

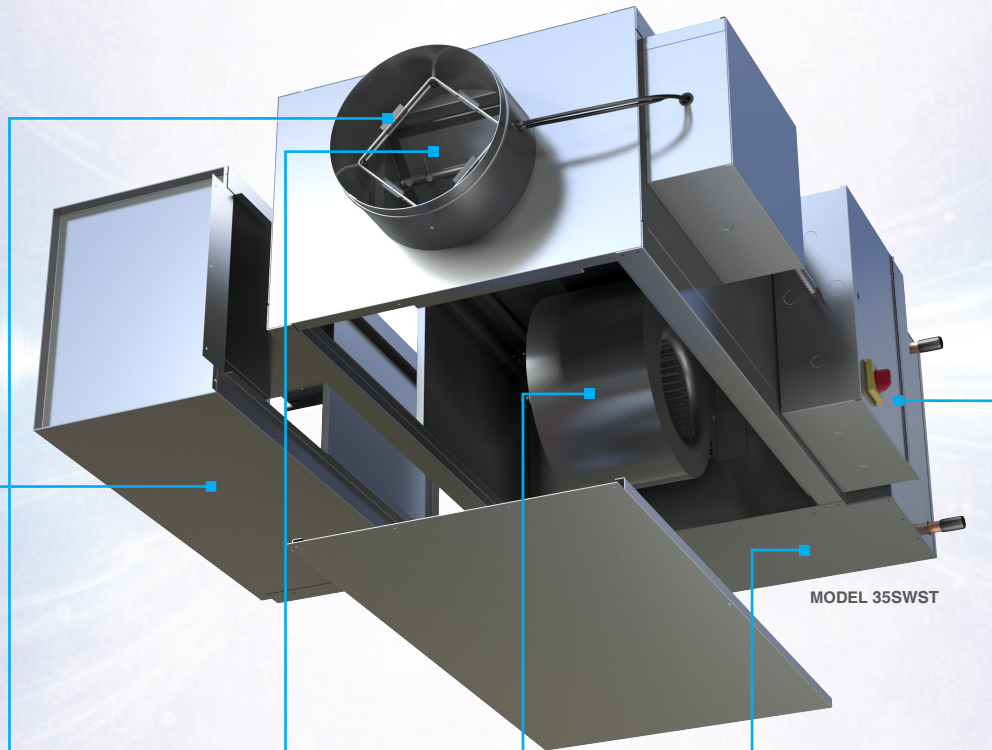

IN A NOISY MARKET, SOMETIMES IT'S BEST TO BE THE QUIETEST.

NAILOR'S **STEALTH™** FAN POWERED TERMINAL UNIT



MODEL 35SWST

QUIETEST TERMINAL UNITS

The STEALTH™ Units provide industry-leading sound performance, offering top-level efficiency and noise attenuation



ACCURACY AND RELIABILITY THROUGH DURABILITY

Nailor's Diamond Flow Inlet Sensor is a highly durable and accurate pressure measurement device designed with aluminum construction for enhanced long-term strength and reliability

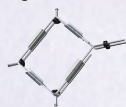

OPPOSED BLADE DAMPER UPGRADE

Provides lower pressure drop and noise reduction versus a conventional butterfly damper

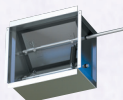

ECM MOTOR W/ EPIC FAN TECHNOLOGY™

Delivers pressure-independent fan operation saving more energy than it uses.



EFFICIENCY GAINS WITH FULLY ENCASED WATER COILS

All of Nailor's STEALTH™ Units come standard with fully encased water coils, mitigating heat loss and improving efficiency

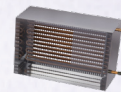

NAILOR IS AHRI CERTIFIED AND ETL LISTED



NAILOR IS 100% INDEPENDENTLY CERTIFIED



2026 marks the 30th anniversary of Nailor launching its industry-leading STEALTH™ Series Fan Powered Terminal Units. Since then, we've continued to improve, refine and innovate the line. In that time, there have been many attempts to imitate, but the STEALTH™ Line still remains unmatched. For three decades, the units have led the market in **Sound, Efficiency and Functionality**, and have been a catalyst of many technological and application advancements in the HVAC Industry. Nailor's STEALTH™ Fan Powered Terminal Units, **PERFORMANCE THAT'S QUIET REMARKABLE.**

SCAN HERE TO LEARN MORE ABOUT NAILOR'S STEALTH LINE



nailor.com

U.S.A. • CANADA • U.K.

