

QUALIFICATIONS:

- **UL 263 CLASSIFIED CEILING DAMPER.** Category CABS. (File # R9660).
- 1 hour rated for use in UL floor/ceiling design numbers L528/L546/L550/L558/L562/L574/L576/L579/L581/L583/L585/M501/M503 and roof/ceiling design numbers P531/P533/P538/P545/P547/P552. (Other proprietary UL design numbers may be similar. Local approval by AHJ is required to use a Nailor design when not specified).
- Meets NFPA 90A requirements.

DESCRIPTION:

Ceiling dampers are designed to function as a heat barrier in air handling openings penetrating fire resistive membrane ceilings. Model 0756 has been especially designed and tested to provide protection and simple installation in specific UL design wood truss ceiling assemblies.

The 0756 assembly consists of a rectangular ceiling damper recessed in a sheet metal register box (boot) with a round inlet collar, that accommodates a steel grille register or diffuser.

STANDARD CONSTRUCTION:

1. **Fusible Link:** UL Listed, 212°F (100°C), standard.
2. **Blades:** 22 ga. (0.85) roll-formed galv. steel.
3. **Blade Insulation:** Non-asbestos UL Classified.
4. **Damper Frame:** 22 ga. (0.85) galvanized steel.
5. **Steel Plenum/ Sub-Frame:** 26 ga. (0.55) minimum with round connection collar.
6. **Duct:** UL Classified Class 0 or 1 flexible air duct connection by others.
7. **Flange:** 5/8" (16) plaster flange.
8. **Steel Grille/ Register/Diffuser:** sub-frame is flush with ceiling. Standard depth for grille clearance is 2 1/2" (64).

Model 0756 Sizes (W x H):

Minimum	Maximum
6" x 4" (152 x 102)	16" x 12" (406 x 305)

W x H =
Nominal Grille/
Register Size

Available Duct Connection Size: 4" through 10" (102 – 254) dia. Building code and UL Classification require damper installation in accordance with manufacturers instructions.

OPTIONS:

1. Non-standard temp. UL listed fusible link
 165 165°F (74°C)
2. Damper Style:
 0716 Butterfly (Two Blades) Damper standard
 0714 Single Blade Damper
3. Installation Support Angles. 26" (660) long.
 ISA 2 @ 3/4" x 3/4" x 16 ga. (19 x 19 x 1.6) or
 ISB 2 @ 1 1/2" x 1 1/2" x 22 ga. (38 x 38 x 0.85)

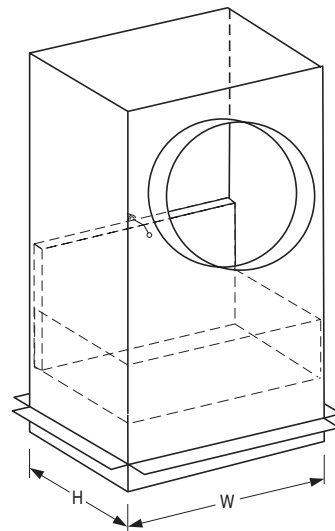
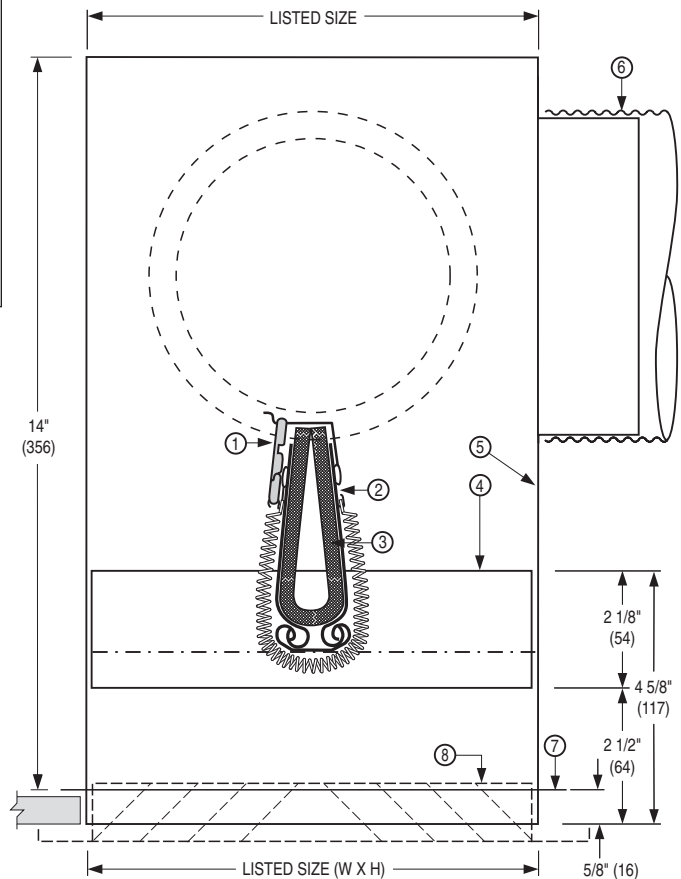

Note:

0716 style damper shown above is standard. 0714 Single Blade is also available (left), which places damper out of the airstream.

For installation instructions, see IOM-CRD0756INST.

SCHEDULE TYPE:	Dimensions are in inches (mm)			
PROJECT:				
ENGINEER:	DATE	B SERIES	SUPERSEDES	DRAWING NO.
CONTRACTOR:	9 - 13 - 21	0700	7 - 11 - 16	0756