



**CEILING RADIATION DAMPER**  
**FOR WOOD TRUSS CEILING ASSEMBLIES**  
**INSULATED REGISTER BOX • TOP INLET**  
**MODEL: 0763-GB**



**QUALIFICATIONS:**

- **UL 263 CLASSIFIED CEILING RADIATION DAMPER. Category CABS. (File # R9660).**
- **1 hour rated for use in UL floor/ceiling design numbers L528/L546/L550/L558/L574/L576/L579/L581/L583/L585/M503 and roof/ceiling design numbers P531/P533/P545/P547/P552. (Other proprietary UL design numbers may be similar. Local approval by AHJ is required to use a Nailor design when not specified).**
- **Meets NFPA 90A requirements.**

**DESCRIPTION:**

Ceiling dampers are designed to function as a heat barrier in air handling openings penetrating fire resistive membrane ceilings. The Model 0763-GB has been especially designed and tested to provide protection and simple installation in specific UL design wood truss ceiling assemblies.

The 0763-GB assembly consists of a ceiling damper mounted in the round top inlet collar of a Type GB internally insulated sheet metal register box (boot) that accommodates a steel grille or register.

**STANDARD CONSTRUCTION:**

- 1. Fusible Link:** UL Listed, 212°F (100°C), standard.
- 2. Blades:** 22 ga. (0.85) roll-formed galv. steel.
- 3. Blade Insulation:** Non-asbestos UL Classified.
- 4. Damper Frame:** 22 ga. (0.85) galvanized steel.
- 5. Internal Insulation:** 1 1/2" (38) R-6.3 value.
- 6. Plenum:** Steel. 28 ga. (0.47) min. with round connection collar.
- 7. Duct:** UL Classified Class 0 or 1 flexible air duct connection by others.
- 8. Flange:** Plaster flange.
- 9. Steel Grille/Reg.:** By Nailor or others. Minimum depth for grille clearance is 2" (51).

**OPTIONS:**

- R8** 2" (51) thick R-8 value insulation.
- Non-standard temperature U.L. Listed fusible link.  
 **165** 165°F (74°C)
- Installation Support Angles. 26" (660) long.  
 **ISA** 2 @ 3/4" x 3/4" x 16 ga. (19 x 19 x 1.6) or  
 **ISB** 2 @ 1 1/2" x 1 1/2" x 22 ga. (38 x 38 x 0.85)

**NOTE:**

Building code and UL Classification require damper installation in accordance with manufacturer's instructions. See IOM-CRD0763INST.

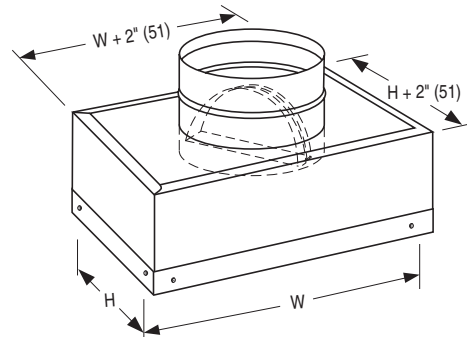
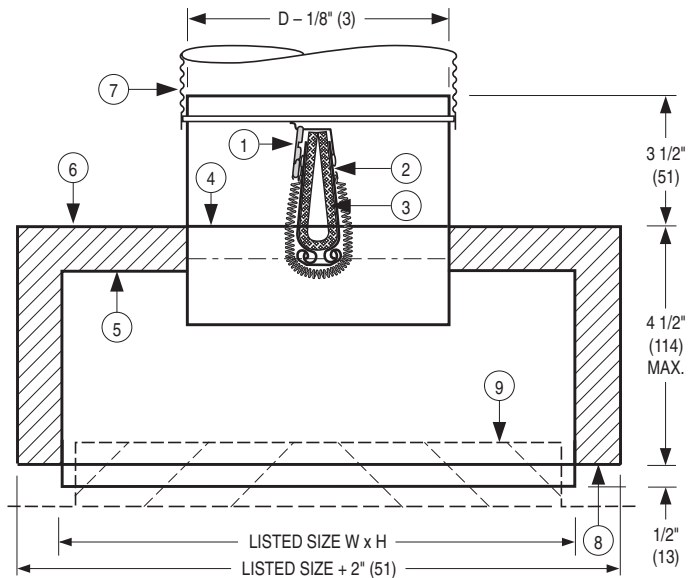

**Dimensional Data (W x H):**

Available Sizes	
W x H	Nominal Duct Size D
8" x 4" (203 x 102)	4", 5" (102, 127) dia.
10" x 4" (254 x 102)	4", 5", 6" (102, 127, 152) dia.
12" x 4" (305 x 102)	6", 7", 8" (152, 178, 203) dia.
8" x 6" (203 x 152)	6" (152) dia.
10" x 6" (254 x 152)	5", 6", 7" (127, 152, 178) dia.
12" x 6" (305 x 152)	6", 7", 8" (152, 178, 203) dia.
14" x 6" (356 x 152)	6", 7", 8" (152, 178, 203) dia.
8" x 8" (203 x 203)	5", 6" (127, 152) dia.
10" x 8" (254 x 203)	7", 8" (178, 203) dia.
12" x 8" (305 x 203)	7", 8" (178, 203) dia.
14" x 8" (356 x 203)	6", 7", 8" (152, 178, 203) dia.

W x H = Nominal Grille/Register Size

<b>SCHEDULE TYPE:</b>	Dimensions are in inches (mm)			
<b>PROJECT:</b>				
<b>ENGINEER:</b>	<b>DATE</b>	<b>B SERIES</b>	<b>SUPERSEDES</b>	<b>DRAWING NO.</b>
<b>CONTRACTOR:</b>	9 - 16 - 21	0700	7 - 11 - 16	0763-GB