



LOW LEAKAGE CONTROL DAMPER
STEEL • STANDARD PERFORMANCE
MODELS: 1010 & 1020 WITH 304 STAINLESS STEEL
CONSTRUCTION OPTION

Nailor Models 1010/1020 with optional 304 Stainless Steel construction provide an enduring solution for corrosive environment commercial and industrial HVAC and process applications. The proven vee groove blade design and sturdy hat channel mitered frame with reinforcing corner gussets afford solid performance that will withstand many normally harsh atmospheric and process elements. The design also features stainless steel zero-maintenance concealed blade linkage for reduced pressure drop and turbulence, and stainless steel axles, bushings and hardware for long lasting operation.

RATINGS:

Velocity: Up to 3000 fpm (15.2 m/s)
Pressure: Up to 5" wg. (1.2 kPa)
Leakage: 4 cfm/sq. ft. @ 1" wg (20 l/s/m² @ 0.25 kPa)
 8 cfm/sq. ft. @ 4" wg (41 l/s/m² @ 1.0 kPa)

Temperature

Range: -50°F to +180°F (-46°C to +82°C).

STANDARD CONSTRUCTION:

Frame: 5" x 7/8" x 16 ga. (127 x 22 x 1.6) Type 304 stainless steel hat channel with stainless steel corner gussets. Frame and corner gussets are welded for rigidity. Low profile (flat top and bottom) on dampers 10" (254) high and under.

Blades: 6" (152) wide on 5 1/2" (140) centers. 16 ga. (1.6) Type 304 stainless steel vee groove design. Parallel or opposed action.

Linkage: Concealed type totally enclosed within the frame and out of the airstream. Type 304 stainless steel.

Bearings: 1/2" (13) dia. Celcon®.

Axles: 1/2" (13) dia. stainless steel double bolted to blades.

Drive Shaft: 6" (152) long x 1/2" (13) dia. Type 304 stainless steel lock-on drive shaft on all single section dampers. A 1/2" (13) or 1" (25) dia. factory installed jackshaft is standard on all multiple section dampers. See multi-section detail 1000 MSI.

Blade Seals: Dual durometer bulb type extruded PVC.

Jamb Seals: Compression type cambered stainless steel.

Sizes (Duct W x H):

Minimum		Maximum	
Single Section		Single Section	Multiple Section
Single Blade 6" x 4" (152 x 102)	Two Blades (parallel or opposed) 6" x 10" (152 x 254)	48" x 72" (1219 x 1829)	Unlimited

OPTIONS:

- AMP Actuator mounting side plate
- Other _____.

Nailor offers a wide selection of pneumatic and electric actuators for factory or field installation.

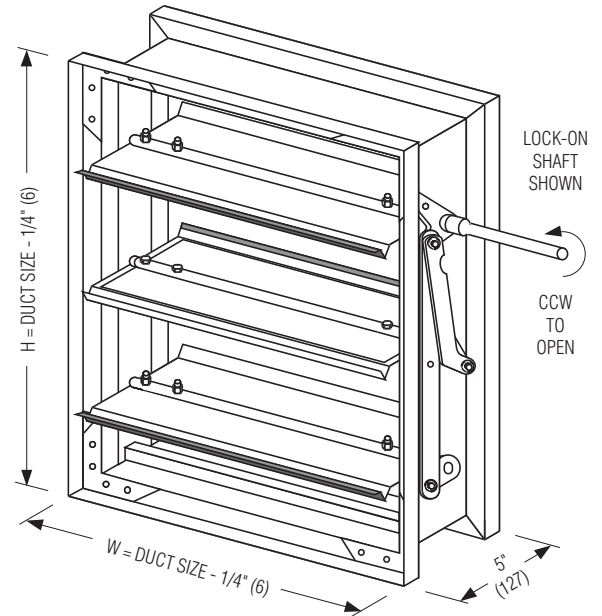

MODEL 1010-304 STAINLESS STEEL CONST. PARALLEL BLADE

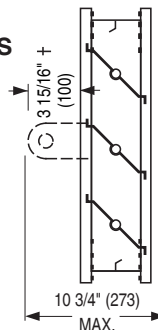

† jackshaft standard on multiple section dampers.

MODEL 1020-304 STAINLESS STEEL CONST. OPPOSED BLADE

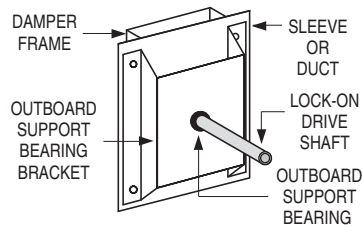
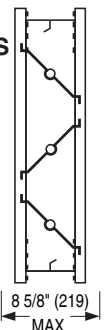

Lock-on drive shaft support bracket detail.

The low profile frame illustrated is used to maximize free area available on units 10" (254) high and under.

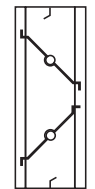

SCHEDULE TYPE:

PROJECT:

ENGINEER:

CONTRACTOR:

Page 1 of 2
 Dimensions are in inches (mm).

DATE	C SERIES	SUPERSEDES	DRAWING NO.
5 - 15 - 26	1000	4 - 14 - 26	1000-1C



LOW LEAKAGE CONTROL DAMPER
STEEL • STANDARD PERFORMANCE
MODELS: 1010 & 1020 WITH 304 STAINLESS STEEL
CONSTRUCTION OPTION • PERFORMANCE DATA

PERFORMANCE DATA:
MODELS: 1010 AND 1020

FRAME OPTIONS:

- FF Flanged Front FR Flanged Rear FD Double Flange

PRESSURE DROP (damper fully open):

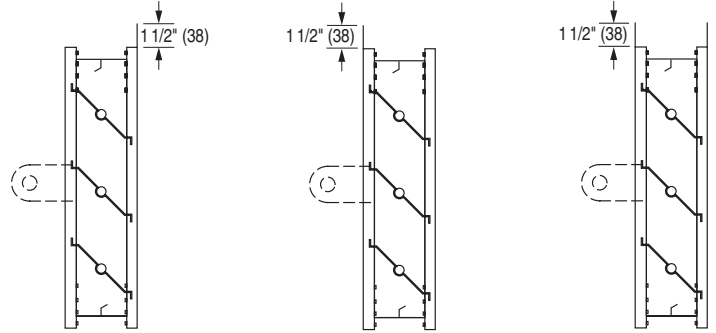
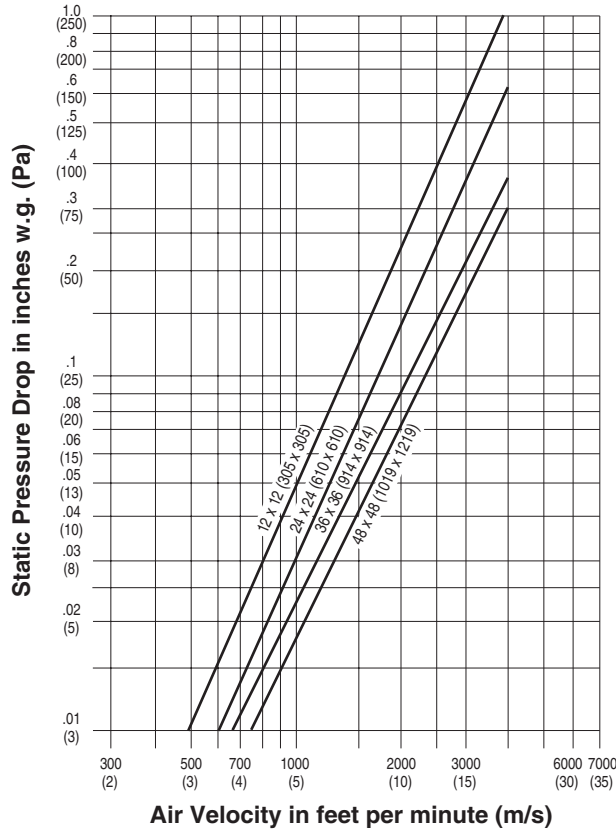

DYNAMIC LIMITATIONS/LEAKAGE

Damper Width	Maximum System Pressure	Maximum System Velocity	Leakage *	
			% of Max. Flow	Cfm/ Sq. Ft.
48" (1219)	2.5" w.g.	3000 fpm	0.18	3.5
36" (914)	3.0" w.g.	3000 fpm	0.2	4.0
24" (610)	4.0" w.g.	3000 fpm	0.23	4.5

* Leakage information is based upon a pressure differential of 1" w.g. tested per AMCA standard 500-D, Fig. 5.5.

SCHEDULE TYPE:		Page 2 of 2			
PROJECT:		Dimensions are in inches (mm).			
ENGINEER:	DATE	C SERIES	SUPERSEDES	DRAWING NO.	
CONTRACTOR:	5 - 15 - 26	1000	4 - 14 - 26	1000-1C	