

The 1010/20 Series are Nailor's most widely used low leakage control dampers and are the standard choice for use in the majority of low to medium velocity and pressure commercial HVAC systems. They are low cost, high quality dampers that meet or exceed the majority of standard specification requirements. They meet the frequently specified leakage criteria of less than 10 cfm per sq. ft. @ 4" w.g. The design features include a sturdy hat channel frame with die-formed corner gussets for reinforcement and structural strength, a vee groove blade design that maximizes strength and zero maintenance concealed linkage (out of the air stream) for reduced pressure drop and air turbulence.

RATINGS:

VELOCITY: Up to 3000 fpm (15.2 m/s)
PRESSURE: Up to 5" wg (1.2 kPa)
LEAKAGE: 4 cfm/sq. ft. @ 1" wg (20 l/s/m² @ 0.25 kPa)
 8 cfm/sq. ft. @ 4" wg (41 l/s/m² @ 1.0 kPa)

TEMPERATURE RANGE: -50°F to +180°F (-46°C to +82°C).

STANDARD CONSTRUCTION:

FRAME: 5" x 7/8" x 16 ga. (127 x 22 x 1.6) galvanized steel hat channel with die-formed corner gussets. Low profile (flat top and bottom) on dampers 10" (254) high and under.

BLADES: 6" (152) wide on 5 1/2" (140) centers. 16 ga. (1.6) galv. steel vee groove design. Parallel or opposed action.

LINKAGE: Concealed type totally enclosed within the frame and out of the airstream. Plated steel.

BEARINGS: 1/2" (13) dia. Celcon[®].

AXLES: 1/2" (13) dia. plated steel double bolted to blades.

DRIVE SHAFT: 6" (152) long x 1/2" (13) dia. rigid drive shaft on all single section dampers. A 1/2" (13) or 1" (25) dia. factory installed jackshaft is standard on all multiple section dampers. See multi-section detail 1000 MSI.

BLADE SEALS: Dual durometer bulb type extruded PVC.

JAMB SEALS: Compression type cambered metal.

Sizes (Duct W x H):

Minimum		Maximum	
Single Section		Single Section	Multiple Section
Single Blade 6" x 4" (152 x 102)	Two Blades (parallel or opposed) 6" x 10" (152 x 254)	48" x 72" (1219 x 1829)	Unlimited

OPTIONS:

- BO** Oilite bearings
- 304** Type 304 Stainless Steel construction
- SMP** Actuator side mounting plate
- DLO** Lock-on drive shaft
- Other _____

Nailor offers a wide selection of electric actuators for factory or field installation.

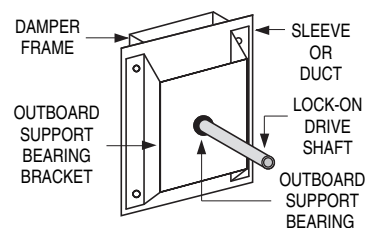
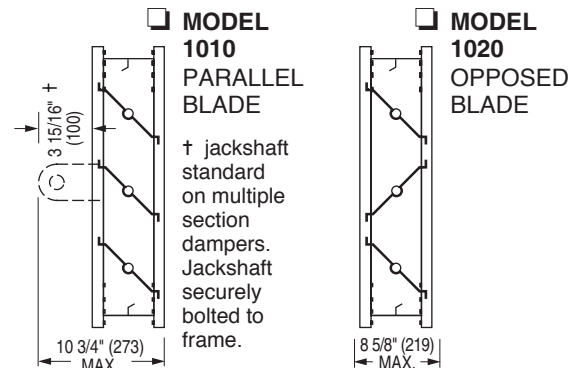
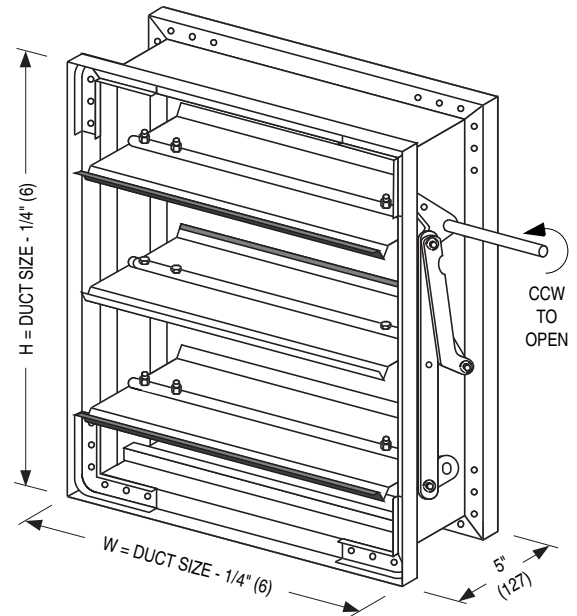

Optional lock-on drive shaft support bracket detail.

The low profile frame illustrated is used to maximize free area available on units 10" (254) high and under.

SCHEDULE TYPE:
PROJECT:
ENGINEER:
CONTRACTOR:

Page 1 of 2
 Dimensions are in inches (mm).

DATE	A SERIES	SUPERSEDES	DRAWING NO.
4 - 13 - 26	1000	2 - 13 - 26	1000-1

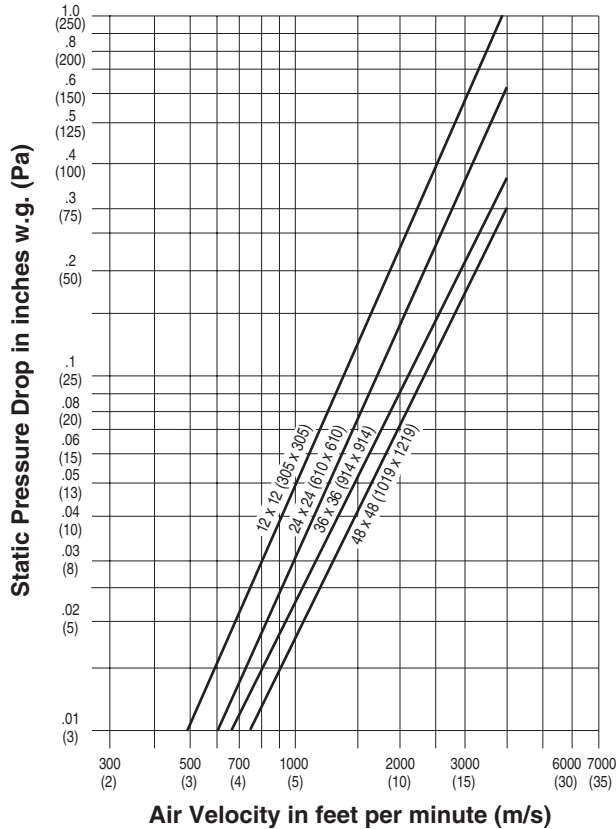
PERFORMANCE DATA:
MODELS: 1010 AND 1020
PRESSURE DROP (damper fully open):

FRAME OPTIONS:

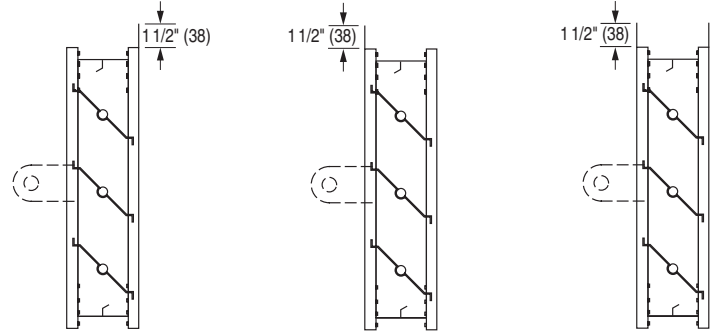
-
- FF**
- Flanged Front
-
- FR**
- Flanged Rear
-
- FD**
- Double Flange

DYNAMIC LIMITATIONS/LEAKAGE

Damper Width	Maximum System Pressure	Maximum System Velocity	Leakage *	
			% of Max. Flow	Cfm/ Sq. Ft.
48" (1219)	2.5" w.g.	2000 fpm	0.18	3.5
36" (914)	3.0" w.g.	2000 fpm	0.2	4.0
24" (610)	4.0" w.g.	2000 fpm	0.23	4.5
12" (305)	5.0" w.g.	2000 fpm	0.33	6.6

* Leakage information is based upon a pressure differential of 1" w.g. tested per AMCA standard 500-D, Fig. 5.5.

SCHEDULE TYPE:
PROJECT:
ENGINEER:
CONTRACTOR:

 Page 2 of 2
 Dimensions are in inches (mm).

DATE
A SERIES
SUPERSEDES
DRAWING NO.

4 - 13 - 26

1000

2 - 13 - 26

1000-1