



STATIC MULTI-BLADE FIRE DAMPER
 FOR USE IN STATIC SYSTEMS
 HIGH PERFORMANCE
 AIRFOIL BLADE • ROUND DUCT CONNECT.
MODEL: 1203 (TYPE C SLEEVE ENCLOSURE)



QUALIFICATIONS:

- **UL 555 & CAN/ULC-S112 CLASSIFIED FIRE DAMPER**
1 1/2 hr. Label (File #'s R9492 & R19569).
- **Meets NFPA 90A, BOCA, SBCCI, UBC, IBC, NBC (Canada)**
and associated local building code requirements.
- **California State Fire Marshal Listing No. 03225-0935:101.**
- **City of New York. MEA# 366-03-M.**

The 1200 Series Dampers are ideal for applications where building codes require a fire damper for the protection of ductwork penetrations in walls or floors that have a fire resistance rating of up to 2 hours.

The 1200 Series is classified for use only in static "fans off" systems where the HVAC system is automatically shut down in the event of a fire alarm.

The 1200 Series has been especially designed and tested to provide premium performance. Airfoil blade design and elimination of blade sills, top and bottom, provide a low pressure drop design.

The 1200 Series features the industry proven over-center knee-lock design with high torque spring/fusible link closure.

Unique, inter-locking double skin blade design provides flame and smoke seal under fire conditions.

The 1200 is supplied as standard with an internal locking quadrant which holds the damper in the fully open position, but may also be used for system balancing if required.

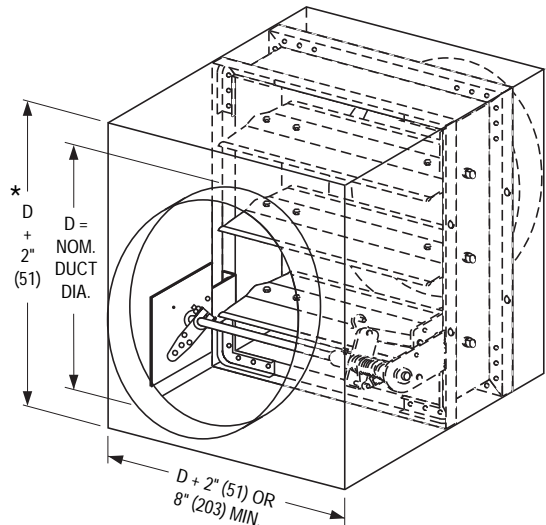

* or 8" (203) min.

STANDARD SPECIFICATION:

- Frame:** 5" x 7/8" x 16 ga. (127 x 22 x 1.6) galvanized steel hat channel.
- Blades:** 14 ga. (2.0) equivalent galvanized steel formed airfoil on 5 1/2" (140) centers. Opposed action.
- Linkage:** Concealed in frame. 12 ga. (2.7) plated steel.
- Bearings:** 1/2" (13) dia. self-lubricating oilite bronze.
- Axles:** 1/2" (13) dia. plated steel double bolted to blades.
- Jackshaft:** 1/2" (13) dia. cadmium plated steel. Internal locking quadrant is factory installed.
- Fusible Link:** 165°F (74°C) standard. 212°F (100°C) available.
- Min. Duct Size:** Vertical or Horizontal mount: 4" (102) diameter. (Overall damper size is 8" x 8" [203 x 203] min.).
- Max. Duct Size:** Single Section
 Vertical mount: 34" (864) diameter.
 Horizontal mount: 30" (762) diameter.
 Multiple Section Assembly
 Vertical or Horizontal mount: 94" (2388) diameter.

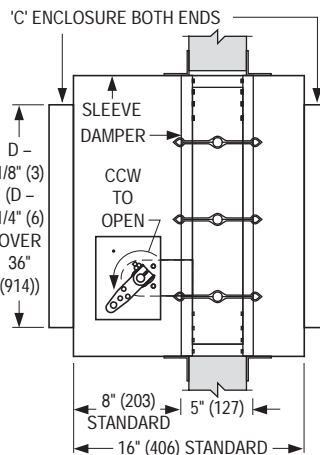

Wall Thickness	Minimum Sleeve Length
4 (102)	16 (406)
8 (203)	20 (508)
12 (305)	24 (610)
16 (406)	28 (711)

SLEEVE/ENCLOSURE SELECTION:

- 1203** Standard factory sleeve 16" long x 20 ga. (406 x 1.0).
- 1203** Non-standard sleeve. Specify _____ length _____ ga. Available up to 36" (914) dependent upon wall thickness and 10 through 20 ga. (3.5 through 1.0).

OPTIONS:

- BS** Stainless steel bearings
- MLS-300** Position indicator switch pack
- JSM** Flexible metal jamb seals
- QS1** Quick-set retaining angle (one side)
- QS2** Quick-set retaining angles (two sides)
- Special features** _____

For installation instructions, see IOM-MBFDINST.

SCHEDULE TYPE:		Dimensions are in inches (mm).			
PROJECT:					
ENGINEER:	DATE	B SERIES	SUPERSEDES	DRAWING NO.	
CONTRACTOR:	1 - 1 - 12	1200	11 - 21 - 07	1200-3	