



STAINLESS STEEL SMOKE DAMPER
AIRFOIL BLADE • HIGH PERFORMANCE
ULTRA-LOW LEAKAGE • LOW PRESSURE DROP
MODELS: 1210SS AND 1211SS (TYPE A)



QUALIFICATIONS:

- **UL 555S CLASSIFIED SMOKE DAMPER (File # R9492)** Leakage Class I or II at 250°F elevated temperature.
- Meets NFPA 90A, 92A, 92B, 101 and 105 as well as IBC and NBC (Canada) Building Code requirements.
- California State Fire Marshal Listing No. 03230-0935:107.
- City of New York MEA# 366-03-M.
- **Maximum velocity: 2000 fpm @ 4" w.g.**

The 1210SS Series dampers are ideal for high humidity, mildly corrosive or, with optional Type 316 construction, more severe environments where building codes require a leakage rated smoke damper as part of a static smoke control or dynamic smoke management system.

The 1210SS Series has been especially designed and tested to offer premium performance. The 1210SS Series provides the lowest leakage class available and is qualified for vertical or horizontal installation with airflow in either direction. Airfoil blade design and elimination of blade sills, top and bottom, provide lowest pressure drop. Unique inter-locking double skin blade design eliminates combustible blade seals and provides flame and smoke seal under fire conditions.

STANDARD SPECIFICATION:

- Frame:** 5" x 7/8" x 16 ga. (127 x 22 x 1.6) stainless steel hat channel.
- Blades:** 14 ga. (2.0) equivalent stainless steel formed airfoil on 5 1/2" (140) centers. Opposed action.
- Linkage:** Concealed in frame. 12 ga. (2.7) stainless steel.
- Bearings:** 1/2" (13) dia. sintered stainless steel.
- Axles:** 1/2" (13) dia. stainless steel double bolted to blades.
- Jackshaft:** 1/2" (13) dia. stainless steel.
- Jamb Seals:** Cambered stainless steel.
- Sizes (Damper W x H):**

Velocity/ Pressure Rating	Elevated Temp. °F	Minimum		Maximum	
		Single Section	Single Section	Multiple Section	
		Vertical/Horizontal	Vertical/Horizontal	Vertical/Horizontal	Vertical/Horizontal
24	250	8" x 8" (203 x 203)	36" x 48" (914 x 1219)	144" x 96" (3658 x 2438)	

Note: Dampers with duct heights less than 8" (203) require a Type 'B' sleeve enclosure (Model 1212SS). Units less than 8" (203) in width only, or in both width and height, require a Type 'C' enclosure (Model 1213SS).

BASE MODEL SELECTION:

- 1210SS** With side actuator mounting plate
- 1211SS** Standard factory sleeve (caulked to UL requirements) 16" long x 20 ga. (406 x 1.0) (18 ga. for dampers over 84" [2134] in width).
- 1211SS** Non-standard sleeve.
Specify _____ length _____ ga.
Available up to 36" (914) in length and 10 through 20 ga. (3.5 through 1.0).

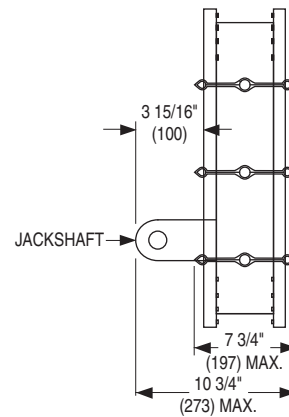
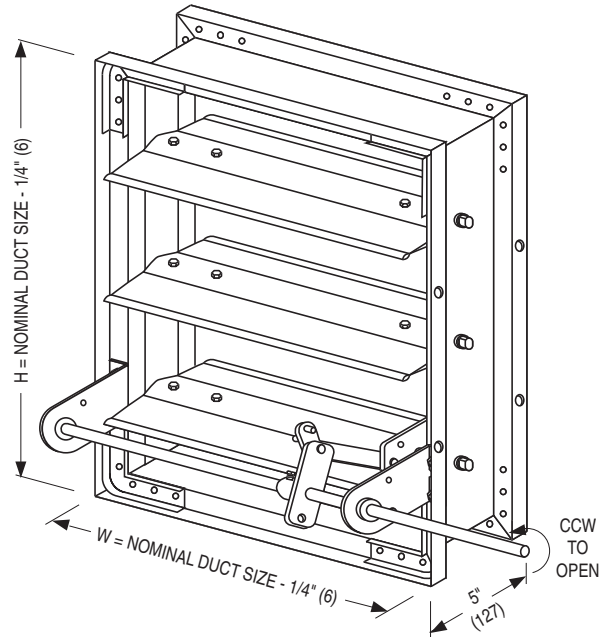

CONSTRUCTION TYPE:

- 304** Type 304 Stainless Steel construction (Standard).
- 316** Type 316 Stainless Steel construction (Optional).

LEAKAGE CLASS/ELEVATED TEMPERATURE:

- I** **II** @ 250°F

DYNAMIC VELOCITY/PRESSURE RATING:

24 2000 fpm @ 4" w.g.

ACTUATOR SELECTION:

- Electric** **Pneumatic**

ACTUATOR LOCATION:

- External** (std.) **Internal** (in the airstream)

ACTUATOR FAIL POSITION:

- Normally Closed** (std.) **Normally Open**

OPTIONS:

- MLS-300** Position indicator switch pack

SCHEDULE TYPE:

PROJECT:

ENGINEER:

CONTRACTOR:

For installation instructions, see IOM-SDINST.
 Dimensions are in inches (mm).

DATE	B SERIES	SUPERSEDES	DRAWING NO.
5 - 7 - 12	1200	3 - 21 - 11	1210SS-1