



SMOKE DAMPER
VERTICAL AIRFOIL BLADE
ROUND DUCT CONNECTION
HIGH PERFORMANCE
MODEL: 1213VB (TYPE C SLEEVE ENCLOSURE)



QUALIFICATIONS:

- **UL 555S CLASSIFIED SMOKE DAMPER (File # R9492)**
Leakage Class I or II at 250°F elevated temperature.
- Meets NFPA 90A, 92A, 92B, 101 and 105 as well as IBC and NBC (Canada) Building Code requirements.
- California State Fire Marshal Listing No. 03230-0935:107.
- City of New York. MEA # 366-03-M.
- Maximum velocity: 2000 fpm @ 4" w.g.

Model 1213VB (Vertical Blade) is a high performance smoke damper that provides superior protection and versatility. The vertical blade configuration allows for the actuator to be mounted below the damper and is ideal for applications where bottom access is desired or where there isn't space for a side mounted actuator.

The 1210VB Series dampers are ideal for applications where building codes require a leakage rated smoke damper as part of a static smoke control or dynamic smoke management system.

The 1210VB Series has been especially designed and tested to provide premium performance. It offers the lowest leakage class available and is qualified for installation with airflow in either direction. Airfoil blade design and elimination of blade sills provide low pressure drop.

Unique, inter-locking double skin blade design eliminates combustible blade seals and provides flame and smoke seal under fire conditions.

STANDARD SPECIFICATION:

- Frame:** 5" x 7/8" x 16 ga. (127 x 22 x 1.6) galvanized steel hat channel.
Blades: 14 ga. (2.0) equivalent galvanized steel formed airfoil on 5 1/2" (140) centers. Opposed action.
Linkage: Concealed in frame. 12 ga. (2.7) plated steel.
Bearings: 1/2" (13) dia. self-lubricating oilite bronze.
Axles: 1/2" (13) dia. plated steel double bolted to blades.
Jackshaft: 1/2" (13) dia. cadmium plated steel.
Jamb Seals: Stainless steel.

Sizes (Duct Diameter):

| Velocity/ Pressure Rating | Elevated Temp. °F | Minimum | Maximum |
|---------------------------------|-------------------------|---|----------------------------|
| | | Single Section Vertical | Single Section Vertical |
| 24 | 250 | 4" (102) dia. (overall damper size is 8" x 8" [203 x 203]). | 34" (864) dia. |

Note: Multiple Section Assemblies are not permitted.

SLEEVE/ENCLOSURE SELECTION:

- 1213VB** Standard factory sleeve (caulked to UL requirements) 16" long x 20 ga. (406 x 1.0).
- 1213VB** Non-standard sleeve. Specify _____ length ____ ga. Available up to 36" (914) dependent upon wall thickness and 10 through 20 ga. (3.5 through 1.0).

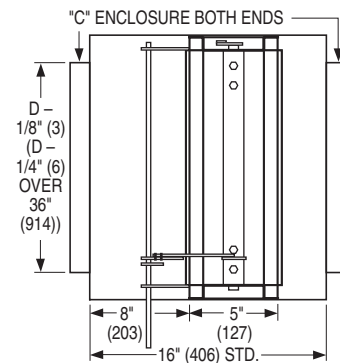
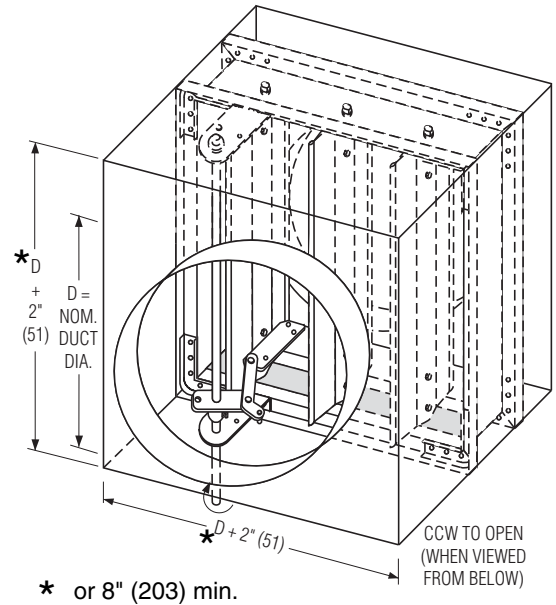

LEAKAGE CLASS/ELEVATED TEMPERATURE:

- I II @ 250°F

DYNAMIC VELOCITY/PRESSURE RATING:

24 2000 fpm @ 4" w.g.

ACTUATOR SELECTION: Electric.

ACTUATOR LOCATION: External, bottom mount.

ACTUATOR FAIL POSITION: Closed.

OPTIONS:

- BS** Stainless steel bearings
- MLS-300** Position indicator switch pack

For installation instructions, see IOM-SDINST.

| | | | | |
|-----------------------|--------------------------------|-----------------|-------------------|--------------------|
| SCHEDULE TYPE: | Dimensions are in inches (mm). | | | |
| PROJECT: | | | | |
| ENGINEER: | DATE | B SERIES | SUPERSEDES | DRAWING NO. |
| CONTRACTOR: | 5 - 7 - 12 | 1200 | 11 - 28 - 11 | 1210VB-3 |