



STAINLESS STEEL COMBINATION FIRE/SMOKE DAMPER
AIRFOIL BLADE • HIGH PERFORMANCE
3 HR. LABEL • ULTRA-LOW LEAKAGE
MODELS: 1220SS-3 AND 1221SS-3 (TYPE A)



QUALIFICATIONS:

- UL 555 & CAN/ULC-S112 CLASSIFIED DYNAMIC FIRE DAMPER 3 hr. Label (File # R9492).
- UL 555S & CAN/ULC-S112.1 CLASSIFIED SMOKE DAMPER Leakage Class I or II at 250°F elevated temperature (File # R9492).
- City of New York MEA #366-03-M.
- California State Fire Marshal: Fire Damper Listing No. 3225-0935:106.
- Meets NFPA 80, 90A, 92A, 92B, 101 and 105 as well as IBC and NBC (Canada) Building Code requirements.
- Maximum velocity: 2000 fpm @ 4" w.g.

The 1220SS-3 Series dampers are ideal for high humidity, mildly corrosive or, with optional Type 316 construction, more severe environment applications where building codes require both a fire damper for the protection of ductwork penetrations in walls that have a fire resistance rating of up to 4 hours and also require a leakage rated damper for operational smoke control in static or dynamic smoke management systems.

The 1220SS-3 Series has been especially designed and tested to provide premium performance. It offers the lowest leakage class available and is qualified for installation with airflow in either direction and inverted mounting. Airfoil blade design and elimination of blade sills, top and bottom, provide a low pressure drop design.

Unique, inter-locking double skin blade design provides flame and smoke seal under fire conditions.

STANDARD SPECIFICATION:

- Frame:** 5" x 7/8" x 16 ga. (127 x 22 x 1.6) stainless steel hat channel.
Blades: 14 ga. (2.0) equivalent stainless steel formed airfoil on 5 1/2" (140) centers. Opposed action.
Linkage: Concealed in frame. 12 ga. (2.7) stainless steel.
Bearings: 1/2" (13) dia. sintered stainless steel.
Axles: 1/2" (13) dia. stainless steel double bolted to blades.
Jackshaft: 1/2" (13) dia. stainless steel.
Jamb Seals: Cambered stainless steel.

Heat Responsive Device (Controlled Closure):

ERL (Electric Resettable Link) is standard on dampers with electric actuators: 250°F (121°C) standard. 165°F (74°C) and 212°F (100°C) available.
 PRL (Pneumatic Replaceable Link) is standard on dampers with pneumatic actuators: 212°F (100°C) standard. 165°F (74°C) available.

Sizes (Damper W x H):

Velocity/ Pressure Rating	Elevated Temp. °F	Minimum		Maximum	
		Single Section	Single Section	Multiple Section	Multiple Section
		Vertical	Vertical	Vertical	Vertical
24	250	8" x 8" (203 x 203)	30" x 48" (762 x 1219)	120" x 96" (3048 x 2438)	

Note: Dampers with duct heights less than 8" (203) require a Type 'B' sleeve enclosure (Model 1222SS-3). Duct sizes less than 8" (203) in width only, or in both width and height require a Type 'C' enclosure (Model 1223SS-3).

BASE MODEL SELECTION:

- 1220SS-3 With side actuator mounting plate
- 1221SS-3 Standard factory sleeve (caulked to UL requirements) 16" long x 20 ga. (406 x 1.0) (18 ga. [1.3] for dampers over 84" [2134] in width).
- 1221SS-3 Non-standard sleeve. Specify _____ length _____ ga. Available up to 36" (914) dependent upon wall thickness and 10 through 20 ga. (3.5 through 1.0).

CONSTRUCTION TYPE:

- 304 Type 304 Stainless Steel construction (Standard).
- 316 Type 316 Stainless Steel construction (Optional).

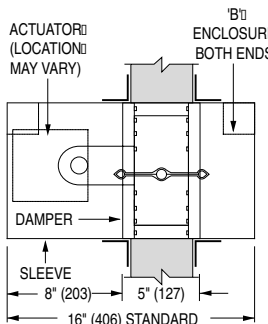
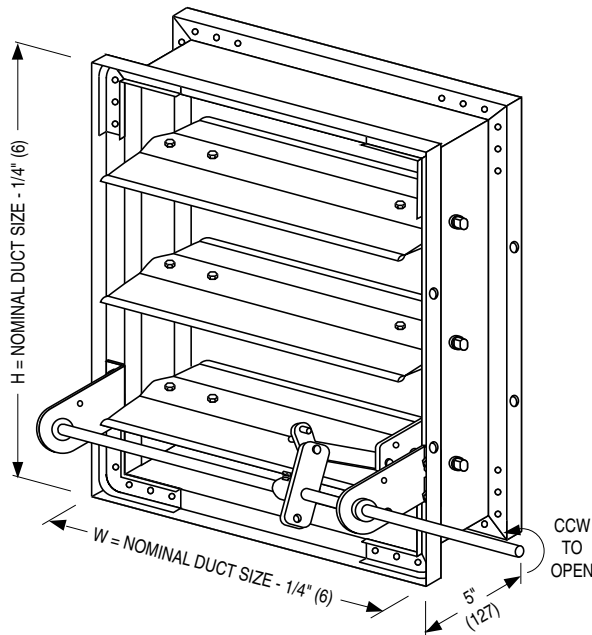

Wall Thickness	Minimum Sleeve Length
4 (102)	16 (406)
8 (203)	20 (508)
12 (305)	24 (610)
16 (406)	28 (711)

LEAKAGE CLASS/ELEVATED TEMPERATURE:

- I II @ 250°F

DYNAMIC VELOCITY/PRESSURE RATING:

24 2000 fpm @ 4" w.g.

ACTUATOR SELECTION:

- Electric Pneumatic

ACTUATOR LOCATION:

- External (std.) Internal (in the airstream)

ACTUATOR FAIL POSITION: Closed.

OPTIONS:

- MLS-300 Position indicator switch pack
- MLS-400 Electric Fire Sensor (Re-openable control system). Includes dual heat sensors (165°F and 250°F) and position indicator switch pack.

- QS1 Quick-set retaining angle (one side)
- QS2 Quick-set retaining angles (two sides)

Note: QS1 and QS2 are galvanized steel.

SCHEDULE TYPE:

PROJECT:

ENGINEER:

CONTRACTOR:

For installation instructions, see IOM-1220INST.
 Dimensions are in inches (mm).

DATE	B SERIES	SUPERSEDES	DRAWING NO.
10 - 14 - 24	1200	5 - 7 - 12	1220SS-3-1