



COMBINATION FIRE/SMOKE DAMPER
VERTICAL AIRFOIL BLADE
1 1/2 HOUR LABEL • ULTRA-LOW LEAKAGE
HIGH PERFORMANCE
MODEL: 1222VB (TYPE B SLEEVE ENCLOSURE)



FOR DUCTS UNDER 8" (203) IN HEIGHT AND 8" (203) OR MORE IN WIDTH

QUALIFICATIONS:

- **UL 555 & CAN/ULC-S112 CLASSIFIED DYNAMIC FIRE DAMPER** 1 1/2 hr. Label (File #'s R9492 & R19569).
- **UL 555S & CAN/ULC-S112.1 CLASSIFIED SMOKE DAMPER** Leakage Class I or II at 250°F elevated temperature (File # R9492).
- **Meets NFPA 80, 90A, 92A, 92B, 101 and 105 as well as IBC and NBC (Canada) Building Code requirements.**
- **California State Fire Marshal Listing No. 03230-0935:106.**
- **City of New York. MEA # 366-03-M.**
- **Maximum velocity: 2000 fpm @ 4" w.g.**

Model 1222VB (Vertical Blade) is a high performance combination fire/smoke damper that provides superior protection and versatility. The vertical blade configuration allows for the actuator to be mounted below the damper and is ideal for applications where bottom access is desired or where there isn't space for a side mounted actuator.

The 1220VB Series dampers are ideal for applications where building codes require both a fire damper for the protection of ductwork penetrations in walls that have a fire resistance rating of up to 2 hours and also require a leakage rated damper for operational smoke control in static or dynamic smoke management systems.

The 1220VB Series has been especially designed and tested to provide premium performance. It offers the lowest leakage class available and is qualified for installation with airflow in either direction. Airfoil blade design and elimination of blade sills provide a low pressure drop design.

Unique, inter-locking double skin blade design provides flame and smoke seal under fire conditions at temperatures up to 2000°F.

STANDARD SPECIFICATION:

- Frame:** 5" x 7/8" x 16 ga. (127 x 22 x 1.6) galvanized steel hat channel.
Blades: 14 ga. (2.0) equivalent galvanized steel formed airfoil on 5 1/2" (140) centers. Opposed action.
Linkage: Concealed in frame. 12 ga. (2.7) plated steel.
Bearings: 1/2" (13) dia. self-lubricating oilite bronze.
Axles: 1/2" (13) dia. plated steel double bolted to blades.
Jackshaft: 1/2" (13) dia. cadmium plated steel.
Jamb Seals: Stainless steel.

Heat Responsive Device (Controlled Closure):

250°F (121°C) standard. 165°F (74°C) and 212°F (100°C) available.
 ERL (Electric Resettable Link) is standard on all dampers with electric actuators.

Sizes (Duct W x H):

Velocity/ Pressure Rating	Elevated Temp. °F	Minimum	Maximum
		Single Section Vertical	Single Section Vertical
24	250	8" x 4" (203 x 102) (overall damper height is 8" [203]).	48" x 7 1/2" (1219 x 191)

Notes:

1. Duct sizes less than 8" (203) in width require a Type 'C' enclosure (Model 1223VB).
2. Multiple Section Assemblies are not permitted.

SLEEVE/ENCLOSURE SELECTION:

- 1222VB** Standard factory sleeve (caulked to UL requirements) 16" long x 20 ga. (406 x 1.0).
- 1222VB** Non-standard sleeve. Specify _____ length _____ ga. Available up to 36" (914) dependent upon wall thickness and 10 through 20 ga. (3.5 through 1.0).

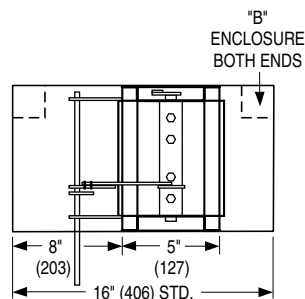
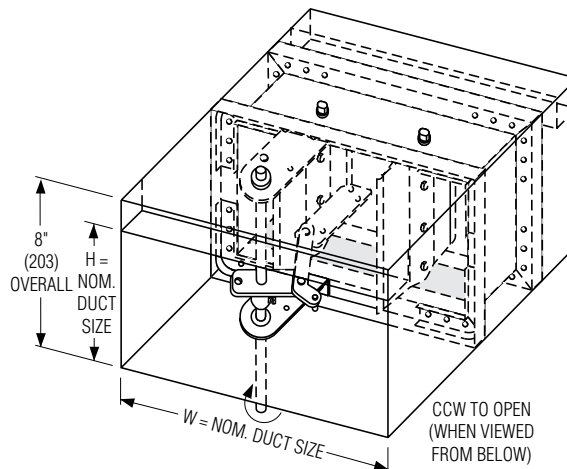

Wall Thickness	Minimum Sleeve Length
4 (102)	16 (406)
8 (203)	20 (508)
12 (305)	24 (610)
16 (406)	28 (711)

LEAKAGE CLASS/ELEVATED TEMPERATURE:

I II @ 250°F

DYNAMIC VELOCITY/PRESSURE RATING:

24 2000 fpm @ 4" w.g.

ACTUATOR SELECTION: Electric.

ACTUATOR LOCATION: External, bottom mount.

ACTUATOR FAIL POSITION: Closed.

OPTIONS:

- BS** Stainless steel bearings
- MLS-300** Position indicator switch pack
- MLS-400** Electric Fire Sensor (Re-openable control system). Includes dual heat sensors (165°F and 250°F) and position indicator switch pack.
- QS1** Quick-set retaining angle (one side)
- QS2** Quick-set retaining angles (two sides)

SCHEDULE TYPE:

PROJECT:

ENGINEER:

CONTRACTOR:

For installation instructions, see IOM-1220VBINST.
 Dimensions are in inches (mm).

DATE	B SERIES	SUPERSEDES	DRAWING NO.
10 - 16 - 24	1200	5 - 7 - 12	1220VB-2