



**OUT OF WALL COMBINATION FIRE/SMOKE DAMPER  
MODULATING • FOR THROUGH PENETRATIONS  
(DUCTED BOTH SIDES)  
1 1/2 HR. LABEL • ULTRA-LOW LEAKAGE  
MODEL: 1221-DOWM**



**QUALIFICATIONS:**

- **UL 555 & CAN/ULC-S112 CLASSIFIED DYNAMIC FIRE DAMPER**  
1 hr. Label (File # R9492).
- **UL 555S & CAN/ULC-S112.1 CLASSIFIED SMOKE DAMPER**  
Leakage Class I at 250°F elevated temperature (File # R9492).
- **Meets NFPA 80, 90A, 92, 101 and 105 as well as IBC and NBC (Canada) Building Code requirements.**
- **Maximum velocity: Up to 2000 fpm @ 4" w.g. (10 m/s @ 1 kPa).**

Model 1221-DOWM modulating combination fire/smoke damper is specially designed for "out of wall" (vertical mount) or "out of floor" (horizontal mount) through penetration applications (ductwork is connected to both sides) where the damper cannot be installed within the plane of the wall or floor.

The 1221-DOWM is ideal for retrofit applications where building codes require both a fire damper for the protection of ductwork penetrations in walls or floors that have a fire resistance rating of up to 2 hours and also require a leakage rated damper for operational smoke control in static or dynamic smoke management systems.

The 1221-DOWM offers premium performance with the lowest leakage class available and is qualified for installation with airflow in either direction. Unique, inter-locking double skin blade design eliminates combustible seals and provides flame and smoke seal under fire conditions at temperatures up to 2000°F.

**STANDARD CONSTRUCTION:**

- Frame:** 5" x 7/8" x 16 ga. (127 x 22 x 1.6) galvanized steel hat channel.
- Blades:** 14 ga. (2.0) equivalent galvanized steel formed airfoil on 5 1/2" (140) centers. Opposed action.
- Sleeve:** 21" x 20 ga. (533 x 1.0) galvanized steel standard.
- Insulation:** Intumescent thermal insulation on four sides.
- Linkage:** Concealed in frame. 12 ga. (2.7) plated steel.
- Bearings:** 1/2" (13) dia. self-lubricating oilite bronze.
- Axles:** 1/2" (13) dia. plated steel double bolted to blades.
- Jackshaft:** 1/2" (13) dia. cadmium plated steel.
- Jamb Seals:** Stainless steel.

**Heat Responsive Device (Controlled Closure):**

ERL (Electric Resettable Link) is standard on dampers with electric actuators: 250°F (121°C) standard. 165°F (74°C) and 212°F (100°C) available.

**Sizes (Damper W x H):**

Velocity/ Pressure Rating	Elevated Temp. °F	Minimum		Maximum	
		Single Section		Single Section	
		Vertical/Horizontal	Vertical	Horizontal	Horizontal
24	250	8" x 8" (203 x 203)	36" x 48" (914 x 1219)	32" x 48" (813 x 1219)	

**BASE MODEL SELECTION:**

- 1221-DOWM** Std. factory sleeve. (caulked to UL requirements). See above.
- 1221-DOWM** Non-standard sleeve. Specify \_\_\_\_\_ length \_\_\_\_ ga.

**LEAKAGE CLASS/ELEVATED TEMPERATURE:**

I @ 250°

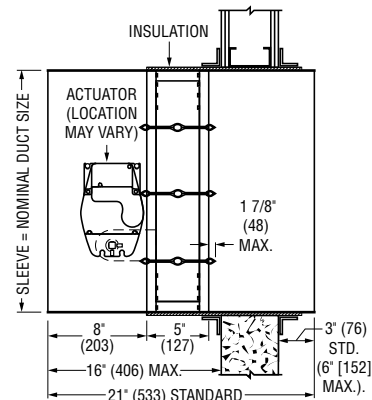
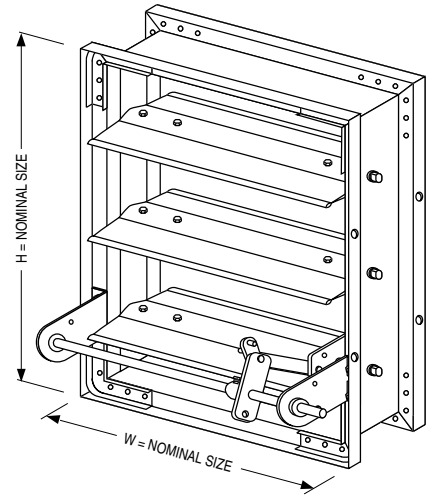

**NOTE:**  
STANDARD SLEEVE/DAMPER (FOR 4" [102] WALL) PROVIDES 1" (25) OFFSET FROM WALL FACE TO EDGE OF DAMPER FRAME. FOR THICKER WALLS OR TO OFFSET DAMPER FARTHER FROM WALL FACE (MAX. 8" [203]) LENGTHEN SLEEVE ACCORDINGLY.

**DYNAMIC VELOCITY/PRESSURE RATING:**

24 2000 fpm @ 4" w.g.

**ACTUATOR SELECTION:**

Electric

**ACTUATOR LOCATION:**

- External**  **Internal** (in the airstream)

**ACTUATOR FAIL POSITION:**  **CL** Closed

**OPTIONS:**

- BS** Stainless steel bearings
- MLS-300** Position indicator switch pack
- QS2** Quick-set retaining angles (pair)
- TDF1** TDF Flange (one end) } (20 ga.
- TDF2** TDF Flange (both ends) } sleeves only

<b>SCHEDULE TYPE:</b>	For installation instructions, see IOM-1221DOWINST.			
<b>PROJECT:</b>	Dimensions are in inches (mm).			
<b>ENGINEER:</b>	<b>DATE</b>	<b>B SERIES</b>	<b>SUPERSEDES</b>	<b>DRAWING NO.</b>
<b>CONTRACTOR:</b>	11 - 15 - 24	1200	10 - 22 - 24	1221-DOWM