



**COMBINATION FIRE/SMOKE DAMPER
FOR GRILLES • HIGH PERFORMANCE
AIRFOIL BLADE • 1 1/2 HR. LABEL
VERTICAL OR HORIZONTAL MOUNT
MODEL: 1221G**



QUALIFICATIONS:

- **UL 555 & CAN/ULC-S112 CLASSIFIED DYNAMIC FIRE DAMPER** 1 1/2 hr. Label (File # R9492).
- **UL 555S & CAN/ULC-S112.1 CLASSIFIED SMOKE DAMPER** Leakage Class I or II at 250°F or 350°F elevated temperature (File # R9492).
- **Meets NFPA 80, 90A, 92, 101 and 105 as well as IBC and NBC (Canada) Building Code requirements.**
- **City of New York. MEA # 366-03-M.**
- **California State Fire Marshal: Fire Damper Listing No. 3225-0935:0106.**
- **Maximum velocity: 2000 fpm @ 4" w.g. (10 m/s @ 1 kPa).**

Model 1221G is a high performance combination fire/smoke damper specifically designed for supply or return ducts that terminate at a grille. The special factory sleeve with unique 3/4" (19) grille mounting flanges simplifies installation, saves on field labor and eliminates the requirements for unsightly front retaining angles which commonly protrude from behind the grille. Steel grille with correctly located countersunk screwholes is available from Nailor and installs over and completely hides the mounting flanges. The standard damper offset in the sleeve accommodates a single or double deflection supply air grille, single deflection supply air register or a return air grille or register.

The 1221G is ideal for applications where building codes require both a fire damper for the protection of ductwork penetrations in walls or floors that have a fire resistance rating of up to 2 hours and also require a leakage rated damper for operational smoke control in static or dynamic smoke management systems.

The 1221G offers premium performance with the lowest leakage class available and a low pressure drop well suited to the majority of commercial applications. Unique, inter-locking double skin blade design eliminates combustible seals and provides flame and smoke seal under fire conditions at temperatures up to 2000°F.

STANDARD CONSTRUCTION:

- Frame:** 5" x 7/8" x 16 ga. (127 x 22 x 1.6) galvanized steel hat channel.
Blades: 14 ga. (2.0) equivalent galvanized steel formed airfoil on 5 1/2" (140) centers. Opposed action.
Sleeve: 16" x 20 ga. (406 x 1.0) galvanized steel with 3/4" (19) wide grille mounting flanges
Linkage: Concealed in frame. 12 ga. (2.7) plated steel.
Bearings: 1/2" (13) dia. self-lubricating oilite bronze.
Axles: 1/2" (13) dia. plated steel double bolted to blades.
Jackshaft: 1/2" (13) dia. cadmium plated steel.
Jamb Seals: Stainless steel.

Heat Responsive Device (Controlled Closure):

ERL (Electric Resettable Link) is standard on dampers with electric actuators: 250°F (121°C) std., 165°F (74°C), 212°F (100°C) and 350°F (176°C) available. PRL (Pneumatic Replaceable Link) is standard on dampers with pneumatic actuators: 212°F (100°C) standard. 165°F (74°C) and 280°F (138°C) available.

Sizes (Duct W x H):

Velocity/ Pressure Rating	Elevated Temp. °F	Minimum	Maximum
		Single Section Vertical/Horizontal	Single Section Vert./Horiz.
24	250/350	8" x 8" (203 x 203), 8" x 6" (203 x 152) with low profile frame (max. size 18" x 6" [457 x 152]).	24" x 24" (610 x 610)

Note: With S = 4" (102), a minimum 6 1/2" (165) wall thickness is required for this installation. Centerline of damper must be within plane of wall. Reducing the offset reduces the minimum wall thickness by an equal amount, but also reduces clearance for the grille.

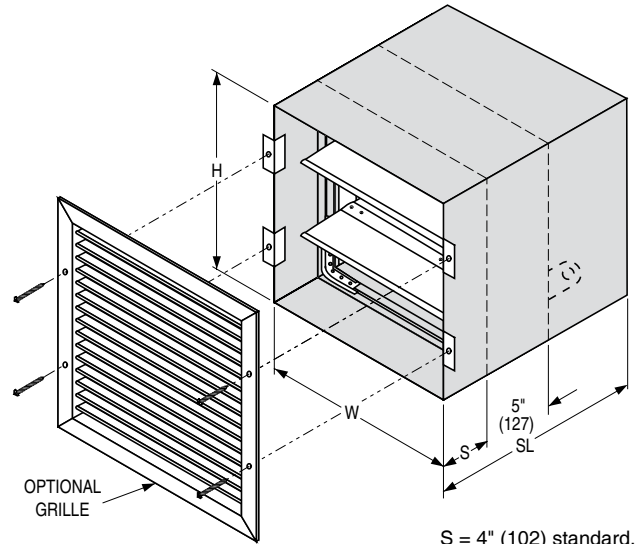

S = 4" (102) standard.

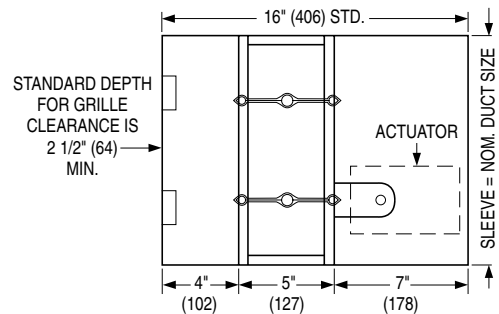

BASE MODEL SELECTION:

- 1221G** Standard factory sleeve (caulked to UL requirements) see above.
- 1221G** Non-standard sleeve: Specify ___ length ___ ga. Non-standard damper position: S = ___.

LEAKAGE CLASS/ELEVATED TEMPERATURE:

- I II @ 250°F (Standard)
- I II @ 350°F (Optional)

DYNAMIC VELOCITY/PRESSURE RATING:

24 2000 fpm @ 4" w.g.

ACTUATOR SELECTION:

- Electric** **Pneumatic**

ACTUATOR LOCATION :

- External** (std.) **Internal** (in the airstream)

ACTUATOR FAIL POSITION: Closed.

OPTIONS:

- BS** Stainless steel bearings
- MLS-300** Position indicator switch pack
- MLS-400** Electric Fire Sensor (Re-openable control system). Includes dual heat sensors (165°F and 250°F or 350°F) and position indicator switch pack.
- QS1** Quick-set retaining angle (one side)
- TDF1** Flange (one end; for 20 ga. sleeve only)

For installation instructions, see IOM-FSDGTINST
Dimensions are in inches (mm).

SCHEDULE TYPE:				
PROJECT:				
ENGINEER:	DATE	B SERIES	SUPERSEDES	DRAWING NO.
CONTRACTOR:	10 - 24 - 24	1200	6 - 16 - 16	1221G