



**COMBINATION FIRE/SMOKE DAMPER
FOR GRILLES**
1 1/2 HR. LABEL • LEAKAGE CLASS I OR II
VERTICAL OR HORIZONTAL MOUNT
MODEL: 1271G



QUALIFICATIONS:

- UL 555 & CAN/ULC-S112 CLASSIFIED DYNAMIC FIRE DAMPER 1 1/2 hr. Label (File #'s R9492 and R19569).
- UL 555S & CAN/ULC-S112.1 CLASSIFIED SMOKE DAMPER Leakage Class I or II at 250°F or 350°F elevated temperature (File # R9492)
- Meets NFPA 80, 90A, 92, 101 and 105.
- Maximum velocity: 2000 fpm @ 4" w.g. (10 m/s @ 1 kPa).

Model 1271G combination fire/smoke damper is specifically designed for supply or return ducts that terminate at a grille. The special factory sleeve with unique 3/4" (19) grille mounting flanges simplifies installation, saves on field labor and eliminates the requirements for unsightly front retaining angles which commonly protrude from behind the grill. Steel grille with correctly located countersunk screw holes is available from Nailor and installs over and completely hides the mounting flanges. The standard damper offset in the sleeve accommodates a single or double deflection supply air grille, single deflection supply air register or a return air grille or register.

The 1271G is ideal for applications where building codes require both a fire damper for the protection of ductwork penetrations in walls or floors that have a fire resistance rating of up to 2 hours and also require a leakage rated damper for operational smoke control in static or dynamic smoke management systems.

The 1271G has been especially designed and tested to offer a rugged cost effective damper well suited to the majority of commercial applications.

STANDARD CONSTRUCTION:

- Frame:** 5" x 7/8" x 16 ga. (127 x 22 x 1.6) galvanized steel hat channel.
- Blades:** 6" (152) wide on 5 1/2" (140) centers. 16 ga. (1.6) galvanized steel vee groove or double-skin design.
- Sleeve:** 16" x 20 ga. (406 x 1.0) galvanized steel with 3/4" (19) wide grille mounting tabs.
- Linkage:** Concealed in frame. 12 ga. (2.7) plated steel.
- Bearings:** 1/2" (13) dia. self-lubricating oilite bronze.
- Axles:** 1/2" (13) dia. plated steel double bolted to blades.
- Jackshaft:** 1/2" (13) dia. cadmium plated steel.
- Jamb Seals:** Stainless steel.
- Blade Seals:** Stainless steel on vee groove blade.

Heat Responsive Device (Controlled Closure):

ERL (Electric Resettable Link) is standard on dampers with electric actuators:
250°F (121°C) standard. 165°F (74°C), 212°F (100°C) and 350°F (177°C) available.

PRL (Pneumatic Replaceable Link) is standard on dampers with pneumatic actuators: 212°F (100°C) standard. 165°F (74°C) and 280°F (138°C) available.

Model 1271G Sizes (Duct W x H):

Velocity/ Pressure Rating	Elevated Temp. °F	Minimum	Maximum
		Single Section Vertical/Horizontal	Single Section Vertical/Horizontal
24	250/350	8" x 8" (203 x 203)	24" x 24" (610 x 610)

Note: With S = 4" (102), a minimum 6 1/2" (165) wall thickness is required for this installation. Centerline of damper must be within plane of wall. Reducing the offset reduces the minimum wall thickness by an equal amount, but also reduces clearance for the grille.

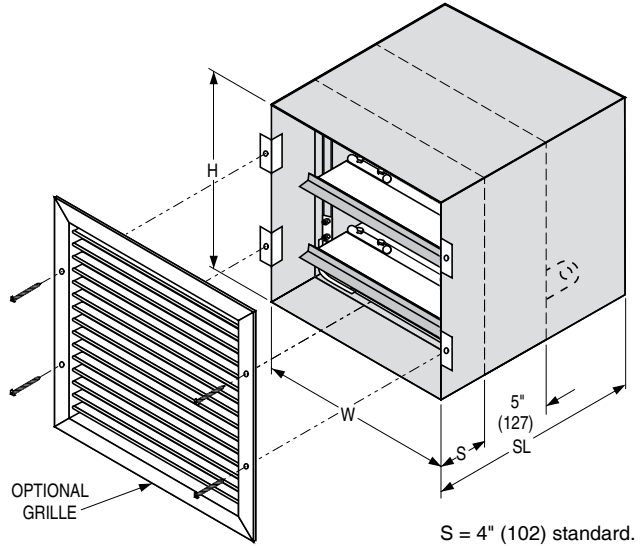

S = 4" (102) standard.

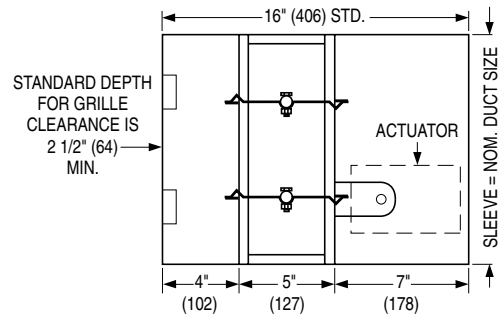

BASE MODEL SELECTION:

- 1271G Standard factory sleeve (caulked to UL requirements) 16" (406) see above.
- 1271G Non-standard sleeve: Specify ___ length ___ ga. Non-standard damper position: S = ____.

LEAKAGE CLASS / ELEVATED TEMPERATURE:

- I II @ 250°F (Standard)
- I II @ 350°F (Optional)

ACTUATOR SELECTION:

- Electric Pneumatic Specify model _____.

ACTUATOR LOCATION :

- External (std.) Internal (in the airstream)

ACTUATOR FAIL POSITION: Closed.

OPTIONS:

- BS Stainless steel bearings
- MLS-300 Position indicator switch pack
- MLS-400 Electric Fire Sensor (Re-openable control system). Includes dual heat sensors (165°F and 250°F or 350°F) and position indicator switch pack.
- QS1 Quick-set retaining angle (one side)
- TDF1 Flange (one end)

SCHEDULE TYPE:

PROJECT:

ENGINEER:

CONTRACTOR:

For installation instructions, see IOM-FSDGTINST
Dimensions are in inches (mm).

DATE	B SERIES	SUPERSEDES	DRAWING NO.
10 - 16 - 24	1200	6 - 16 - 16	1271G