



SMOKE DAMPER

HIGH PERFORMANCE • AIRFOIL BLADE
 LOW LEAKAGE • LOW PRESSURE DROP
MODEL: 1280 WITH EAF OPTION



QUALIFICATIONS:

- **UL 555S CLASSIFIED SMOKE DAMPER (File # R9492)**
Leakage Class I or II at 250°F or 350°F elevated temperature.
- Meets NFPA 90A, 92, 101 and 105 as well as IBC and NBC (Canada) Building Code requirements.
- City of New York. MEA # 366-03-M.
- California State Fire Marshal: Fire Damper Listing No. 03230-0935:0107.
- Maximum velocity: 2000 fpm @ 4" w.g. (10 m/s @ 1 kPa).

Model Series 1280 Dampers are Nailor's premium choice for applications where The 1280 Series dampers are Nailor's premium choice for applications where building codes require a leakage rated (smoke) damper as part of a static smoke control or dynamic smoke management system.

The 1280 Series features a smoothly contoured extruded aluminum airfoil blade and compression type seals that have been especially designed to offer the lowest leakage class available. Together with out of airstream linkage, the design provides an ultra-low pressure drop and minimizes unwanted turbulence and noise generation. Qualified for vertical or horizontal installation with airflow in either direction. Option EAF provides a heavy duty extruded aluminum hat channel frame with hat mounting flanges.

STANDARD CONSTRUCTION (WITH OPTION EAF):

- Frame:** Extruded aluminum frame.
5" x 7/8" x 1/8" (127 x 22 x 3.2) 6063-T5 extruded aluminum.
- Blades:** Airfoil type 6063-T5 extruded aluminum on 5 1/2" (140) centers. Parallel action.
- Linkage:** Concealed in frame. 12 ga. (2.7) plated steel.
- Bearings:** 1/2" (13) dia. self-lubricating oilite bronze.
- Axles:** 1/2" (13) dia. plated steel double bolted to blades.
- Jackshaft:** 1/2" (13) dia. plated steel.
- Jamb Seals:** Cambered stainless steel.
- Blade Seals:** Silicone.

Sizes (Duct W x H):

Velocity/ Pressure Rating	Elevated Temp. °F	Minimum		Maximum	
		Single Section	Single Section	Multiple Section	
		Vertical/Horizontal	Vertical/Horizontal	Vertical/Horizontal	Vertical/Horizontal
24	250/350	8" x 8" (203 x 203)	36" x 48" (914 x 1219)	144" x 96" (3658 x 2438), 288" x 48" (7315 x 1219) or 72" x 144" (1829 x 3658).	

BASE MODEL SELECTION:

- 1280 w/ EAF OPTION With actuator side mounting plate.

LEAKAGE CLASS / ELEVATED TEMPERATURE:

- I II @ 250°F (Standard)
 I II @ 350°F (Optional)

DYNAMIC VELOCITY/PRESSURE RATING:

- 24 2000 fpm @ 4" w.g. (Standard)

ACTUATOR SELECTION:

- Electric Pneumatic Specify model _____ .

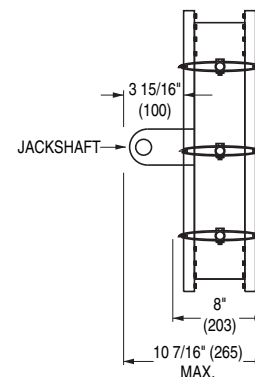
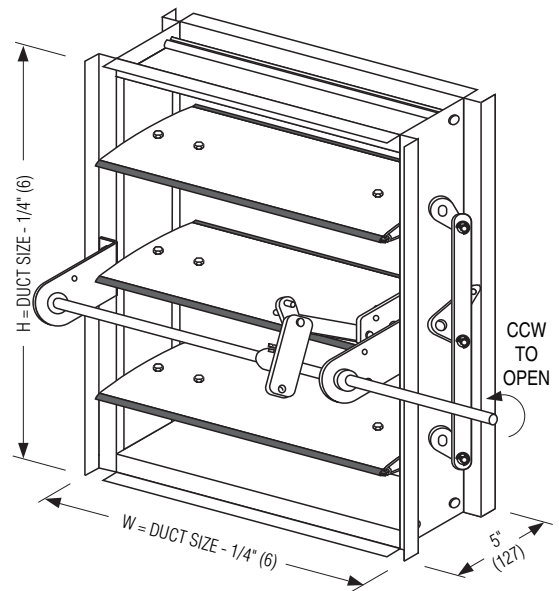

ACTUATOR LOCATION:

- External (std.) Internal (in the airstream)

ACTUATOR FAIL POSITION: Closed

OPTIONS:

- BS Stainless steel bearings
 MLS-300 Position indicator switch package
 Special features _____ .

SCHEDULE TYPE:

PROJECT:

ENGINEER:

CONTRACTOR:

For installation instructions, see IOM-SDINST.
 Dimensions are in inches (mm).

DATE	B SERIES	SUPERSEDES	DRAWING NO.
4 - 28 - 14	1280	1 - 1 - 12	1280-1A