



SMOKE DAMPER
HIGH PERFORMANCE • AIRFOIL BLADE
ROUND DUCT CONNECTION
MODEL: 1283 (TYPE C SLEEVE ENCLOSURE)



QUALIFICATIONS:

- **UL 555S & CAN/ULC-S112.1 CLASSIFIED SMOKE DAMPER (File # R9492) Leakage Class I or II at 250°F or 350°F elevated temperature.**
- **Meets NFPA 90A, 92, 101 and 105 as well as IBC and NBC (Canada) Building Code requirements.**
- **City of New York. MEA # 366-03-M.**
- **California State Fire Marshal: Fire Damper Listing No. 03230-0935:0107.**
- **Maximum velocity: 2000 fpm @ 4" w.g. (10 m/s @ 1 kPa).**

Model Series 1280 dampers are Nailor's premium choice for applications where building codes require a leakage rated (smoke) damper as part of a static smoke control or dynamic smoke management system.

The 1280 Series features a smoothly contoured extruded aluminum airfoil blade and compression type seals that have been especially designed to offer the lowest leakage class available. Together with out of airstream linkage, the design provides an ultra-low pressure drop and minimizes unwanted turbulence and noise generation. Qualified for vertical or horizontal installation with airflow in either direction.

STANDARD CONSTRUCTION:

- Frame:** 5" x 7/8" x 16 ga. (127 x 22 x 1.6) galv. steel hat channel.
- Blades:** Airfoil type 6063-T5 extruded aluminum on 5 1/2" (140) centers. Parallel action.
- Linkage:** Concealed in frame. 12 ga. (2.7) plated steel.
- Bearings:** 1/2" (13) dia. self-lubricating oilite bronze.
- Axles:** 1/2" (13) dia. plated steel double bolted to blades.
- Jackshaft:** 1/2" (13) dia. plated steel.
- Jamb Seals:** Cambered stainless steel.
- Blade Seals:** Silicone.

Round Duct Connection Sizes (Duct Dia.):

Velocity/ Pressure Rating	Elevated Temp. °F	Minimum			Maximum		
		Single Section		Single Section	Multiple Section		
		Vertical/Horizontal	Vertical/Horizontal	Vertical/Horizontal	Vertical/Horizontal	Vertical/Horizontal	
24	250/350	4" (102) dia. Overall damper size is 8" x 8" (203 x 203) min.		34" (864) dia.	94" (2388) dia.		

Notes: Duct heights less than 8" (203) require a Type 'B' sleeve enclosure (Model 1282). Duct sizes less than 8" (203) in width require a Type 'C' enclosure (Model 1283).

BASE MODEL SELECTION:

- 1283** Standard factory sleeve (caulked to UL req.) 16" long x 20 ga. (406 x 1.0).
- 1283** Non-standard sleeve. Specify _____ length _____ ga. Available up to 36" (914) dependent upon wall thickness and 10 through 20 ga. (3.5 through 1.0).

LEAKAGE CLASS / ELEVATED TEMPERATURE:

- I II @ 250°F (Standard)
- I II @ 350°F (Optional)

DYNAMIC VELOCITY/PRESSURE RATING:

- 24** 2000 fpm @ 4" w.g. (Standard)

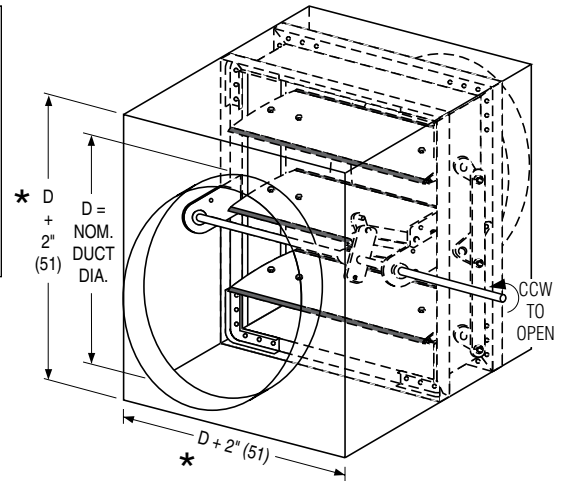

* or 8" (203) min.

STYLE CR : FOR ROUND DUCT

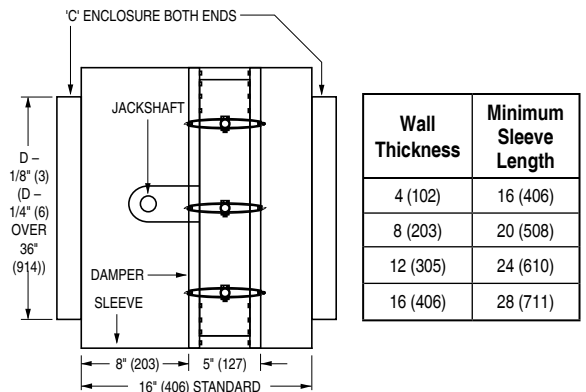

ACTUATOR SELECTION:

- Electric** **Pneumatic** Specify model _____ .

ACTUATOR LOCATION:

- External** (std.) **Internal** (in the airstream)

ACTUATOR FAIL POSITION: Closed

OPTIONS:

- BS** Stainless steel bearings
- MLS-300** Position indicator switch package
- DSDL** Low Flow Smoke Detector
- DSDN** No Flow Smoke Detector
- Special features** _____ .

SCHEDULE TYPE:

PROJECT:

ENGINEER:

CONTRACTOR:

For installation instructions, see IOM-SDINST.
 Dimensions are in inches (mm).

DATE	B SERIES	SUPERSEDES	DRAWING NO.
10 - 4 - 24	1280	4 - 28 - 14	1280-3