



BACKDRAFT DAMPER
 HIGH PERFORMANCE • HEAVY DUTY
 EXTRUDED ALUMINUM BLADES & FRAME
MODEL: 1380

Model 1380 is a high performance gravity operated backdraft damper for use in medium to heavy duty commercial and light industrial HVAC applications. Backdraft dampers are used in systems to pass airflow in one direction and to prevent airflow in the opposite direction.

Corrosion resistant extruded aluminum construction highlights the model's features which include a reinforced mitered corner frame that resists racking, and aerodynamic blades that overlap the jambs for maximum weather protection. Extruded PVC blade seals provide quiet closure as well as extra weather protection. Blade linkage is mounted out of view on the rear of the blades and provides smooth operation at system velocities of up to 2500 fpm.

STANDARD CONSTRUCTION:

- Frame:** 2 1/4" (57) duct mount type, .125" (3.2) nominal wall thickness type 6063-T5 extruded aluminum. Corners are mitered.
- Blades:** .070" (1.8) nominal wall thickness type 6063-T5 extruded aluminum on 5 1/2" (140) centers.
- Linkage:** Center mounted on rear of blades.
- Bearings:** Synthetic type.
- Blade Seals:** Extruded PVC.
- Finish:** Mill.
- Minimum Size:** 6" x 6" (152 x 152).
- Maximum Size:** Single Section: 48" x 72" (1219 x 1829).
Multiple section: Unlimited.
- Maximum Temperature:** 200°F (93°C).
- Maximum Back Pressure:** 4 to 16 in. w.g. (see page 2).
- Max. System Velocity:** 3000 fpm (3500 fpm maximum spot velocity).

MOUNTING:

- VM Vertical mount (standard)
- HMU Horizontal mount (airflow up only)

OPTIONS:

- PRC Pressure Relief Controller
- FF Front flange
- FFB Front flange with bolt holes
- FR Rear flange
- FRB Rear flange with bolt holes
- GBS Bird screen, galvanized
- AIS Insect screen, aluminum
- Special features: _____ .

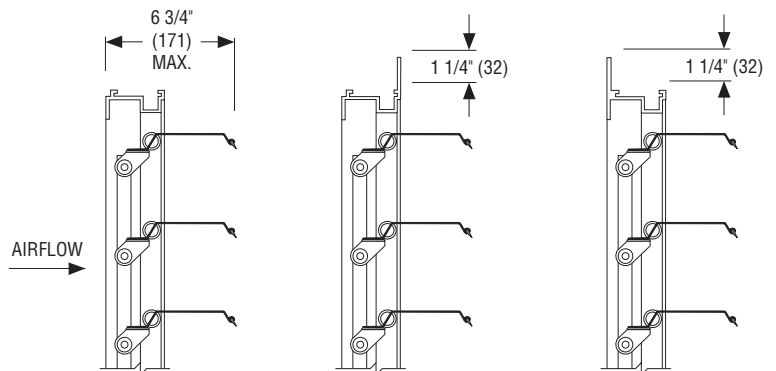
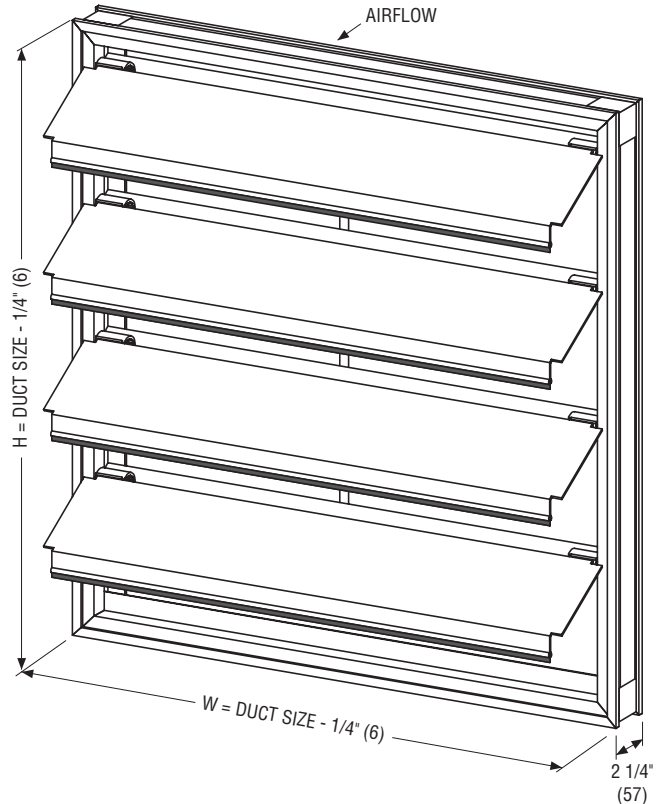

**Channel Frame
(Duct Mount)
(Standard CF)**

**Front Flange
(on discharge side)
(Option FF)**

**Rear Flange
(on intake side)
(Option FR)**

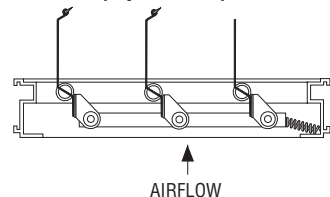

**Horizontal Mount – Airflow up only (Option HMU)
(Available on all frame styles)**

SCHEDULE TYPE:	
PROJECT:	
ENGINEER:	
CONTRACTOR:	

Page 1 of 2 Dimensions are in inches (mm).			
DATE	B SERIES	SUPERSEDES	DRAWING NO.
6 - 15 - 26	1300	12 - 19 - 25	1380



BACKDRAFT DAMPER
 HIGH PERFORMANCE • HEAVY DUTY
 EXTRUDED ALUMINUM BLADES & FRAME
PERFORMANCE DATA
MODEL: 1380

PERFORMANCE LIMITATIONS AND LEAKAGE DATA:

Damper Width	Maximum Back Pressure	Maximum System Velocity	Operational Data		Leakage*	
			Blades Begin Opening	Blades Fully Open	% of Max.	CFM per Sq. Ft.
48" (1219)	4.0" w.g.	3000 fpm	.08" w.g. (20 Pa)	.30" w.g. (75 Pa)	0.60	15
36" (914)	8.0" w.g.	3000 fpm			0.60	15
24" (610)	12.0" w.g.	3000 fpm			0.72	18
12" (305)	16.0" w.g.	3000 fpm			1.00	25

Pressure and velocity limitations shown are guidelines for design purposes. Although ratings are on the conservative side, contact Nailor for requirements beyond limitations shown.

*Leakage data is based upon a pressure differential of 1 in. w.g., tested in accordance with AMCA Standard 500-D.

PRESSURE DROP: SIZE: 36" x 36" (914 x 914)

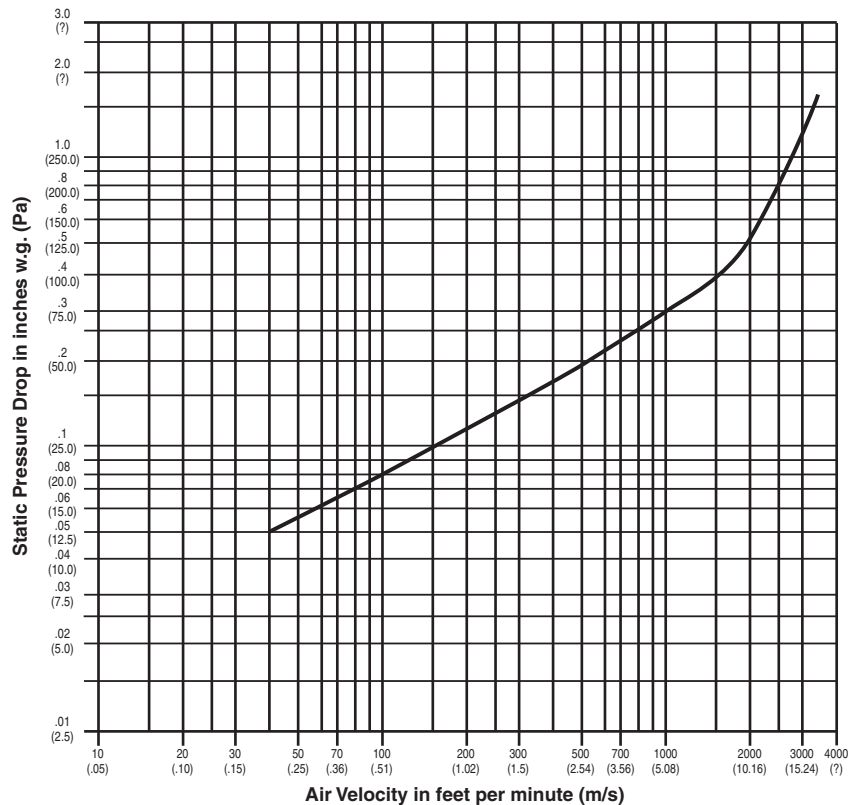

Tested per AMCA Standard 500-D using test set-up Figure 5.5, plenum mounted.

OPTIONAL PRC (PRESSURE RELIEF CONTROLLER)

The PRC option enables the backdraft damper to be used for static pressure relief control. The maximum relief pressure is damper size dependent (see table below). The PRC is field set and field adjustable. Minimum damper size is 12" x 12" (305 x 305). One per damper section is required. Maximum recommended static pressure set limitations are as follows:

Damper Area ft ² (m ²)	Max. Set Pressure in. w.g. (Pa)
4.0 (.37)	1.10 (273)
6.0 (.56)	0.75 (186)
8.0 (.74)	0.55 (137)
9.0 (.84)	0.50 (124)
10.0 (.93)	0.45 (112)
12.0 (1.12)	0.37 (92)
14.0 (1.30)	0.32 (80)
17.0 (1.58)	0.25 (62)
20.0 (1.86)	0.15 (37)
24.0 (2.23)	0.125 (31)

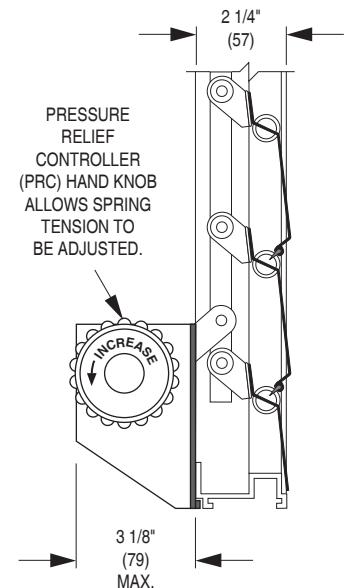

SCHEDULE TYPE:

PROJECT:

ENGINEER:

CONTRACTOR:

Page 2 of 2
 Dimensions are in inches (mm).

DATE	B SERIES	SUPERSEDES	DRAWING NO.
6 - 15 - 26	1300	12 - 19 - 25	1380