



EXTRUDED ALUMINUM LOUVERED PENTHOUSES BOX (POST) CORNERS MODEL: 1600PHB

Nailor Model 1600PHB Extruded Aluminum Box Corner Penthouses offer an aesthetically appealing option of concealing mechanical rooftop equipment or protecting air intake/relief openings from outside elements. A variety of finishes, construction options and accessories are available to meet almost any requirement.

STANDARD CONSTRUCTION:

BLADES: Type 6063-T5 extruded aluminum, .080" (2.03) nominal wall thickness, see note 1 below.

BLADE SUPPORT ANGLES: 1 1/2" x 2" (38 x 51) on max. 60" (1524) centers.

ROOF: Alum. sheet .080" (2.03) nom. wall thickness.

ROOF SUPPORT ANGLES: 1 1/2" x 2" x 1/4" (38 x 51 x 6) (as required by size of unit).

BIRD SCREEN: 3/4" x .051 (19 x 1.3) expanded, flattened alum. bird screen.

OPTIONS:

- BSSS** Type 304 S.S. Bird Screen.
- BSN** No Bird Screen.
- ISA** Aluminum Insect Screen.
- ISSS** Type 304 S.S. Insect Screen.
- IR1** 1" (25) Fiberglass Roof Insulation.
- BIT** Bitumastic Roof Undercoating.
- Other: _____.

OPTIONAL FINISHES:

- PC3** Powder Coat AAMA 2603. Color: _____.
- PC4** High Performance Powder Coat AAMA 2604 (Equivalent to 50% Kynar®). Color: _____.
- PC5** Fluoropolymer Powder Coat AAMA 2605 (Equivalent to 70% Kynar®). Color: _____.
- PCC** Prime Coat.
- AN04** Clear Anodized 204-R1.
- AN15** Clear Anodized 215-R1.

Color Anodized:

- ANLB** Light Bronze. **ANMB** Medium Bronze.
- ANDB** Dark Bronze. **ANBK** Black.

NOTE:

1. The following louver model styles may be used: 1604J, 1604Y, 1604KD, 1604D, 1604DD, 1604DHP, 1605WD, 1606WD, 1606J, 1606KD, 1606D, 1606DHP and 1606DD.

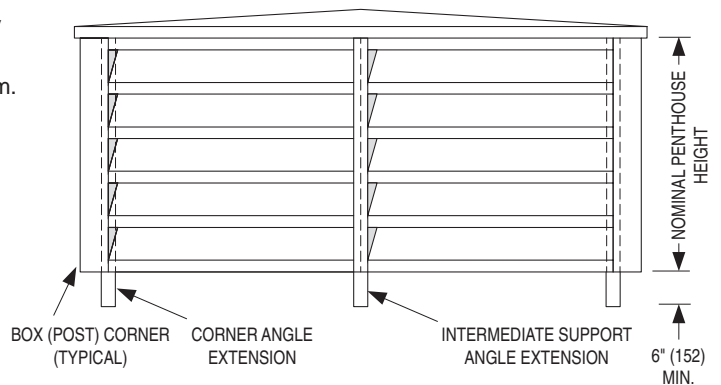
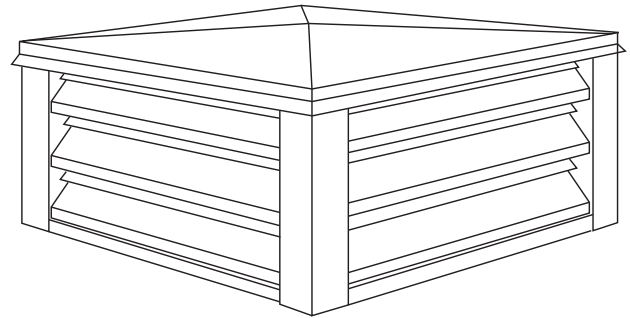
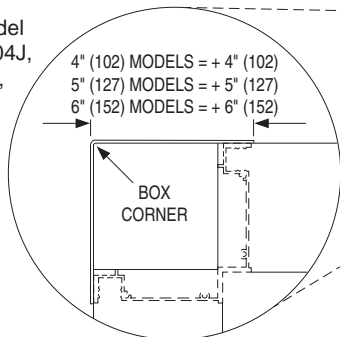

FRONT ELEVATION VIEW

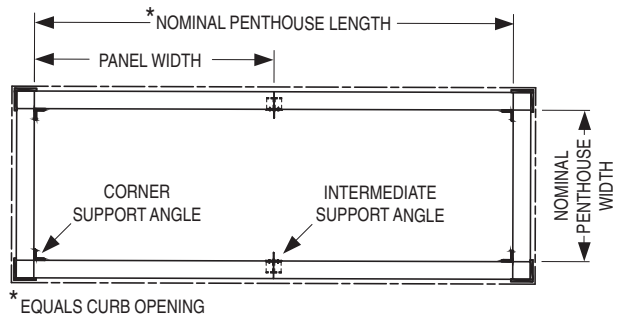

PLAN VIEW

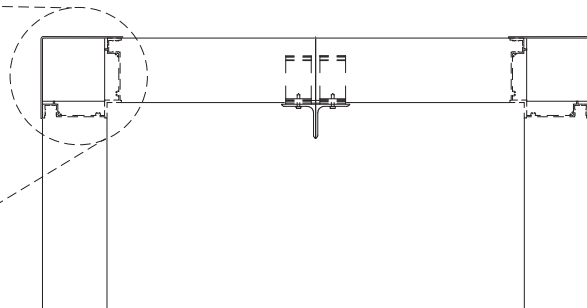

BOX (POST) CORNER DETAIL

Dimensions are in inches (mm).

SCHEDULE TYPE:				
PROJECT:				
ENGINEER:				
CONTRACTOR:				
DATE	B SERIES	SUPERSEDES	DRAWING NO.	
10 - 19 - 15	1600	5 - 11 - 15	1600PHB	