



EXTRUDED ALUMINUM ADJUSTABLE LOUVER
6" (152) DEEP • DRAINABLE BLADE
MODEL: 1606AD

Model 1606AD adjustable, drainable blade type louver combines superior weather protection and architecturally pleasing aesthetics with airflow control including tight shut-off. Suitable for use in exhaust and low to medium velocity intake applications, the design features a drainable blade with rain gutters that divert collected water down concealed side downspouts and out the sill. The blades can be operated manually or with an actuator to provide tight shut-off when desired. Blades are reinforced with full length integral bosses for superior strength and the design exhibits low pressure drop characteristics throughout the airflow range. Model 1606AD provides adjustable flexibility as well as maximum protection against the elements.

STANDARD CONSTRUCTION:

- FRAME:** 6" (152) deep, Type 6063-T6 extruded aluminum, .080" (2.03) nominal wall thickness. Integral downspouts and caulking slot provided.
- BLADES:** Type 6063-T6 extruded aluminum, .080" (2.03) nominal wall thickness, with reinforcing bosses.
- BLADE SPACING:** Approx. 6" (152) on centers, at 37 1/2° angle (fully open).
- JAMB SEALS:** Compression type cambered metal.
- AXLES:** 1/2" (13) dia. plated steel.
- BEARINGS:** 1/2" (13) dia. Celcon®.
- LINKAGE:** Plated steel. Concealed in frame.
- SCREEN:** 3/4" x .051 (19 x 1.3) expanded, flattened aluminum bird screen in removable frame, inside (rear) mount (adds approximately 3/8" [10] to louver depth).
- ACTUATOR:** Hand locking louver quadrant.
- FINISH:** Mill.
- MINIMUM SIZE:** 12" W x 12" H (305 x 305).
- MAX. SINGLE SECTION SIZE:** 48" W x 96" H (1219 x 2438) (With Blade and/or Jamb Seals). 60" W x 120" H (1524 x 3048) (Without Seals). Larger sizes will be manufactured in sections with visible mullion side frame (downspouts are concealed) for field assembly.

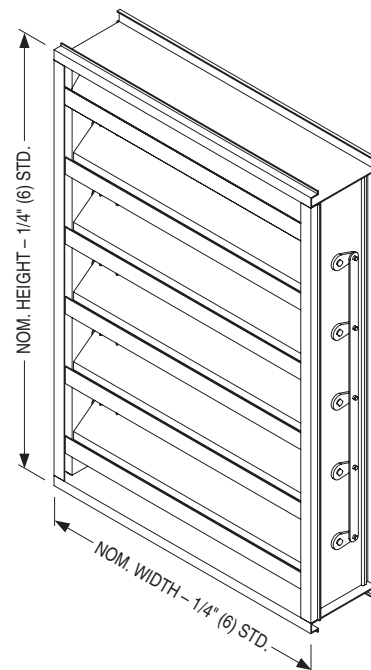

OPTIONS:

- FL** Flanged Frame.
- BPV** PVC Blade Seals.
- JSN** No Jamb Seals.
- BSSS** Type 304 S. S. Bird Screen.
- BSN** No Bird Screen.
- ISA** Aluminum Insect Screen.
- ISSS** Type 304 S. S. Insect Screen.
- WE** Welded Construction.
- ESI** Extended Sill.
- FR1** 1" (25) Filter Rack.
- FR2** 2" (51) Filter Rack.
- PAC** Perimeter Anchor Clips.
- ACT** Electric or Pneumatic Actuator. Specify: _____.
- Other:** _____.

OPTIONAL FINISHES:

- PC3** Powder Coat AAMA 2603. Color: _____.
 - PC4** High Performance Powder Coat AAMA 2604 (Equivalent to 50% Kynar®). Color: _____.
 - PC5** Fluoropolymer Powder Coat AAMA 2605 (Equivalent to 70% Kynar®). Color: _____.
 - PCC** Prime Coat.
 - AN04** Clear Anodized 204-R1.
 - AN15** Clear Anodized 215-R1.
- Color Anodized:
- ANLB** Light Bronze. **ANMB** Medium Bronze.
 - ANDB** Dark Bronze. **ANBK** Black.

OPTIONAL W x H SIZING (1/4" [6.5] Undersize standard):

- U00** Exact Size.
- U38** Undersize 3/8" (9.5).
- U50** Undersize 1/2" (12.7).

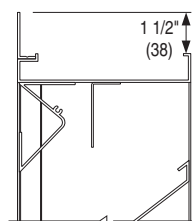

FLANGED FRAME (FL)
(OPTIONAL)

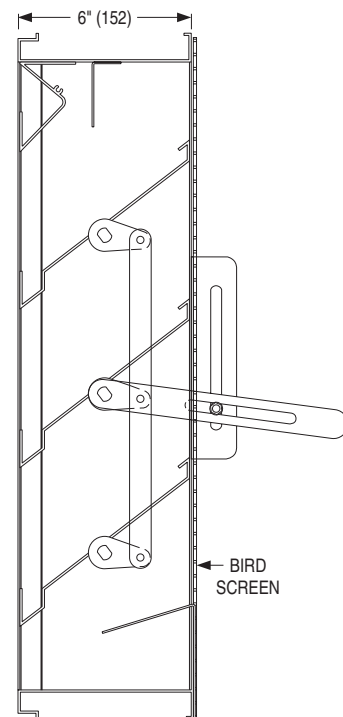

SCHEDULE TYPE:
PROJECT:
ENGINEER:
CONTRACTOR:

Page 1 of 2
 Dimensions are in inches (mm).

DATE	B SERIES	SUPERSEDES	DRAWING NO.
5 - 10 - 22	1600	5 - 30 - 19	1606AD



**EXTRUDED ALUMINUM ADJUSTABLE LOUVER
6" (152) DEEP • DRAINABLE BLADE
PERFORMANCE DATA
MODEL: 1606AD**

FREE AREA in Square Feet and Square Meters

		Width in Inches and Meters									
		12	18	24	30	36	42	48	54	60	
Height in Inches and Meters	12	0.28	0.45	0.62	0.79	0.96	1.13	1.30	1.47	1.65	
	0.3	0.03	0.04	0.06	0.07	0.09	0.11	0.12	0.14	0.15	
	18	0.54	0.87	1.20	1.54	1.87	2.20	2.53	2.86	3.19	
	0.46	0.05	0.08	0.11	0.14	0.17	0.20	0.23	0.27	0.30	
	24	0.78	1.25	1.73	2.20	2.67	3.15	3.62	4.10	4.57	
	0.61	0.07	0.12	0.16	0.20	0.25	0.29	0.34	0.38	0.42	
	30	1.01	1.63	2.25	2.86	3.48	4.10	4.72	5.33	5.95	
	0.76	0.09	0.15	0.21	0.27	0.32	0.38	0.44	0.50	0.55	
	36	1.34	2.16	2.98	3.80	4.62	5.43	6.25	7.07	7.89	
	0.36	0.12	0.20	0.28	0.35	0.43	0.50	0.58	0.66	0.73	
	42	1.59	2.56	3.53	4.50	5.47	6.44	7.41	8.38	9.35	
	1.07	0.15	0.24	0.33	0.42	0.51	0.60	0.69	0.78	0.87	
	48	1.75	2.82	3.88	4.95	6.02	7.08	8.15	9.22	10.29	
	1.22	0.16	0.26	0.36	0.46	0.56	0.66	0.76	0.86	0.96	
	54	2.09	3.36	4.63	5.90	7.17	8.44	9.72	10.99	12.26	
	1.37	0.19	0.31	0.43	0.55	0.67	0.78	0.90	1.02	1.14	
60	2.33	3.75	5.17	6.59	8.02	9.44	10.86	12.28	13.70		
1.52	0.22	0.35	0.48	0.61	0.74	0.88	1.01	1.14	1.27		
66	2.56	4.12	5.68	7.24	8.80	10.36	11.92	13.48	15.04		
1.68	0.24	0.38	0.53	0.67	0.82	0.96	1.11	1.25	1.40		
72	2.83	4.55	6.28	8.00	9.72	11.45	13.17	14.90	16.62		
1.83	0.26	0.42	0.58	0.74	0.90	1.06	1.22	1.38	1.54		
78	3.10	4.98	6.87	8.76	10.65	12.54	14.42	16.31	18.20		
1.98	0.29	0.46	0.64	0.81	0.99	1.16	1.34	1.52	1.69		
84	3.36	5.41	7.46	9.50	11.55	13.60	15.65	17.70	19.75		
2.13	0.31	0.50	0.69	0.88	1.07	1.26	1.45	1.64	1.83		
90	3.59	5.79	7.98	10.17	12.36	14.55	16.74	18.94	21.13		
2.29	0.33	0.54	0.74	0.94	1.15	1.35	1.56	1.76	1.96		
96	3.83	6.16	8.50	10.83	13.17	15.50	17.84	20.17	22.51		
2.44	0.36	0.57	0.79	1.01	1.22	1.44	1.66	1.87	2.09		
102	4.16	6.69	9.23	11.77	14.30	16.84	19.37	21.91	24.44		
2.59	0.39	0.62	0.86	1.09	1.33	1.56	1.80	2.04	2.27		
108	4.41	7.09	9.78	12.47	15.15	17.84	20.53	23.21	25.90		
2.74	0.41	0.66	0.91	1.16	1.41	1.66	1.91	2.16	2.41		
114	4.65	7.49	10.33	13.17	16.01	18.84	21.68	24.52	27.36		
2.9	0.43	0.70	0.96	1.22	1.49	1.75	2.01	2.28	2.54		
120	4.90	7.89	10.88	13.87	16.86	19.85	22.84	25.83	28.82		
3.05	0.46	0.73	1.01	1.29	1.57	1.84	2.12	2.40	2.68		

AIR LEAKAGE (Damper fully closed)

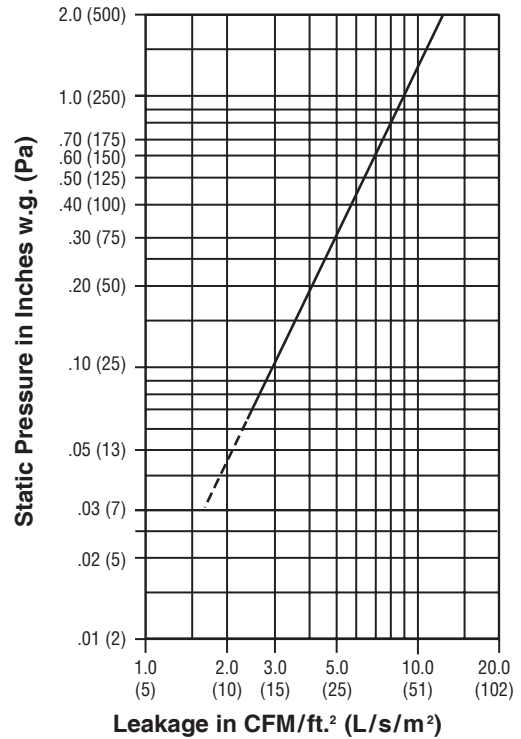

Louver test size: 48" x 48" (1219 x 1219 mm) with blade and jamb seals.

**AIRFLOW/ WATER PENETRATION DATA
for 48" x 48" (1219 x 1219) Louver Size**

Free Area %	51%	
Free Area sq. ft. (sq. m.)	8.15 (0.76)	
I N T A K E	Free Area Velocity at Point of Beginning Water Penetration at .01 oz./sq. ft. (3 ml/sq. m) (15 min. test duration)	970 fpm (296 m/min.)
	Air Volume at 970 fpm	7906 cfm (3731 l/s)
	Free Area Velocity	
	Pressure Drop @ 970 fpm	.17 in. w.g. (42 Pa)

NOTE: To minimize water penetration when sizing intake louvers, select a Free Area Velocity that is **below** the point of beginning water penetration.



Nailor Industries Inc. certifies the Model 1606AD shown herein is licensed to bear the AMCA Seal. The ratings shown are based on tests and procedures performed in accordance with AMCA Publication 511 and comply with the requirements of the AMCA Certified Ratings Program. Seal applies to air performance ratings and water penetration ratings.

PRESSURE DROP

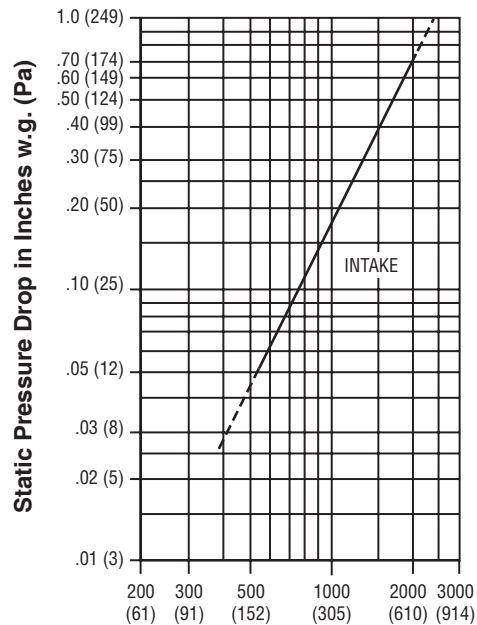

Louver test size: 48" x 48" (1219 x 1219 mm).

Standard air density @ 0.075 lbs/ft³. Tested to AMCA Fig. 5.5 - 6.5.

SCHEDULE TYPE:				
PROJECT:				
ENGINEER:	DATE	B SERIES	SUPERSEDES	DRAWING NO.
CONTRACTOR:	5 - 10 - 22	1600	5 - 30 - 19	1606AD