



# MANUAL BALANCING DAMPER MODEL: 1870 SINGLE BLADE

The Model 1870 Manual Balancing Damper is an economical branch duct balancing damper designed for use in most metal and fibre ductboard HVAC systems. The low profile frame and sills allow maximum free area. The ribbed forms in the blade and frame are for extra strength.

### STANDARD CONSTRUCTION:

- Frame:** 3" wide x 18 ga. (102 x 1.3) galvanized steel.
- Blade:** 20 ga. (1.0) galvanized steel up to 24" x 12" (610 x 305).  
18 ga. (1.3) galvanized steel above 24" x 12" (610 x 305).
- Shaft:** 1/4" (6) square plated steel.
- Quadrant:** Plated steel with locking operator (shipped loose).
- Minimum Size:** 4" x 4" (102 x 102).  
All units are manufactured 1/4" (6) under nominal size.
- Maximum Size:** 36" x 12" (914 x 305).  
All units are manufactured 1/4" (6) under nominal size.

**Temperature Range:** -50°F to approximately 180°F (-45°C to 82°C).

For larger units; refer to Models 1810 and 1820.

### ACCESSORIES:

- 2" (51) stand-off bracket for hand quadrant (for externally insulated duct).

### PERFORMANCE:

- Maximum System Pressure:** 2" w.g. (0.49 Kpa).
- Maximum Face Velocity:** 1500 fpm (7.6 m/s).

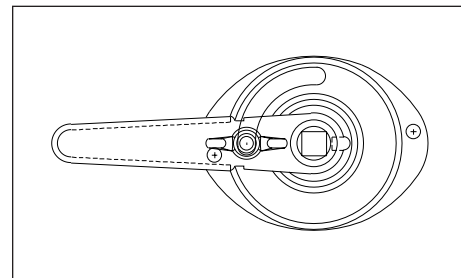
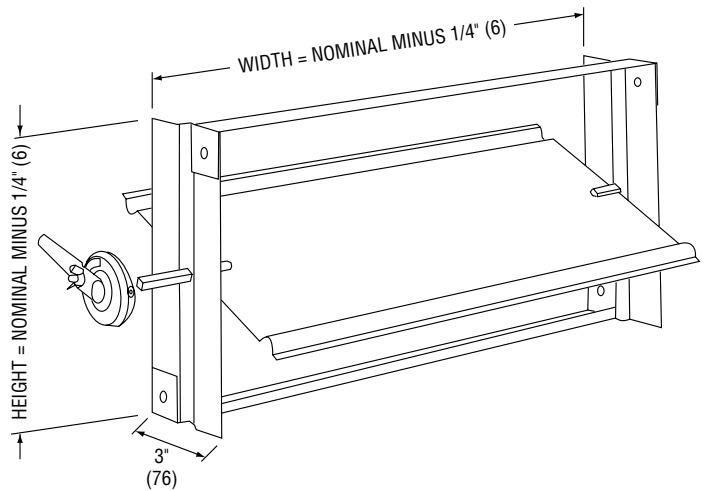

**LOCKING QUADRANT**

<b>SCHEDULE TYPE:</b>		Dimensions are in inches (mm).			
<b>PROJECT:</b>					
<b>ENGINEER:</b>	<b>DATE</b>	<b>B SERIES</b>	<b>SUPERSEDES</b>	<b>DRAWING NO.</b>	
<b>CONTRACTOR:</b>	10 - 5 - 99RR	1800	6 - 97	1800-2	