

The Nailor Model Series 1910/1920 is a heavy duty industrial control damper designed for use in medium to high pressure industrial HVAC or process air systems. Features include a vee blade design that offers precise airflow control or shut-off in applications involving pressure differentials of up to 8.5" w.g. (2.1 kPa) depending on width, and velocities up to 3000 fpm (15 m/s).

Models 1917/1927 feature 3/4" (19) dia. axles and are suitable for applications of up to 20" w.g. (5 kPa) pressure differential depending on damper width, and velocities up to 3500 fpm (18 m/s). The heavy duty flanged frame, with optional bolt holes, connects easily to flanged duct for fast, secure installation. Model Series 1910/1920 may be used for two-position or modulating control utilizing a selection of electric or pneumatic actuators, or can be operated manually with the optional locking hand quadrant.

STANDARD CONSTRUCTION:

- Frame:** 8" x 2" x 14 ga. (203 x 51 x 2) coated steel channel.
- Blades:** Approx. 6" (152) wide on 5 1/2" (140) centers, up to 8 5/8" (219) wide maximum depending on size. 16 ga. (1.6) galv. steel vee blade design. Parallel or opposed action.
- Linkage:** Heavy duty side linkage, concealed out of the airstream.
- Axles:** Models 1910/1920: 1/2" (13) dia. plated steel.
Models 1917/1927: 3/4" (19) dia. plated steel.
- Bearings:** Stainless Steel sleeve type.
- Drive Shaft:** 1/2" (13) or 3/4" (19) dia. (see Axles above) plated steel.
Extends 6" (152) beyond frame.
- Finish:** Mill galvanized.

Sizes (Duct W x H):

Minimum	Maximum
Single Section	Single Section
Single blade: 6" x 6" (152 x 152).	
Two blades (parallel or opposed): 6" x 10" (152 x 254).	48" x 96" (1219 x 2438)

Note: For larger sizes, contact factory.

Max. Performance Ratings	Models 1910/1920	Models 1917/1927
Maximum Velocity	3000 fpm (15 m/s)	3500 fpm (18 m/s)
Maximum Pressure	8.5 in. w.g. (2.1 kPa)	20 in. w.g. (5 kPa)
Maximum Temperature	250°F (121°C)	250°F (121°C)

Note: For higher operating temperatures, contact factory.

OPTIONS:

- 304 Type 304 Stainless Steel construction
- 316 Type 316 Stainless Steel construction
- 12GF 12 ga. (2.8) Frame
- 14GF 14 ga. (2.0) Blades
- AS50/75 Type 304 Stainless Steel axles only
- BEB External bolt-on ball bearings
- BEBS External bolt-on ball bearings with seal
- BOS Outboard bearings with seal
- BSE EPDM blade seals (up to 250°F [121°C])
- BSS Silicone blade seals (up to 400°F [204°C])
- JSS Stainless steel jamb seals

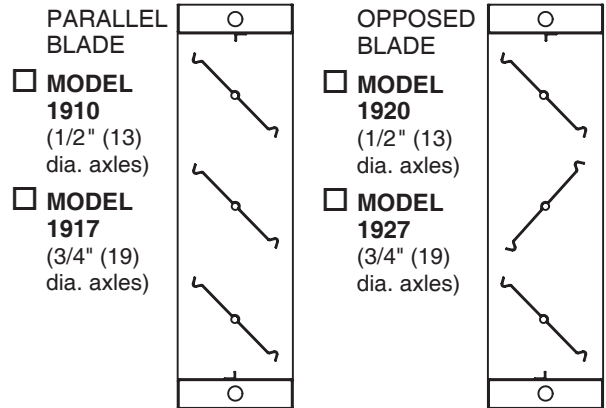
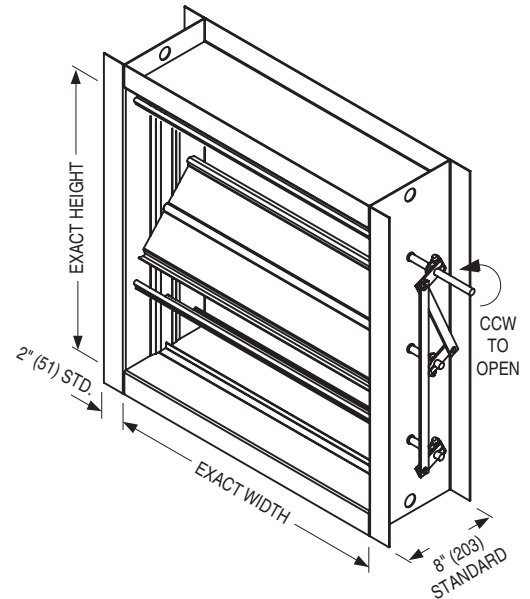

OPTIONS (continued):

- F15-F40 Non-standard flange width (1 1/2" [38] to 4" [102]). Specify _____.
- BH1 Bolt holes in one flange
- BH2 Bolt holes in both flanges
- HDLQ Heavy duty hand locking quadrant
- FMXX Factory mounted actuator.
Specify _____.
- Special Features _____.

Note: For variations not shown, contact factory.

SCHEDULE TYPE:	Page 1 of 2			
PROJECT:	Dimensions are in inches (mm).			
ENGINEER:	DATE	B SERIES	SUPERSEDES	DRAWING NO.
CONTRACTOR:	8 - 18 - 20	1900	6 - 30 - 14	1910



HEAVY DUTY INDUSTRIAL CONTROL DAMPERS
STEEL • VEE BLADE
PERFORMANCE DATA
MODELS: 1910/1920 & 1917/1927

PERFORMANCE LIMITATIONS:

Damper Width	Model 1910/1920		Model 1917/1927	
	Max. System Pressure	Max. System Velocity	Max. System Pressure	Max. System Velocity
48" (1219)	2.5 in. w.g.	3000 fpm	6.5 in. w.g.	3500 fpm
36" (914)	4.0 in. w.g.	3000 fpm	9.0 in. w.g.	3500 fpm
24" (610)	6.0 in. w.g.	3000 fpm	15.0 in. w.g.	3500 fpm
12" (305)	8.5 in. w.g.	3000 fpm	20.0 in. w.g.	3500 fpm

Pressure and velocity limitations shown are guidelines for design purposes. Although ratings are on the conservative side, contact Nailor for requirements beyond limitations shown.

LEAKAGE:

Damper Width	Model 1910/1920				Model 1917/1927			
	Leakage w/o Seals		Leakage with Seals		Leakage w/o Seals		Leakage with Seals	
	CFM per Sq. Ft.	% of Max. Flow	CFM per Sq. Ft.	% of Max. Flow	CFM per Sq. Ft.	% of Max. Flow	CFM per Sq. Ft.	% of Max. Flow
48" (1219)	31.5	1.05	4.2	0.14	31.5	0.90	4.2	0.12
36" (914)	31.5	1.05	4.2	0.14	31.5	0.90	4.2	0.12
24" (610)	39.0	1.30	8.5	0.28	39.0	1.12	8.5	0.24
12" (305)	59.0	1.97	13.0	0.43	59.0	1.69	13.0	0.37

Leakage data is based upon a pressure differential of 1 in. w.g., tested in accordance with AMCA Standard 500-D, Figure 5.5. For pressure differentials greater than 1 in. w.g. apply the appropriate leakage correction factor from the following chart:

Static Pressure (in. w.g.)	2	3	4	5	6	7	8	9	10	12	14	16	18	20
Correction Factor	x 1.4	x 1.7	x 2.0	x 2.2	x 2.4	x 2.6	x 2.8	x 3.0	x 3.2	x 3.5	x 3.7	x 4.0	x 4.2	x 4.5

PRESSURE DROP: SIZE: 36" x 36" (914 x 914)

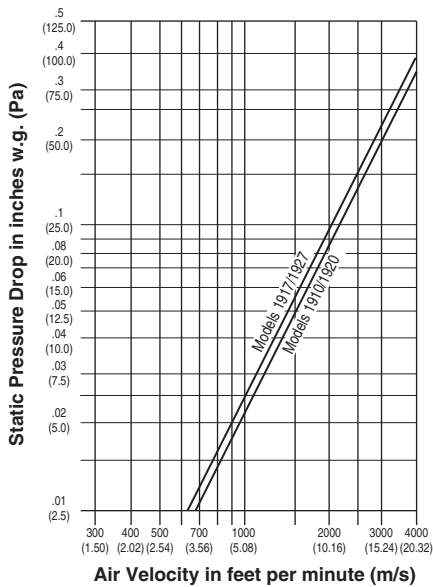

Tested per AMCA Standard 500-D using test set-up Figure 5.3, ductwork upstream and downstream.

SCHEDULE TYPE:	Page 2 of 2			
PROJECT:	Dimensions are in inches (mm).			
ENGINEER:	DATE	B SERIES	SUPERSEDES	DRAWING NO.
CONTRACTOR:	8 - 18 - 20	1900	6 - 30 - 14	1910