

Dimensional Data

Unit Size	Nominal CFM (l/s)	A	B	C	D	Filter Size
3	300 (142)	20 (508)	26 1/2 (673)	20 3/8 (518)	22 5/8 (575)	10 x 20 (254 x 508)
4	400 (189)	25 (636)	31 1/2 (800)	25 3/8 (645)	27 5/8 (702)	10 x 25 (254 x 635)
6	600 (283)	30 (762)	36 1/2 (927)	30 3/8 (772)	32 5/8 (829)	10 x 30 (254 x 762)
8	800 (378)	40 (1016)	46 1/2 (1181)	40 3/8 (1026)	42 5/8 (1083)	2@ 10 x 20 (254 x 508)
12	1200 (566)	50 (1270)	56 1/2 (1435)	50 3/8 (1286)	52 5/8 (1337)	2@ 10 x 25 (254 x 635)
15	1500 (708)	60 (1524)	66 1/2 (1689)	60 3/8 (1534)	62 5/8 (1591)	2@ 10 x 30 (254 x 762)

Electrical Data

Unit Size	Fan Qty.	Proportional ECM Motor FLA					3-Speed ECM Motor FLA					3-Speed PSC Motor FLA				
		Motor HP	120V	208V	240V	277V	Motor HP	120V	208V	240V	277V	Motor HP	120V	208V	240V	277V
3	1	1/4	1.8	0.8	0.7	0.7	1/8	1.8	0.8	0.7	0.7	1/30	0.7	0.4	0.5	0.4
4	1	1/4	2.3	1.4	1.4	1.2	1/8	2.3	1.4	1.4	1.2	1/15	1.3	0.8	0.8	0.8
6	2	1/4	2.1	1.5	1.3	1.2	1/8	2.1	1.5	1.3	1.2	1/10	1.7	0.9	0.9	0.9
8	2	1/4	2.8	1.9	1.8	1.6	1/4	2.8	1.9	1.8	1.6	1/6	2.1	1.0	1.1	1.0
12	3	2 @ 1/4	3.9	2.5	2.6	2.5	2 - 1/8, 1/4	3.9	2.5	2.6	2.5	2 - 1/6, 1/15	3.4	1.6	1.7	1.6
15	4	2 @ 1/4	4.4	3.0	2.9	2.7	2 @ 1/4	4.4	3.0	2.9	2.7	2 @ 1/6	4.1	2.0	2.1	2.0

FLA = Full load amperage (High Fan Speed). All motors are single phase/60 Hz.

SCHEDULE TYPE:		Page 1 of 3. Dimensions are in inches (mm)			
PROJECT:					
ENGINEER:	DATE	B SERIES	SUPERSEDES	DRAWING NO.	
CONTRACTOR:	4 - 3 - 23	40	4 - 11 - 22	40HP-2	



**LOW PROFILE HORIZONTAL FAN COIL UNITS
WITH PLENUM • PROPORTIONAL ECM, 3-SPEED ECM
OR PSC MOTOR • 2 PIPE COOLING & ELECTRIC HEAT
MODEL: 40HP TYPE ZE**

TYPE ZE: Chilled/Hot Water and Electric Heat
(2-pipe system)

Coil Options:

- 3 Row C/HW
- 4 Row C/HW

STANDARD FEATURES:

- Galvanized steel casing.
- 1/2" (13) dual density insulation, exposed edges coated to prevent air erosion. Meets the requirements of NFPA 90A and UL 181.
- Single point electrical connection.
- Discharge collar for duct connection.
- Rear return (field changeable) with 1" (25) throwaway filter.
- Bottom mounted hinged door controls enclosure.

MOTOR OPTIONS:

- Ultra-energy efficient proportional ECM fan motor(s) with thermal overload protection.
- Energy efficient 3-Speed ECM fan motor(s) with thermal overload protection.
- 3-Speed PSC fan motor(s) with thermal overload protection.

WATER COIL SECTION:

- 1/2" (12.7) copper tubes with aluminum ripple fins.
- Cooling coils include a foam insulated, galvanized steel sloped drain pan with 7/8" (22.2) O.D. primary drain connection. Field reversible.
- Left hand unit/coil connection as shown (looking in direction of airflow) is standard. Right hand is opposite.
- Manual air vents.
- Sweat Connections:
All 5/8" (15.9) O.D. male solder except size 15: 7/8" (22.2) O.D. male solder.

ELECTRIC HEAT:

- High-grade resistance elements mounted directory in front of fan outlet(s).
- Automatic reset high limit cut-outs (one per element).
- Single point power connection Voltage (single phase, 60 Hz):
 - 120V 208V
 - 240V 277V

OPTIONS AND ACCESSORIES:

- Foil face fiberglass liner.
 - Closed cell foam liner.
 - 1" (25) filters
 - MERV 8 pleated.
 - MERV 8 pleated with spare.
 - Throwaway with spare.
 - Bottom return.
 - Right hand unit/coil connection.
 - Toggle disconnect switch.
 - Door interlocking disconnect switch.
 - Drain pan float switch.
 - Factory assembled valve piping package (ships loose).
 - 5/8" (15.9) O.D. secondary drain connection.
 - Stainless steel drain pan.
 - Auxiliary drip pan (ship loose).
 - Outside Air Inlet (6" Left/Right/Back/Top Side).
 - Coil auto air vent(s).
 - Stainless steel coil casing.
 - 51FB Hinged filter grille (not available with CARP option).
 - Quiet type contactors.
 - Dust tight enclosure.
 - Main unit fusing.
 - Condensate pump.
 - 120V 120/230V
 - Supply air, 51SV single deflection grille or 51DV double deflection grille.
- Seismic Certification:
- SSI (Standard)
 - OSHPD
 - Special Features: _____

SCHEDULE TYPE:		Page 2 of 3.			
PROJECT:		Dimensions are in inches (mm)			
ENGINEER:	DATE	B SERIES	SUPERSEDES	DRAWING NO.	
CONTRACTOR:	4 - 3 - 23	40	4 - 11 - 22	40HP-2	

OPTIONAL BOTTOM PANEL ASSEMBLIES

- CARP** Ceiling Access Return Air Panel (bottom return only)
- CASP** Ceiling Access Solid Panel (rear return only)

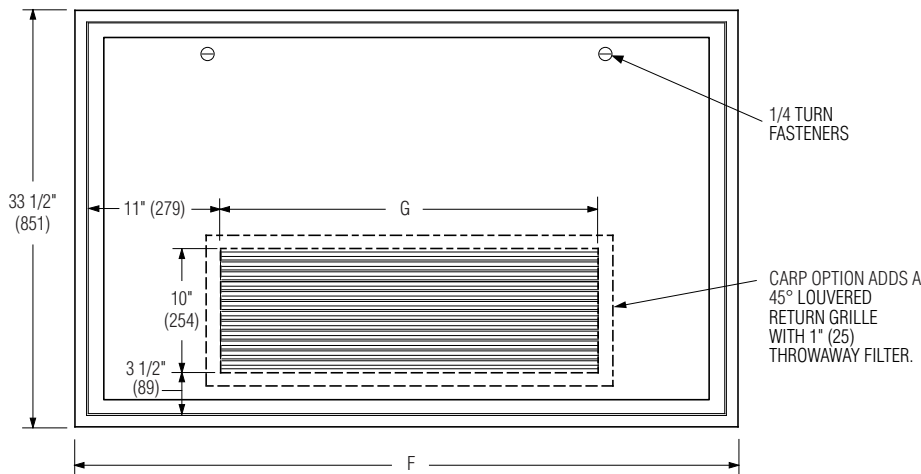
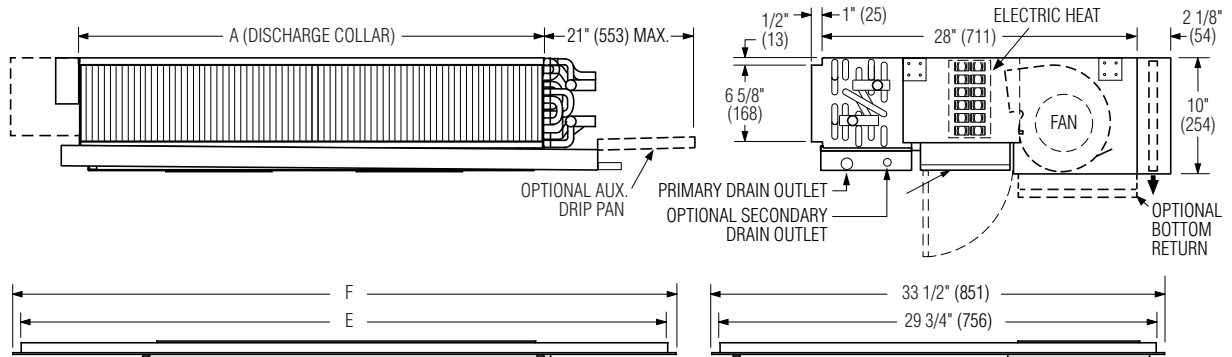

Dimensional Data

Unit Size	E	F	G	Filter Size
3	39 3/4 (1010)	43 1/2 (1105)	20 (508)	10 x 20 (254 x 508)
4	44 3/4 (1137)	48 1/2 (1232)	25 (635)	10 x 25 (254 x 635)
6	49 3/4 (1264)	53 1/2 (1359)	30 (762)	10 x 30 (254 x 762)
8	59 3/4 (1518)	63 1/2 (1613)	40 (1016)	2@ 10 x 20 (254 x 508)
12	69 3/4 (1772)	73 1/2 (1867)	50 (1270)	2@ 10 x 25 (254 x 635)
15	79 3/4 (2026)	83 1/2 (2121)	60 (1524)	2@ 10 x 30 (254 x 762)

NOTES:

- Left hand unit as shown, right hand unit is built as mirror image.
- 1/4-turn slotted fasteners. Qty. 2 for sizes 3 and 4, Qty. 3 for sizes 6 and 8, Qty. 4 for sizes 12 and 15.
- Minimum ceiling drywall opening should be cut as Panel Assembly neck dimension E x 29 3/4" (756) plus 1/4" (6).
- Standard finish is a durable baked enamel powder coat, AW appliance white powder finish. Custom colors are available.



SCHEDULE TYPE:				
PROJECT:				
ENGINEER:		DATE	B SERIES	SUPERSEDES
CONTRACTOR:		4 - 3 - 23	40	4 - 11 - 2
				DRAWING NO.
				40HP-2