

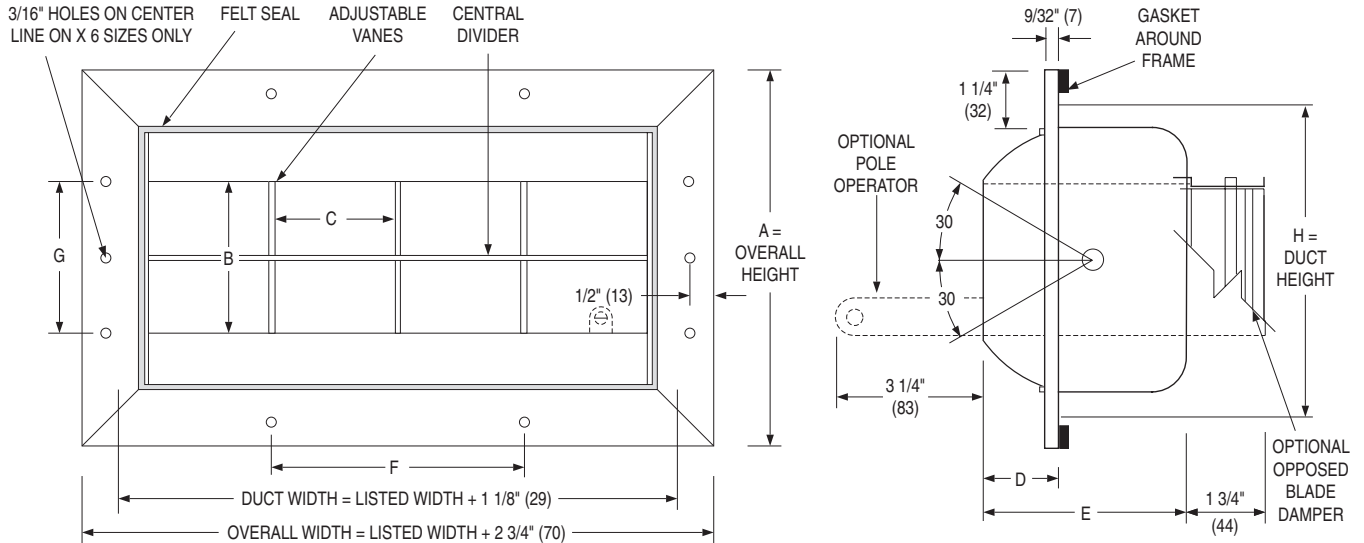

INDUSTRIAL SUPPLY GRILLES
DRUM LOUVER • ALUMINUM • HIGH CAPACITY
MODEL: 45DL2
(ADD -0 FOR OPTIONAL OBD)



AVAILABLE SIZES AND DIMENSIONAL DATA

Height	6		10		12		15	
	W x H	No. of Vanes	W x H	No. of Vanes	W x H	No. of Vanes	W x H	No. of Vanes
Listed Sizes Nominal Width x Height in Inches	9 x 6	2	18 x 10	2	18 x 12	2	18 x 15	2
	12 x 6	3	24 x 10	3	24 x 12	3	24 x 15	3
	15 x 6	4	30 x 10	4	30 x 12	4	30 x 15	4
	18 x 6	5	36 x 10	5	36 x 12	5	36 x 15	5
	24 x 6	7	42 x 10	6	42 x 12	6	42 x 15	6
	30 x 6	9	48 x 10	7	48 x 12	7	48 x 15	7
	36 x 6	11	54 x 10	8	54 x 12	8	54 x 15	8
	48 x 6	15	60 x 10	9	60 x 12	9	60 x 15	9
	54 x 6	17	66 x 10	10	66 x 12	10	66 x 15	10
	60 x 6	19	72 x 10	11	72 x 12	11	72 x 15	11

Dimensions in Inches (mm)	H	6 7/8 (175)	10 1/2 (267)	12 1/2 (318)	15 1/2 (384)
	A	8 1/2 (216)	12 1/8 (308)	14 1/8 (359)	17 1/8 (435)
	B	3 3/8 (86)	5 3/8 (137)	6 3/8 (162)	9 3/8 (238)
	C	3 (76)	6 (152)	6 (152)	6 (152)
	D	1 11/16 (43)	2 21/32 (67)	3 9/32 (83)	3 3/4 (95)
	E	4 1/2 (114)	6 1/4 (159)	7 1/8 (181)	8 3/4 (222)
	F	6 (152)	6 (152)	6 (152)	6 (152)
	G	-	6 (152)	6 (152)	9 (229)

DESCRIPTION:

1. Material: Extruded Aluminum.
2. Model 45DL2 is designed to handle large air capacities and provide long throws. It is ideally suited to applications where ductwork cannot be brought close to the occupants such as; shopping malls, industrial plants and stadiums.
3. Model 45DL2 incorporates two sets of pivoted adjustable deflecting vanes separated by a central divider, When the top and bottom set of vanes are set in opposite directions, the resulting turbulent counter-flow increases induction for more rapid mixing and shortens the throw.
4. Felt seal around drum minimizes air leakage.
5. Standard finish is AW Appliance white.

OPTIONS:

- Opposed blade damper. Model 45DL2-0
(Note: Not recommended where static pressure drop across drum louver exceeds 0.25" w.g.).
 - PB Pole Operator
- Finish:
- AL Aluminum
 - MI Mill
 - SP Special _____ .

SCHEDULE TYPE:	Dimensions are in inches (mm).			
PROJECT:				
ENGINEER:	DATE	B SERIES	SUPERSEDES	DRAWING NO.
CONTRACTOR:	11 - 5 - 18	4500	5 - 21 - 10	45DL2