

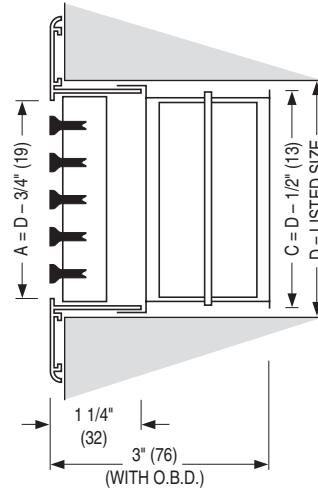

LINEAR BAR GRILLES AND REGISTERS

ALUMINUM • FIXED CORE

MODEL SERIES: 4900

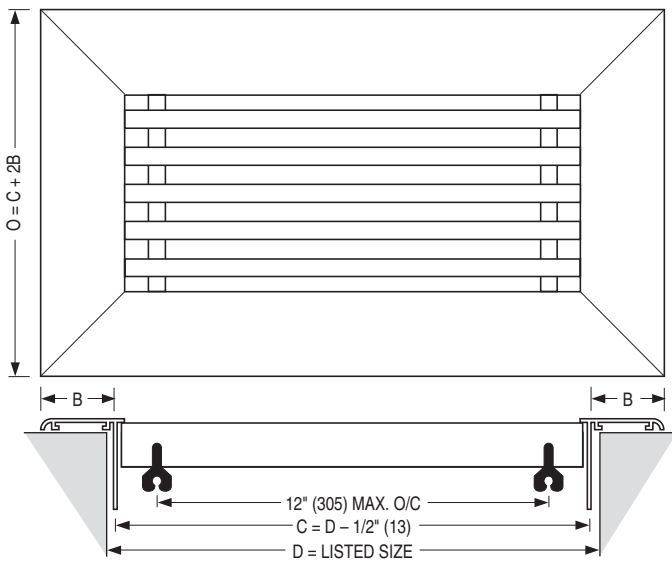

Series 4900 Extruded Aluminum Linear Bar Grilles and Registers are suitable for ceiling, sidewall or sill installation. End caps are staked and mitered. Min. nominal width = 1 1/2" (38). Max. nominal width = 24" (610). Available in 1/2" (13) nominal increments in width and 1" (25) in length. Maximum single section length = 72" (1829). Multiple-section assemblies are provided with alignment strips.

Dimensions are in inches (mm).

DAMPER SELECTION

(Optional)
 OPPOSED BLADE
 Corrosion-resistant steel.
 Minimum width = 2 1/2" (63).
 (Single blade with friction hinge on 1 1/2" [38] and 2" [51] widths.)

CORE SELECTION

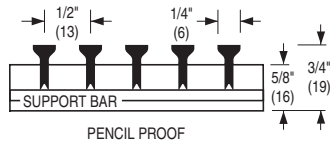

49-240 0° Deflection

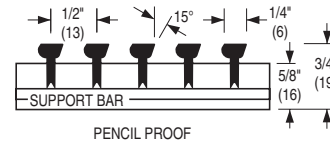

49-241 15° Deflection

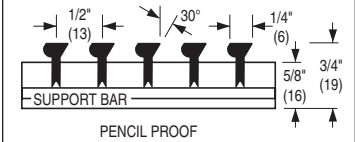

49-243 30° Deflection

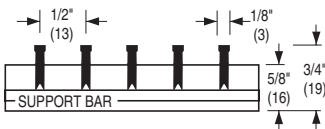

49-280 0° Deflection

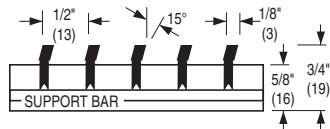

49-281 15° Deflection

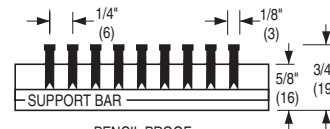

49-480 0° Deflection

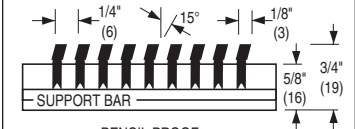

49-481 15° Deflection

FRAME SELECTION

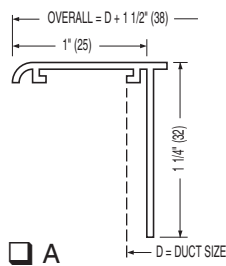

A

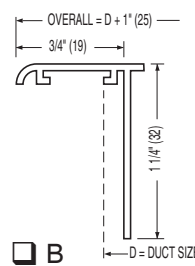

B

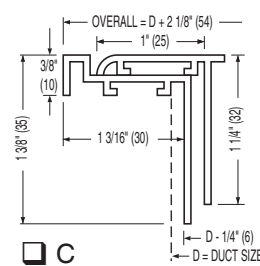

C

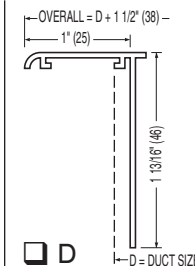

D

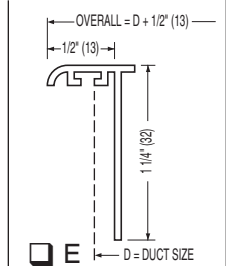

E

FASTENING SELECTION

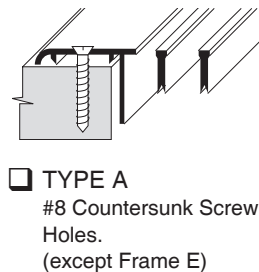

TYPE A
 #8 Countersunk Screw Holes.
 (except Frame E)

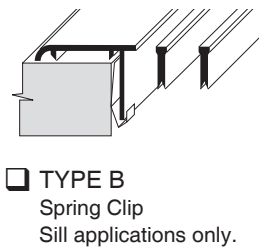

TYPE B
 Spring Clip
 Sill applications only.

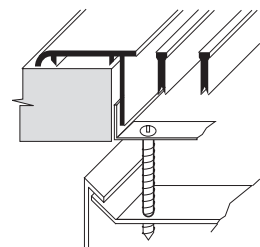

TYPE C Concealed Mounting Bracket - (not recommended for cores with 1/4" (6) spacing).

FINISH:

- AW Appliance White
- AL Aluminum
- SA Satin (clear) Anodized
- BC Brushed clear-coat lacquer
- MI Mill
- SP Special

SCHEDULE TYPE:

PROJECT:

ENGINEER:

CONTRACTOR:

DATE

B SERIES

SUPERSEDES

DRAWING NO.

4 - 28 - 23

4900

9 - 18 - 20

4900-1