

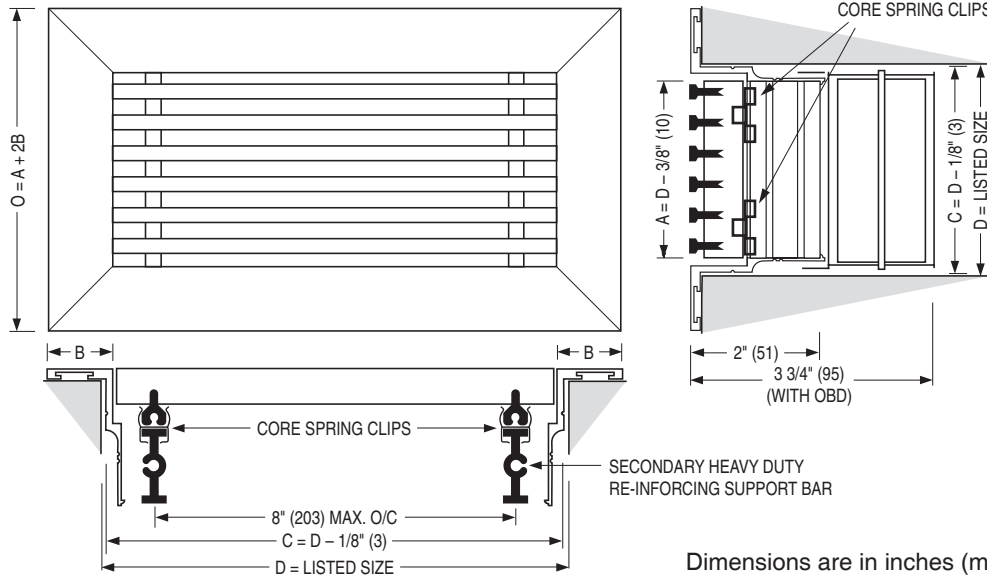

HEAVY DUTY LINEAR BAR GRILLES AND REGISTERS

ALUMINUM • REMOVABLE CORE

MODEL SERIES: 4900



Designed for floor or sill installations. End caps are staked, welded and mitered. Standard heavy duty reinforced core utilizes an additional cross-bar support. Spacing does not exceed 8" (203) on centers. Core are removable and supplied with core spring clips as standard. Structural support designed and installed by others. Available in 1/2" (13) nominal increments in width and 1" (25) in length.

DAMPER SELECTION

(Optional)
 OPPOSED BLADE
 Corrosion-resistant steel. Minimum width = 2 1/2" (63). (Single blade with friction hinge on 1 1/2" [38] and 2" [51] widths.)

Dimensions are in inches (mm).

CORE SELECTION

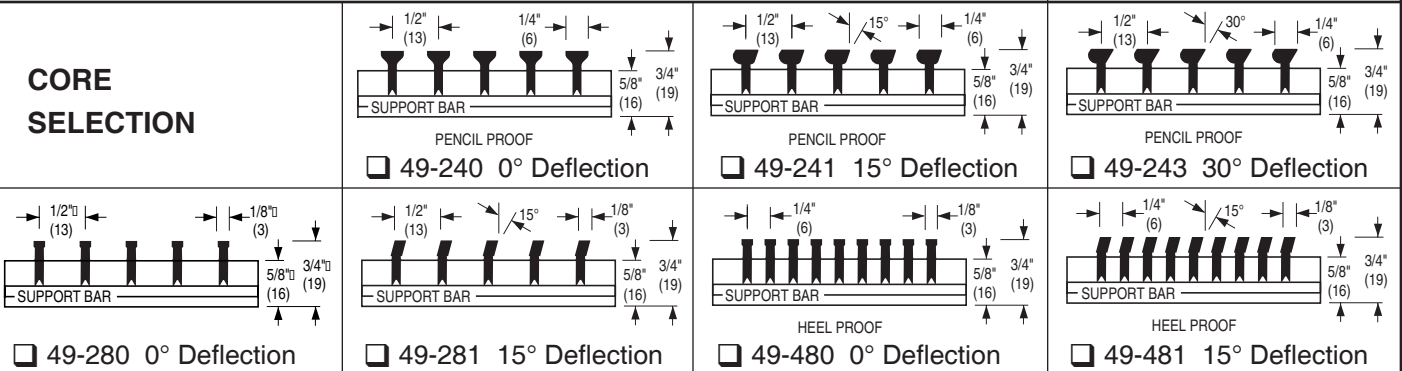

FRAME SELECTION

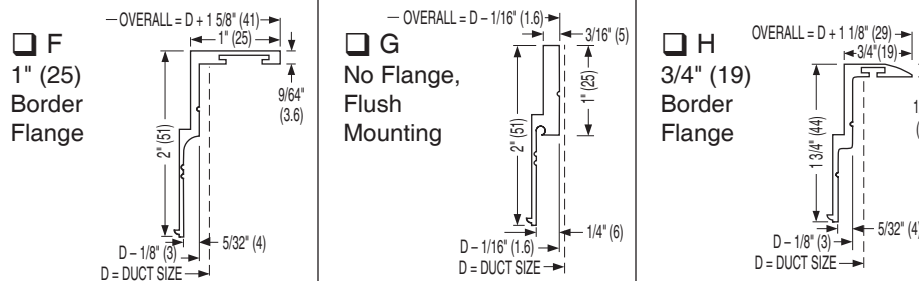

- FINISH:**
- AW Appliance White
 - AL Aluminum
 - SA Satin (clear) Anodized
 - BC Brushed clear-coat lacquer
 - MI Mill
 - SP Special

FASTENING SELECTION

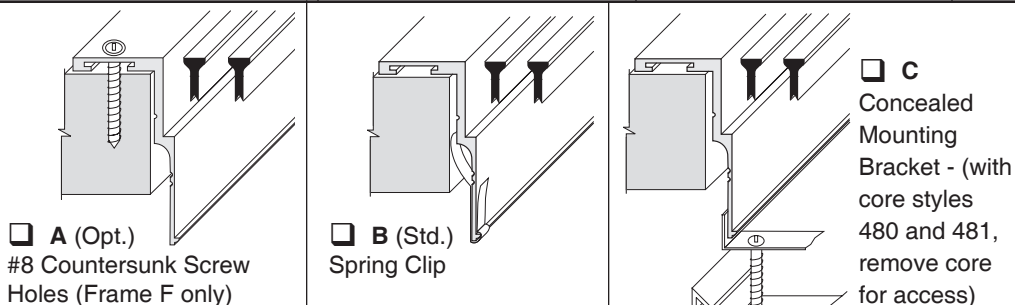

- N None (Lay-in)

SCHEDULE TYPE:

PROJECT:

ENGINEER:

CONTRACTOR:

DATE

B SERIES

SUPERSEDES

DRAWING NO.

4 - 28 - 23

4900

10 - 28 - 21

4900-2