

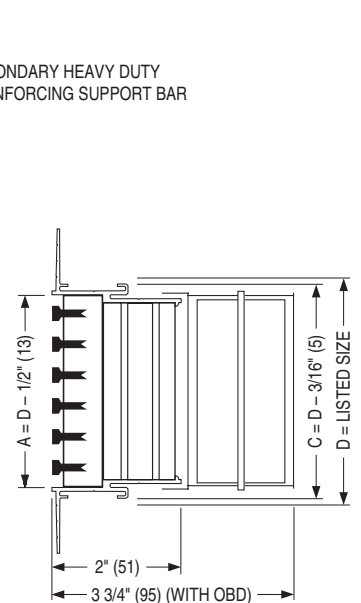

HEAVY DUTY LINEAR BAR GRILLES AND REGISTERS
ALUMINUM • TAPE AND SPACKLE FRAME
REMOVABLE CORE
MODEL SERIES: 4900

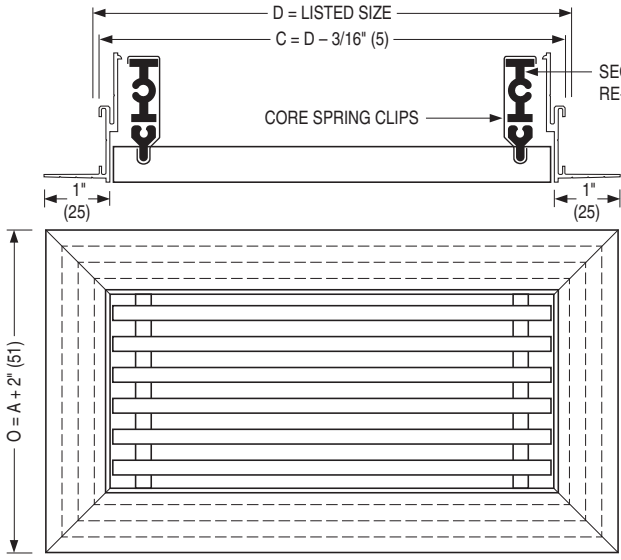

Designed for ceiling or sidewall installation.
 Mitered end caps.
 Standard heavy duty reinforced core utilizes an additional cross-bar support.
 Core is removable and supplied with core clips as standard.
 Min. nominal width = 1 1/2" (38).
 Max. nominal width = 24" (610).
 Available in 1/2" (13) nom. increments in width and 1" (25) in length.
 Max. single section length = 72" (1829).
 (Multiple-section assemblies are provided with alignment strips).

DAMPER SELECTION
 (Optional)
 OPPOSED BLADE
 Corrosion-resistant steel.
 Minimum width = 2 1/2" (63).
 (Single blade with friction hinge on 1 1/2" [38] and 2" [51] widths.)

CORE SELECTION

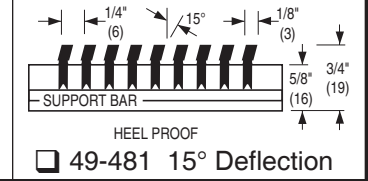
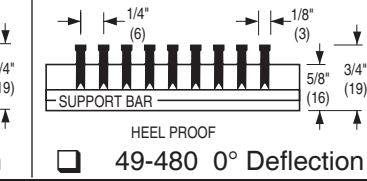
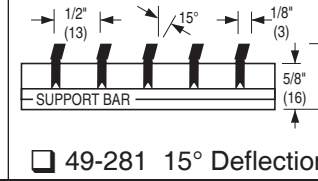
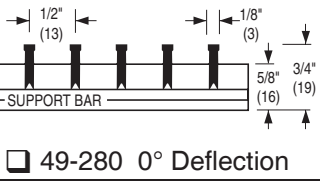
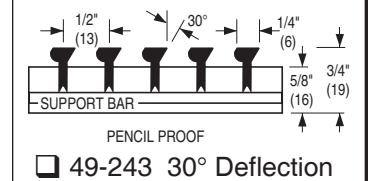
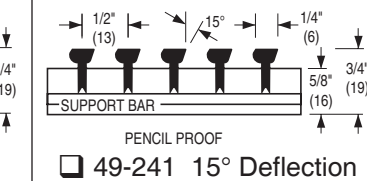
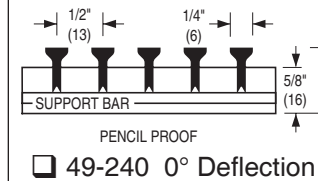

FRAME SELECTION

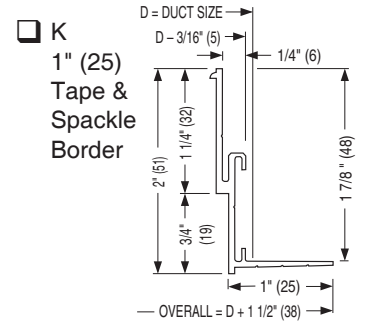

FASTENING SELECTION

- Type A
#8 Countersunk screw holes
- Type HC5
Hard Ceiling Clips for 1/2" (13) drywall
- Type HC1
Hard Ceiling Clips for 5/8" (16) drywall

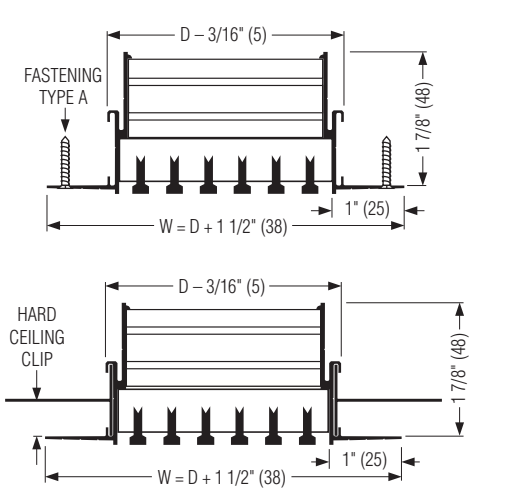

FINISH

- AW Appliance White
- AL Aluminum
- SA Satin (clear) Anodized
- BC Brushed clear-coat lacquer
- MI Mill
- SP Special

SCHEDULE TYPE:
PROJECT:
ENGINEER:
CONTRACTOR:

DATE	B SERIES	SUPERSEDES	DRAWING NO.
4 - 28 - 23	4900	10 - 25 - 22	4900-6

Dimensions are in inches (mm).