

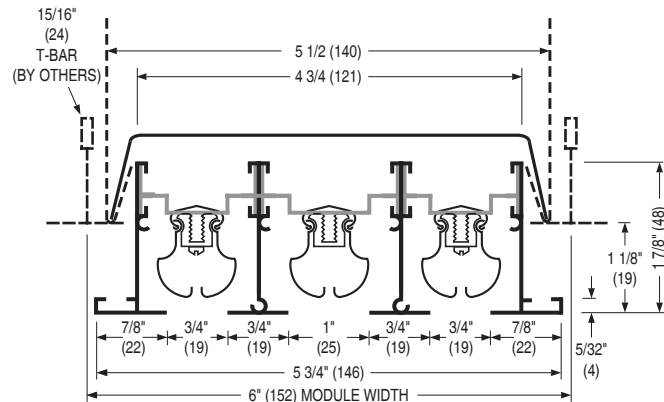

LINEAR SLOT DIFFUSERS
 EXTRUDED ALUMINUM • FOR CERTAINEED TECHSTYLE CEILING
 APPLICATIONS • 6" WIDE
MODELS: 5075TS SUPPLY AND 5075TSR RETURN
FRAME TYPE TSD - CONCEALED 15/16" (24) FLAT T-BAR

Supply Model

5075TS



Return Model

5075TSR

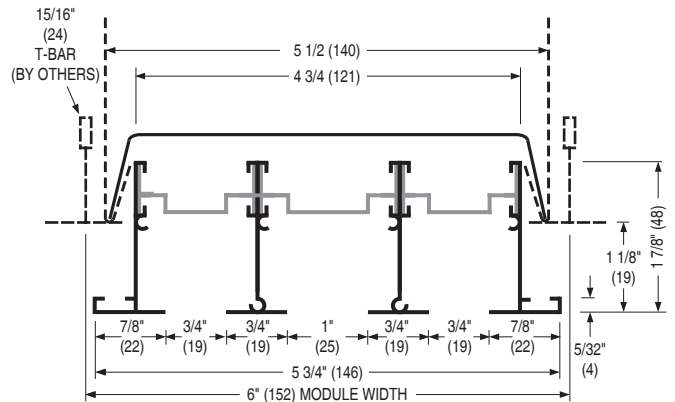

Mounting:

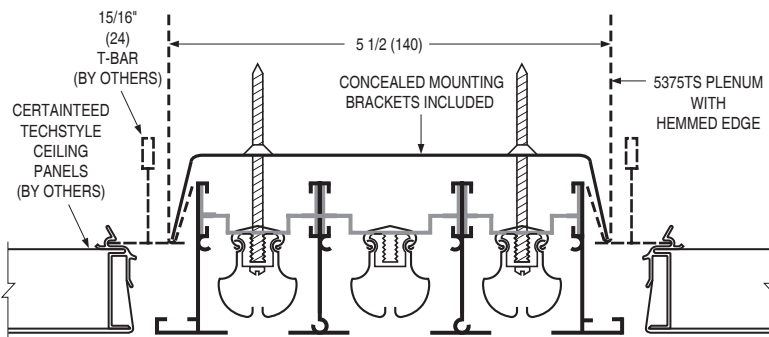

Module Width	No. of Slots
6" (152)	3

End Cap Configuration: Type F - Flanged End Cap

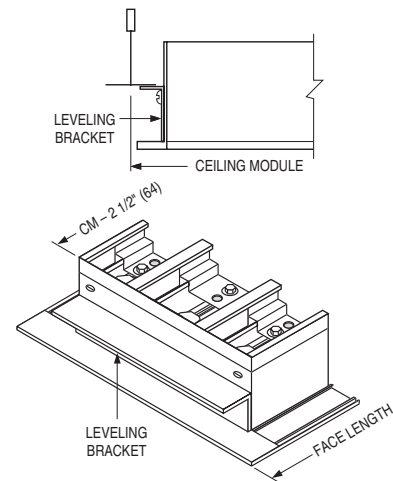

End Condition	Face Length
FF	Ceiling Module - 1/4" (6)

NOTES:

- Compatible with Certainteed Techstyle Ceiling Systems with 6" (152) module width and Swing Down 1 1/8" (29) drop panels for 15/16" (24) Flat T-Bar or Echelon grid mounting.
- Material: Extruded aluminum frame. Corrosion-resistant steel pattern controllers.
- 3/4" (19) and 1" (25) combination nominal slot widths with frame type TSD 7/8" (22) border
- Available in 24" (610), 30" (762), 48" (1219), 60" (1524) and 72" (1829) standard module lengths. Ends are finished with Type FF flanged end caps and leveling bracket.
- The volume and direction of the discharge air can be adjusted by moving the pattern controllers.
- 5075TSR is a matching return diffuser and supplied without pattern controllers.
- The maximum length of the pattern controller is 36" (914). Diffusers longer than 36" (914) are provided with multiple pattern controller sections.
- Standard finish is AW Appliance White. Black pattern controllers. Custom colors are available
- For performance data; see Nailor catalog Model 5075.

OPTIONS:
FACTORY SUPPLIED PLENUM

- 5375TS 5375TSI Insulated

See separate submittal for full specification and dimensional data.

SCHEDULE TYPE:

PROJECT:

ENGINEER:

CONTRACTOR:

Dimensions are in inches (mm).

DATE	B SERIES	SUPERSEDES	DRAWING NO.
8 - 7 - 23	5000	NEW	5075TS-1