

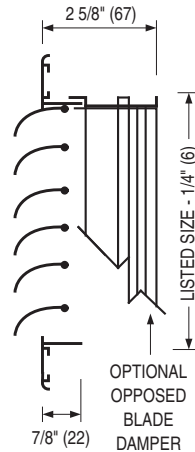

**ALUMINUM CURVED BLADE
GRILLES & REGISTERS
ONE-WAY DISCHARGE PATTERN
MODELS: 51C(-O) AND 51CD(-O) TYPE S**

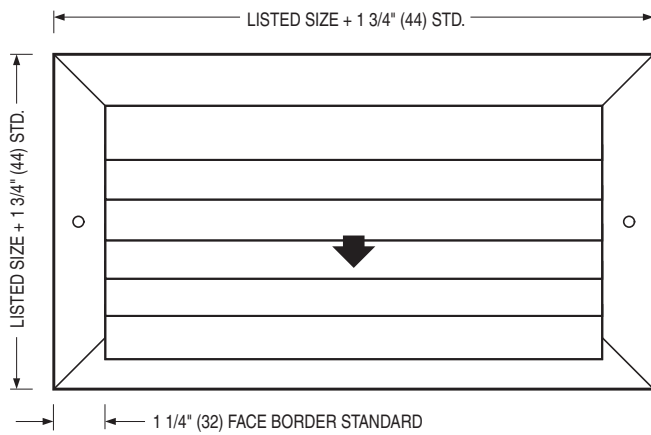

MODEL 51C
Curved Blade Grille
1-Way Discharge Pattern

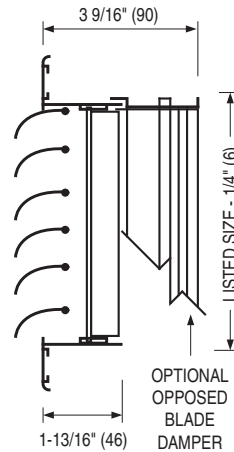
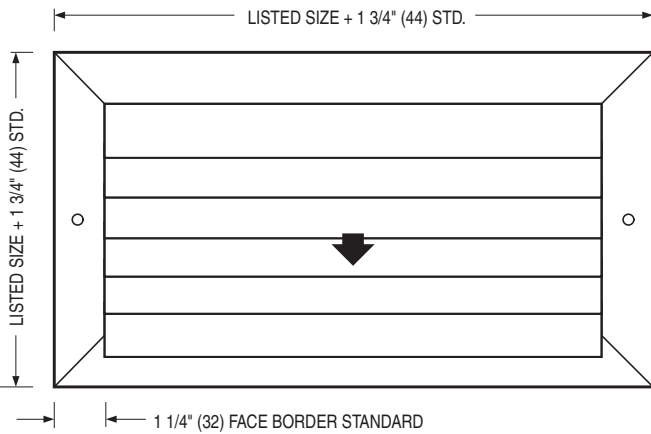

MODEL 51C-O
Curved Blade Register
1-Way Discharge Pattern
(Includes O. B. Damper)



MODEL 51CD
Curved Blade Grille with
rear directional vanes
1-Way Discharge Pattern

MODEL 51CD-O
Curved Blade Register with
rear directional vanes
1-Way Discharge Pattern
(Includes O. B. Damper)

DESCRIPTION:

- Construction: Extruded aluminum blades and frame. Curved vanes on 1" (25) centers. Frame is mechanically inter-locked for strength with hairline miters. Rear adjustable equalizing vanes on 51CD models are "teardrop" on 3/4" (19) centers. Roll-formed steel opposed blade damper on registers has screwdriver slot operator.
- The min. size is 6" x 4" (152 x 102). The maximum size is 36" x 36" (914 x 914).
- Discharge Pattern Selection:**
 1A 1B

- Type S Surface mount standard frame has a 1 1/4" (32) face border and a 1" (25) overlap margin.
- Curved blades are individually adjustable and regulate angle of discharge.
- Standard fastening is Type A countersunk screwholes.
- Standard finish is AW Appliance White.

OPTIONS:

- Finish:
 SP Special _____ .
- Fastening:
 Type C Concealed mounting straps
 Type D Concealed screwholes in neck
 Type N None
- Type FB Fixed Curved Blades
- OA Aluminum opposed blade damper (model suffix)
- Type NF Narrow frame with 1" (25) face border and a 3/4" (19) overlap margin. O.A. flange to flange dim. = listed size + 1 1/4" (32).
- PF Plaster sub-frame
- IS Insect screen
- Other _____ .

SCHEDULE TYPE:

PROJECT:

ENGINEER:

CONTRACTOR:

Dimensions are in inches (mm).

| DATE | B SERIES | SUPERSEDES | DRAWING NO. |
|------------|----------|-----------------|-------------|
| 2 - 1 - 11 | 5100 | 5100-6/15-3-00R | 51C-1 |