

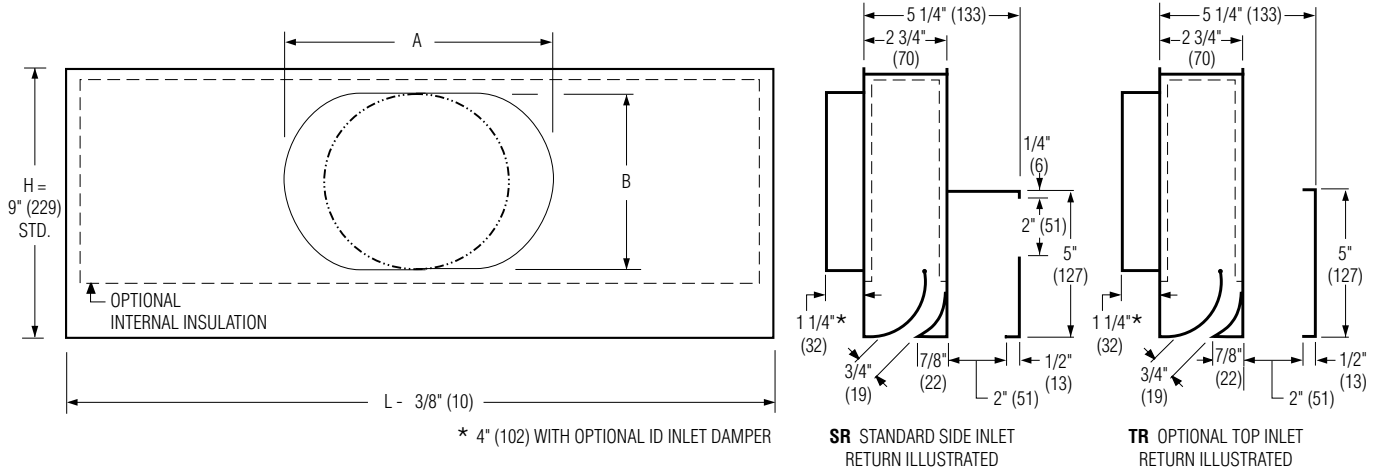

N SERIES PLENUM SLOT DIFFUSER
SUPPLY / RETURN • PREMIUM PERFORMANCE
HORIZONTAL DISCHARGE
MODEL: 59NR (I)



Nominal Length L		Available Inlet Sizes
Imperial Modules	Metric Modules	
24 (610)	600	6, 8, 10 (152, 203, 254)
36 (914)	900	
48 (1219)	1200	
60 (1524)	1500	

Nominal Inlet Size	Std. Dimension H = 9		Opt. Dimension H = 11		Opt. Dimension H = 7	
	A	B	A	B	A	B
6 (152)	—	5 7/8 (149)	—	5 7/8 (149)	7 (178)	4 (102)
8 (203)	9 (229)	5 7/8 (149)	—	7 7/8 (200)	10 1/8 (257)	4 (102)
10 (254)	12 1/8 (308)	5 7/8 (149)	11 (279)	7 7/8 (200)	13 1/4 (337)	4 (102)

Inlets are round or oval as dimensioned.

DESCRIPTION:

- The 59NR Supply/Return Plenum Slot Ceiling Diffusers have been designed for standard lay-in T-Bar application.
- The 59NR design provides premium performance. An aerodynamic extruded aluminum pattern controller provides a fixed horizontal discharge and produces a tight blanket of air into the room, maximizing coanda effect and induction of room air.
An integral return air section returns room air into the ceiling plenum, with minimal short-circuiting of supply air. Standard (SR) side inlet return section also acts as a light shield and prevents see through.
- The design is excellent for VAV, heating and cooling applications.
- Standard nominal lengths are 24", 36", 48" and 60" to suit imperial ceiling grids. Metric units are available. Standard H9 plenum height is 9" (229). Standard inlet sizes are 6" round, 8" and 10" flat oval.
- Plenum is corrosion resistant steel.
- Finish: BK Black pattern controllers and exposed edges.

OPTIONS (see submittal 59N_BS-ACC for details):

- EX External Foil Back Insulation
- Internal Insulation. Model 59NRI
 - FGI 1/4" (6) Coated Fiberglass (default)
 - FFI 3/8" (10) Fiber-Free Foam
- ID Inlet Damper

- PF Plaster Frame
- Supplementary T-Bars
 - T1 One (inlet side)
 - T0 One (opposite inlet side)
 - T2 Two (Both sides)
- Mounting Clips
 - M1 One side (2 opposite inlet side)
 - M2 Both sides (4)
- Fineline/Bolt-Slot T-Bar Ceiling Construction (24" [610] and 48" [1219] nominal length only)
Cross notch not available
T-Bar Height
 - FNLA 1 3/4" (44)
 - FNLC 1 5/8" (41)
 - FNLD 1 25/32" (45)
- EQT Earthquake Tabs
- EC 3" (76) Extended inlet collar w/bead
- TR Top inlet return section
- Non-standard Plenum Height
 - H7 7" (178) high
 - H11 11" (279) high
- FS Diamond Flow Sensor w/extended collar bead. Requires H11 option. 6" (152) and 8" (203) round inlet sizes only. (Not available on models with internal insulation).
- SP Special features _____.

SCHEDULE TYPE:

PROJECT:

ENGINEER:

CONTRACTOR:

Dimensions are in inches (mm).

DATE	B SERIES	SUPERSEDES	DRAWING NO.
4 - 28 - 14	5900	5 - 11 - 09	59NR