

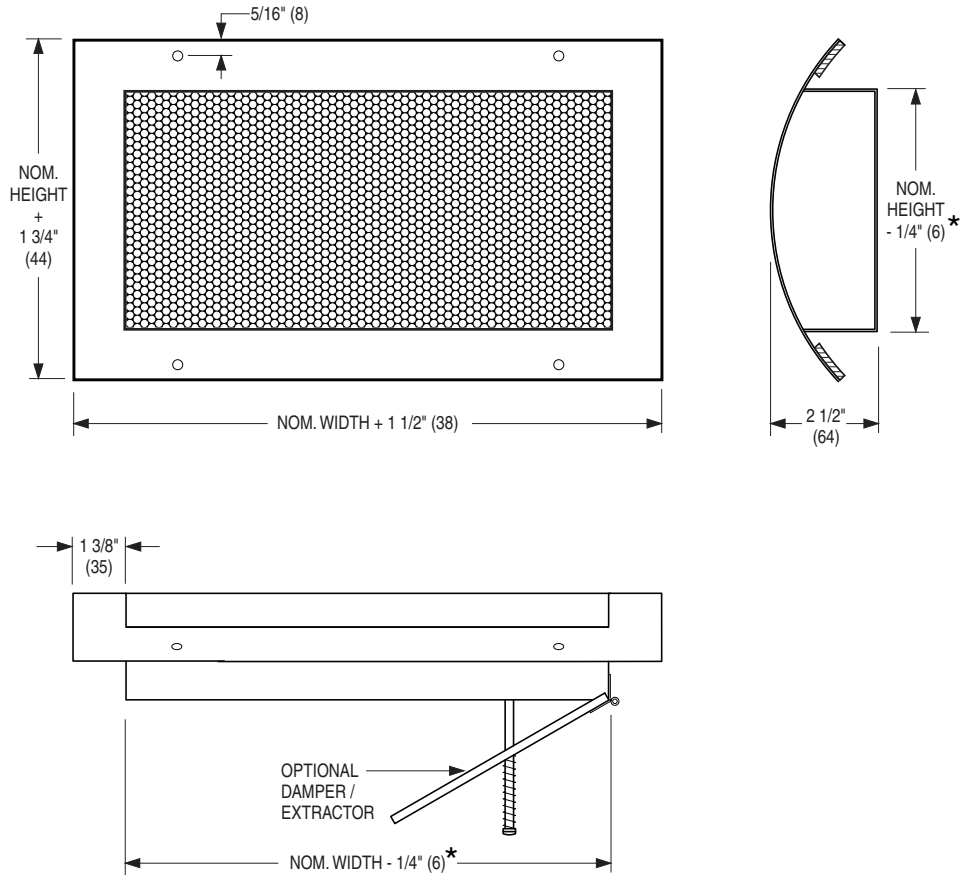

STEEL CURVED SPIRAL DUCT GRILLES
 TRUE FULL RADIUS DESIGN
 PERFORATED FACE • RETURN
MODELS: 61PRC

MODEL 61PRC
 Perforated Face



Available Sizes

Grille Width Min. - Max.	Grille Height	Duct Diameter Min. - Max.
10 - 48 (254 - 1219)	3 (76)	6 - 36 (152 - 914)
10 - 48 (254 - 1219)	4 (102)	6 - 36 (152 - 914)
10 - 48 (254 - 1219)	6 (152)	8 - 36 (203 - 914)
10 - 48 (254 - 1219)	8 (203)	10 - 36 (254 - 914)
10 - 48 (254 - 1219)	10 (254)	12 - 36 (305 - 914)
12 - 36 (305 - 914)	12 (305)	14 - 36 (356 - 914)

Duct diameters in even sizes only. Grilles available in nominal 1" (25) increments in width.

* Opening = Nominal + 1/4" (6) with DEX Damper/Extractor option.

Important:

Grilles are custom fabricated to fit only a single specified duct diameter.

DESCRIPTION:

- Nailor's unique curved spiral duct grille design offers an architecturally superior appearance and saves installation time and money by directly mounting to the duct and hence eliminating the need to fabricate stand-off saddles for standard grilles. The 61PRC may be used for supply and/or return air applications.
- Construction: Unique architectural single piece corrosion-resistant steel frame design is rolled to match required duct radius, eliminating unsightly non-aligned butted corners. Perforated face has 3/16" (5) dia. holes on staggered 1/4" (6) centers. 51% free area.
- A thick foam gasket is provided as standard to ensure a tight seal to duct.
- Standard fastening is Type A screw holes.
- Standard finish is AW Appliance White.

Options:

- DEX Damper/Extractor* (Air scoop) (For supply air applications).
- Finish:
 - AL Aluminum.
 - MI Mill.
 - SP Special. Specify _____.

SCHEDULE TYPE	Dimensions are in inches (mm).			
PROJECT				
ENGINEER	DATE	B SERIES	SUPERSEDES	DRAWING NO.
CONTRACTOR	9 - 22 - 11	6100C	4 - 12 - 11	6100C-3