

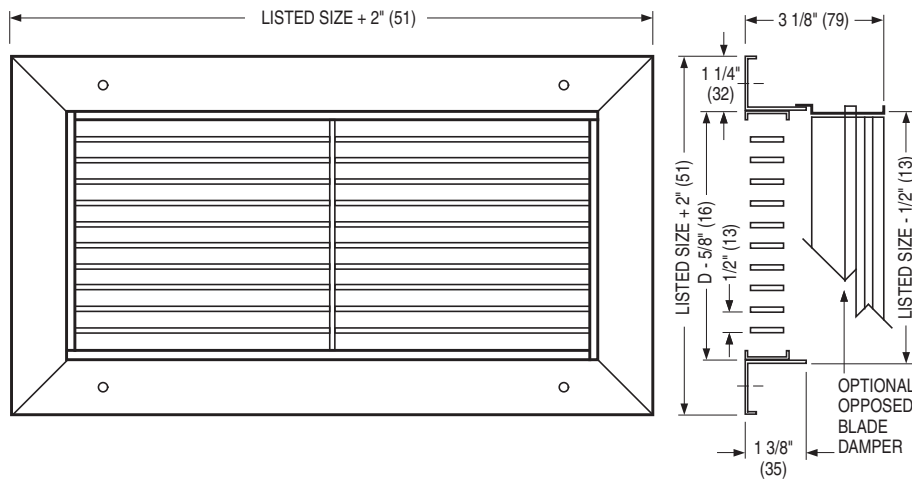

STEEL HEAVY DUTY SUPPLY GRILLES & REGISTERS • GYMNASIUM
SINGLE DEFLECTION • LOUVERED
MODELS: 61SH-HD(-O) AND 61SV-HD(-O)



MODEL 61SH-HD
 Single Deflection Grille
 Horizontal Blades

MODEL 61SH-HD-O
 Single Deflection Register
 Horizontal Blades
 (Includes O. B. Damper)

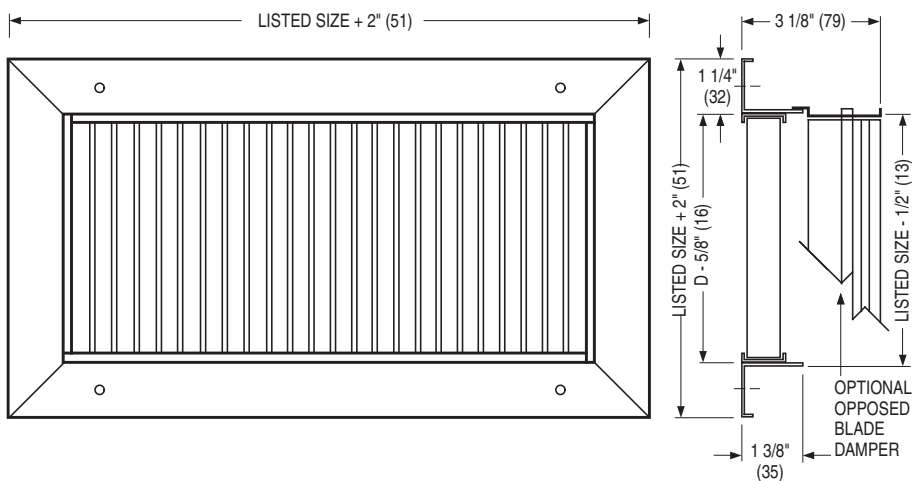

MODEL 61SV-HD
 Single Deflection Grille
 Vertical Blades

MODEL 61SV-HD-O
 Single Deflection Register
 Vertical Blades
 (Includes O. B. Damper)

DESCRIPTION:

1. Material: Heavy gauge steel.
2. Construction: A single set of 14 gauge blades on 1/2" (13) centers provide air control in a single plane. Blades are individually adjustable, 0 - 40° deflection. Frame is heavy duty 16 gauge material with welded and reinforced mitered corners.
3. The 6100-HD Series heavy duty grilles are constructed to offer the strength and rigidity required in order to withstand abuse in applications such as gymnasiums, schools, parking lots and other locations requiring strong impact resistance.
4. Optional opposed blade damper has a screwdriver slot operator accessible through the face of the register.
5. Available in duct sizes 6" x 4" (152 x 102) through 48" x 48" (1219 x 1219) maximum.

6. Fastening: Countersunk screwholes with oval head screws.
7. Standard Finish is AW Appliance White.

OPTIONS:

1. Finish:
 - SP Special _____ .
2. Other: _____ .

SCHEDULE TYPE:

PROJECT:

ENGINEER:

CONTRACTOR:

Dimensions are in inches (mm).

DATE	B SERIES	SUPERSEDES	DRAWING NO.
2 - 1 - 11	6100	1 - 30 - 04	6100HD-1