

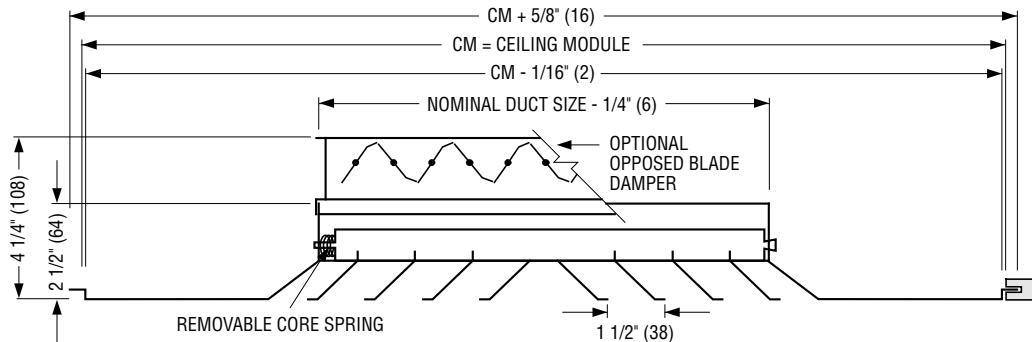

PATTERN CEILING DIFFUSERS
ALUMINUM • SQUARE, RECTANGULAR OR
ROUND NECK
MODELS: 6200 AND 6200-O TYPE SP

TYPE SP SPLINE



If the ceiling module is not 3" (76) larger than the neck size of the diffuser in both dimensions, a steel, module sized extended panel will be added.
 Minimum duct size: 6 x 6 (152 x 152).
 Maximum duct size: see table.
 Available in 3" (76) increments only.

IMPERIAL MODULES				METRIC MODULES	
Imperial Units (in.)	Metric Units (mm)	Imperial Units (in.)	Metric Units (mm)	Imperial Units (in.)	Metric Units (mm)
CM	Maximum Duct Size	CM	Maximum Duct Size	CM	Maximum Duct Size
12 x 12	9 x 9	305 x 305	229 x 229	300 x 300	152 x 152
24 x 12	21 x 9	610 x 305	533 x 229	600 x 300	457 x 152
24 x 24	21 x 21	610 x 610	533 x 533	600 x 600	457 x 457

CORE STYLE SELECTION

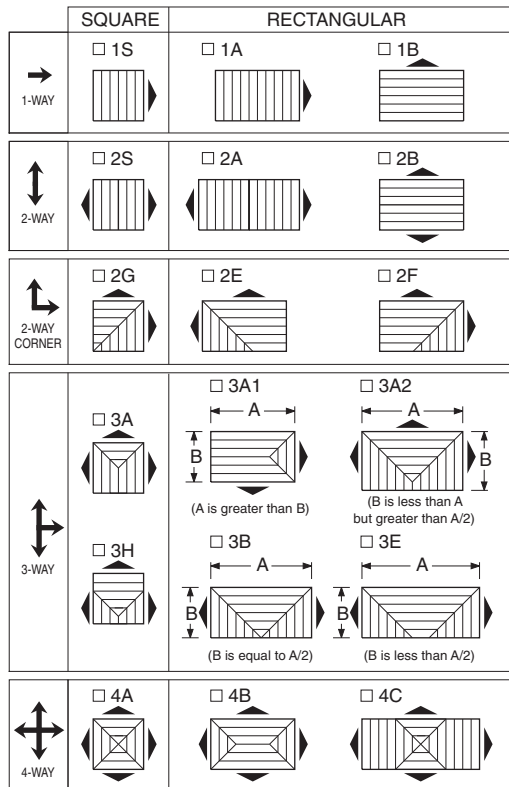

Patterns are shown in plan view (looking down into inlet).

Spline Type Diffuser for one-directional exposed T-bar lay-in grid or for concealed T-bar grid (splines on two opposite sides - steel lift brackets on other two sides).

DESCRIPTION:

1. Material: Aluminum. Extended panel where required is corrosion-resistant coated steel.
2. Model 6200 is a high capacity ceiling diffuser available in 1, 2, 3 or 4-way blow patterns to provide a tight horizontal airflow pattern from maximum to minimum airflow. Ideal for VAV applications.
3. Spring-loaded removable core.
4. Standard finish is AW Appliance White.

OPTIONS:

- PLA Aluminum Extended Panel.
- SQUARE AND RECTANGULAR NECK**
- Steel opposed blade damper. Model 6200-O.
- Aluminum opposed blade damper. Model 6200-OA.
- ROUND NECK**

- SR Square to round transition collar
- SR-O Square to round transition collar for use over O.B.D.
- 4275 Radial Opposed Blade Damper (round)
- 4250 Radial Sliding Blade Damper (round)
- 4675 Butterfly Damper (round)

EXTERNAL INSULATION

- EX External Foil-Back Insulation, installed -R-4.2.

OPTIONAL FINISH:

- SP Special. Specify _____ .

SCHEDULE TYPE:

PROJECT:

ENGINEER:

CONTRACTOR:

Dimensions are in inches (mm).

DATE

B SERIES

SUPERSEDES

DRAWING NO.

2 - 8 - 18

6200

11 - 24 - 16

6200-3