

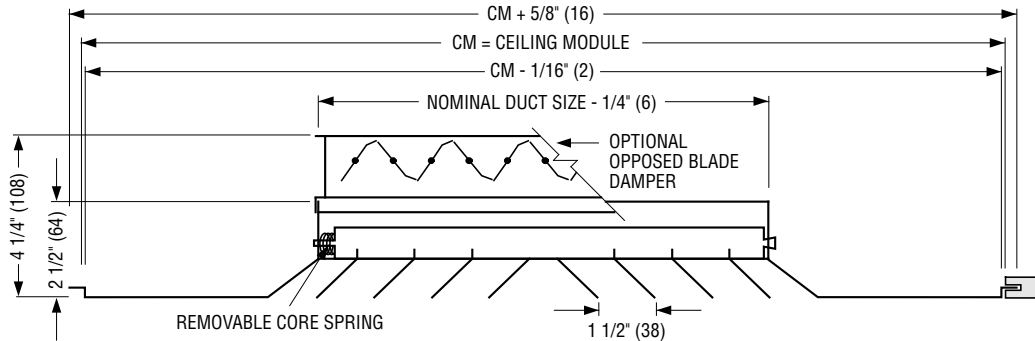

PATTERN CEILING DIFFUSERS
ALUMINUM • SQUARE, RECTANGULAR OR
ROUND NECK
MODELS: 6400 AND 6400-O TYPE SP

TYPE SP SPLINE



If the ceiling module is not 3" (76) larger than the neck size of the diffuser in both dimensions, a steel, module sized extended panel will be added.
 Minimum duct size: 6 x 6 (152 x 152).
 Maximum duct size: see table.
 Available in 3" (76) increments only.

IMPERIAL MODULES				METRIC MODULES	
Imperial Units (in.)		Metric Units (mm)		Metric Units (mm)	
CM	Maximum Duct Size	CM	Maximum Duct Size	CM	Maximum Duct Size
12 x 12	9 x 9	305 x 305	229 x 229	300 x 300	152 x 152
24 x 12	21 x 9	610 x 305	533 x 229	600 x 300	457 x 152
24 x 24	21 x 21	610 x 610	533 x 533	600 x 600	457 x 457

CORE STYLE SELECTION

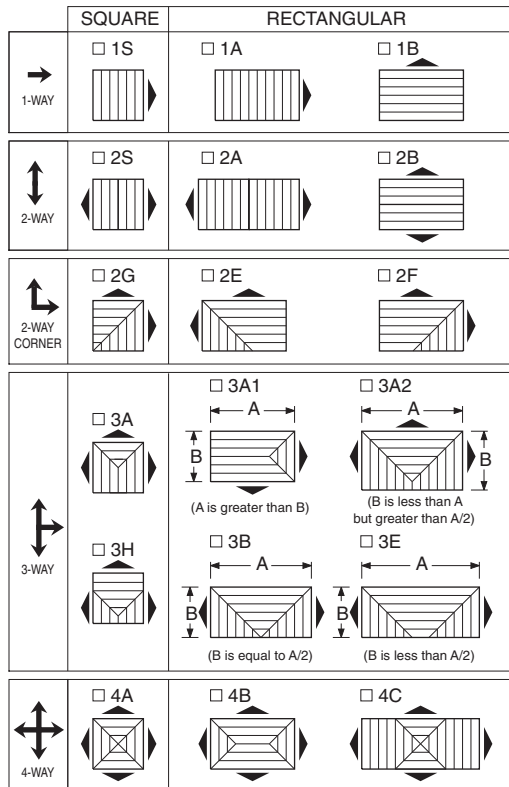

Patterns are shown in plan view (looking down into inlet).

Spline Type Diffuser for one-directional exposed T-bar lay-in grid or for concealed T-bar grid (splines on two opposite sides - steel lift brackets on other two sides).

DESCRIPTION:

1. Material: Aluminum. Extended panel where required is corrosion-resistant coated steel.
2. Model 6400 is an extra high capacity ceiling diffuser available in 1, 2, 3 or 4-way blow patterns. The diffusers are designed to create an induction effect which causes rapid mixing of room air and primary air and reduces discharge velocity. These diffusers rely upon the ceiling coanda effect in order to maintain the horizontal air pattern and catalogued throws. Suitable for normal ceiling heights of 9 – 10 feet.
3. Spring-loaded removable core.
4. Standard finish is AW Appliance White.

OPTIONS:

- PLA Aluminum Extended Panel.
- SQUARE AND RECTANGULAR NECK**
- Steel opposed blade damper. Model 6400-O.
- Aluminum opposed blade damper. Model 6400-OA.

ROUND NECK

- SR Square to round transition collar
- SR-O Square to round transition collar for use over O.B.D.
- 4275 Radial Opposed Blade Damper (round)
- 4250 Radial Sliding Blade Damper (round)
- 4675 Butterfly Damper (round)

EXTERNAL INSULATION

- EX External Foil-Back Insulation, installed-R-4.2.

OPTIONAL FINISH:

- SP Special. Specify _____.

SCHEDULE TYPE:

PROJECT:

ENGINEER:

CONTRACTOR:

Dimensions are in inches (mm).

DATE	B SERIES	SUPERSEDES	DRAWING NO.
2 - 8 - 18	6400	11 - 24 - 16	6400-3