

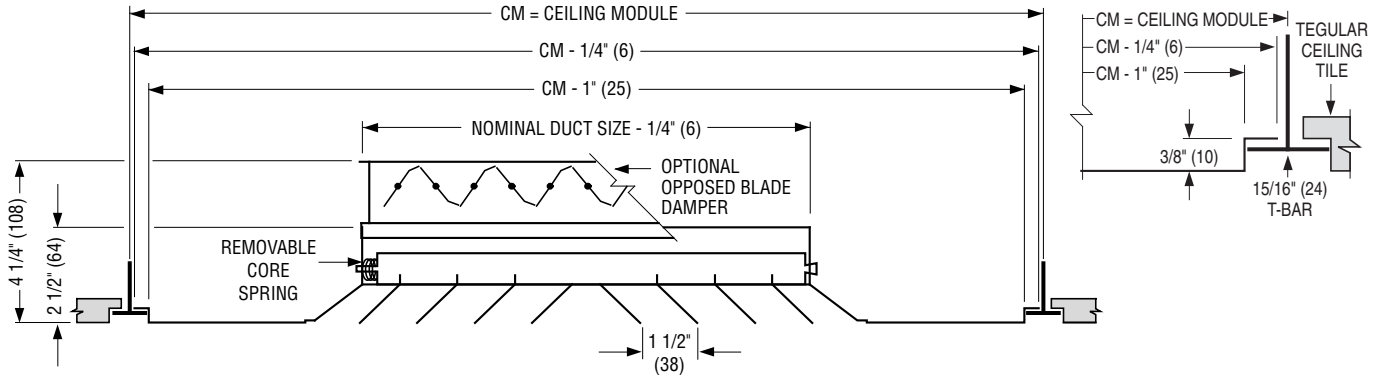

**PATTERN CEILING DIFFUSERS**  
**ALUMINUM • SQUARE, RECTANGULAR OR**  
**ROUND NECK**  
**MODELS: 6400 AND 6400-O TYPE TL**

**TYPE TL TEGULAR LAY-IN**



Minimum duct size: 6 x 6 (152 x 152).  
 Maximum duct size: see table.  
 Available in 3" (76) increments only.

IMPERIAL MODULES				METRIC MODULES	
Imperial Units (in.)		Metric Units (mm)		Metric Units (mm)	
CM	Maximum Duct Size	CM	Maximum Duct Size	CM	Maximum Duct Size
12 x 12	6 x 6	305 x 305	152 x 152	300 x 300	152 x 152
24 x 12	18 x 6	610 x 305	457 x 152	600 x 300	457 x 152
24 x 24	18 x 18	610 x 610	457 x 457	600 x 600	457 x 457

**CORE STYLE SELECTION**

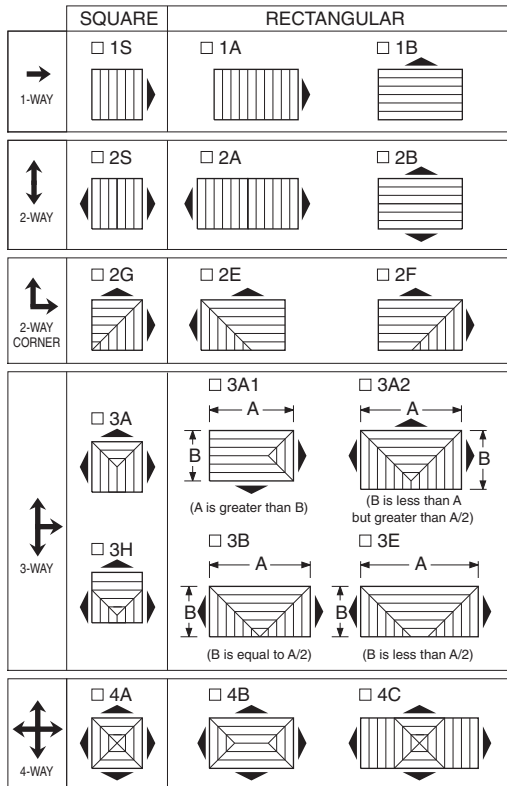

Patterns are shown in plan view (looking down into inlet).

**DESCRIPTION:**

1. Material: Aluminum. Extended panel where required is corrosion-resistant coated steel.
2. Model 6400 is an extra high capacity ceiling diffuser available in 1, 2, 3 or 4-way blow patterns. The diffusers are designed to create an induction effect which causes rapid mixing of room air and primary air and reduces discharge velocity. These diffusers rely upon the ceiling coanda effect in order to maintain the horizontal air pattern and catalogued throws. Suitable for normal ceiling heights of 9 – 10 feet.  
 The diffuser is supplied in a module sized extended panel which drops the diffuser face below the T-bar so that it is flush with the tegular ceiling panels.

3. Spring-loaded removable core.
4. Standard finish is AW Appliance White.

**OPTIONS:**

- PLA Aluminum Extended Panel.
- SQUARE AND RECTANGULAR NECK**
- Steel opposed blade damper. Model 6400-O.
- Aluminum opposed blade damper. Model 6400-OA.

**ROUND NECK**

- SR Square to round transition collar
- SR-O Square to round transition collar for use over O.B.D.
- 4275 Radial Opposed Blade Damper (round)
- 4250 Radial Sliding Blade Damper (round)
- 4675 Butterfly Damper (round)

**EXTERNAL INSULATION**

- EX External Foil-Back Insulation, installed -R-4.2.
- MIB Molded Insulation Blanket, -R-6.0. ('MIB' is available for Frame Types L, TL and F with a 24 x 24 CM only, 15 x 15 max. neck size and a 'SR' square-to-round transition collar).

**OPTIONAL FINISH:**

- SP Special. Specify \_\_\_\_\_.

<b>SCHEDULE TYPE:</b>		Dimensions are in inches (mm).			
<b>PROJECT:</b>					
<b>ENGINEER:</b>	<b>DATE</b>	<b>B SERIES</b>	<b>SUPERSEDES</b>	<b>DRAWING NO.</b>	
<b>CONTRACTOR:</b>	1 - 16 - 17	6400	8 - 17 - 16	6400-5	