

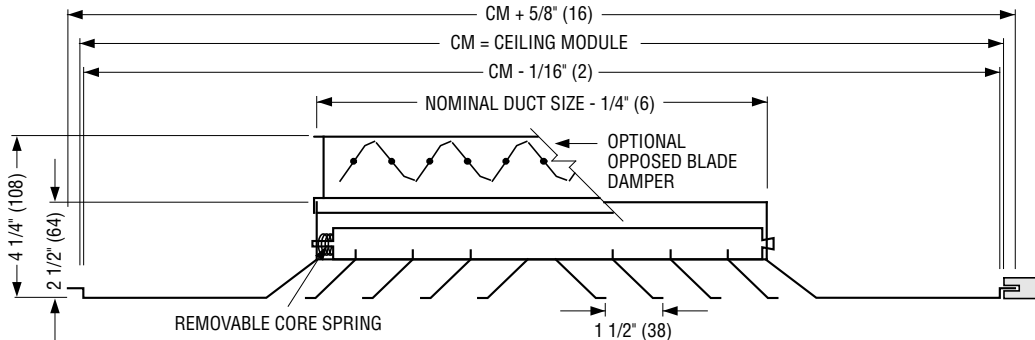

PATTERN CEILING DIFFUSERS
STEEL • SQUARE, RECTANGULAR OR
ROUND NECK
MODELS: 6500 AND 6500-O TYPE SP

TYPE SP SPLINE



If the ceiling module is not 3" (76) larger than the neck size of the diffuser in both dimensions, a module sized extended panel will be added.

Minimum duct size: 6 x 6 (152 x 152).

Maximum duct size: see table.

Available in 3" (76) increments only.

IMPERIAL MODULES				METRIC MODULES	
Imperial Units (in.)		Metric Units (mm)		Metric Units (mm)	
CM	Maximum Duct Size	CM	Maximum Duct Size	CM	Maximum Duct Size
12 x 12	9 x 9	305 x 305	229 x 229	300 x 300	152 x 152
20 x 20	15 x 15	508 x 508	381 x 381	500 x 500	381 x 381
24 x 12	21 x 9	610 x 305	533 x 229	600 x 300	457 x 152
24 x 24	21 x 21	610 x 610	533 x 533	600 x 600	457 x 457
48 x 24	45 x 21	1219 x 610	1143 x 533	1200 x 600	1067 x 457

CORE STYLE SELECTION

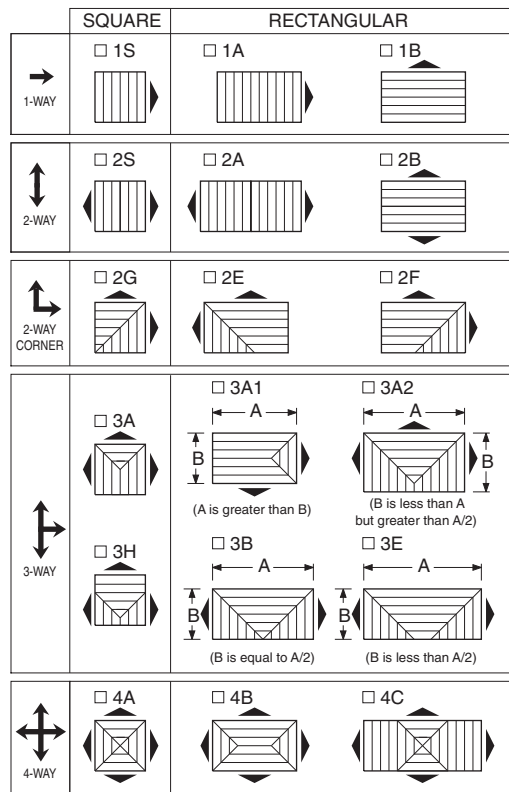

Patterns are shown in plan view (looking down into inlet).

Spline Type Diffuser for one-directional exposed T-bar lay-in grid or for concealed T-bar grid (splines on two opposite sides - steel lift brackets on other two sides).

DESCRIPTION:

1. Material: Corrosion-resistant steel.
2. Model 6500 is a high capacity ceiling diffuser available in 1, 2, 3 or 4-way blow patterns to provide a tight horizontal airflow pattern from maximum to minimum airflow. Ideal for VAV applications.
3. Spring-loaded removable core.
4. Standard finish is AW Appliance White.

OPTIONS:

SQUARE AND RECTANGULAR NECK

Steel opposed blade damper. Model 6500-O.

ROUND NECK

- SR Square to round transition collar
- SR-O Square to round transition collar for use over O.B.D.
- 4275 Radial Opposed Blade Damper (round)
- 4250 Radial Sliding Blade Damper (round)
- 4675 Butterfly Damper (round)

EXTERNAL INSULATION

EX External Foil-Back Insulation, installed -R-4.2.

OPTIONAL FINISH:

SP Special. Specify _____ .

SCHEDULE TYPE:	Dimensions are in inches (mm).			
PROJECT:				
ENGINEER:	DATE	B SERIES	SUPERSEDES	DRAWING NO.
CONTRACTOR:	2 - 8 - 18	6500	11 - 24 - 16	6500-4