

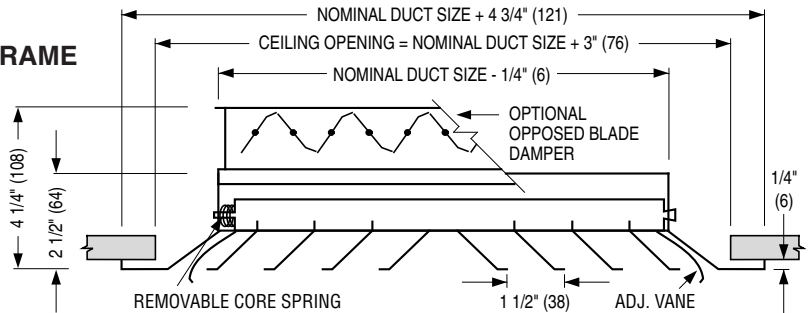

PATTERN CEILING DIFFUSERS
ADJUSTABLE VANES • STEEL
• SQUARE OR ROUND NECK
MODELS: 6550 AND 6550-O TYPES S & B

TYPE S • SURFACE MOUNT • FLAT FRAME

Minimum duct size: 6 x 6 (152 x 152)
 Maximum duct size: 24 x 24 (610 x 610)
 Available in 3" (76) increments only.



TYPE B • BEVELED DROP FACE
• SURFACE MOUNT

Minimum duct size: 6 x 6 (152 x 152)
 Maximum duct size: 24 x 24 (610 x 610)
 Available in 3" (76) increments only.

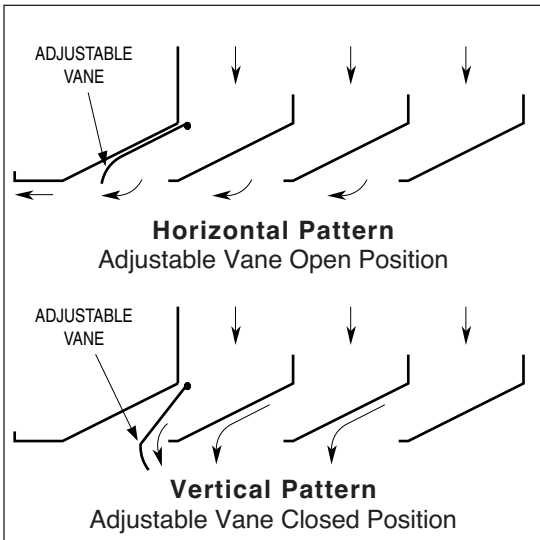
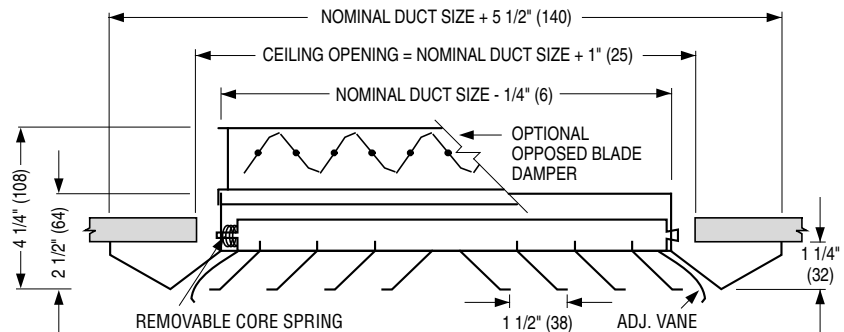

DESCRIPTION:

1. Material: Corrosion-resistant steel.
2. Model 6550 is a high capacity ceiling diffuser available with a square 4-way blow pattern as standard (optional core styles are available). The unit is supplied with independent movable vanes on all four sides to provide a horizontal to vertical throw adjustable discharge. In the horizontal setting, the diffuser provides a tight horizontal airflow pattern from maximum to minimum airflow. Ideal for VAV applications.
3. Spring-loaded removable core.
4. Standard finish is AW Appliance White.

OPTIONS:

SQUARE AND RECTANGULAR NECK

Steel opposed blade damper. Model 6550-O.

ROUND NECK

- SR Square to round transition collar
- SR-O Square to round transition collar for use over O.B.D.
- 4275 Radial Opposed Blade Damper (round)
- 4250 Radial Sliding Blade Damper (round)
- 4675 Butterfly Damper (round)

EXTERNAL INSULATION

EX External Foil-Back Insulation, installed -R-4.2.

OPTIONAL FINISH:

SP Special. Specify _____ .

SCHEDULE TYPE:		Dimensions are in inches (mm).			
PROJECT:					
ENGINEER:	DATE	B SERIES	SUPERSEDES	DRAWING NO.	
CONTRACTOR:	11 - 24 - 16	6550	5 - 11 - 15	6550-1	