

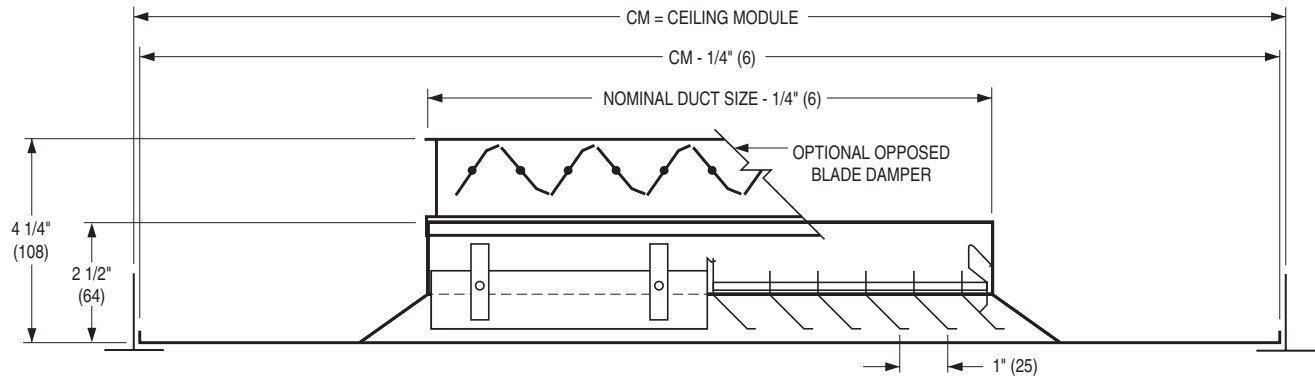

MODULAR CORE CEILING DIFFUSER
 1, 2, 3 OR 4-WAY ADJUSTABLE DISCHARGE
 PATTERN • SQUARE NECK • ALUMINUM
 MODELS: 7200 AND 7200-O TYPE L

TYPE L LAY-IN T-BAR



If the ceiling module is more than 3" (76) larger than the neck size of the diffuser, a steel, module sized extended panel will be added.

Ceiling Module CM			Available Duct Sizes		
Imperial Modules		Metric Modules			
Imperial Units (inches)	SI Units (mm)	SI Units (mm)			
12 x 12	305 x 305	300 x 300	6 x 6 (152 x 152)	8 x 8 (203 x 203)	
24 x 12	610 x 305	600 x 300			
20 x 20	508 x 508	500 x 500	6 x 6 (152 x 152)	10 x 10 (254 x 254)	14 x 14 (356 x 356)
			8 x 8 (203 x 203)	12 x 12 (305 x 305)	
24 x 24	610 x 610	600 x 600	6 x 6 (152 x 152)	12 x 12 (305 x 305)	16 x 16 (406 x 406)
			8 x 8 (203 x 203)	14 x 14 (356 x 356)	
			10 x 10 (254 x 254)	18 x 18 (457 x 457)	

DESCRIPTION:

1. Material: Aluminum. Extended panel where applicable is corrosion-resistant steel.
2. Model 7200 is a versatile ceiling diffuser. It consists of four spring loaded modular cores that may be simply adjusted by rotating each module after installation to provide a 1, 2, 3 or 4-way blow pattern. A tight horizontal air pattern from maximum to minimum flow makes it ideal for VAV applications.
3. Standard finish is AW Appliance White.

OPTIONS:

- PLA Aluminum Extended Panel
- SQUARE NECK**
- Steel opposed blade damper - Model 7200-O
 - Aluminum opposed blade damper - Model 7200-OA
- ROUND NECK**
- SQR Square to round transition collar
 - SQR-O Square to round transition collar for use over opposed blade damper.
- _____ round neck size (inches)
- 4275 Radial damper
 - 4250 Radial sliding blade damper
 - 4675 Butterfly damper
- OPTIONAL FINISH:**
- SP Special. Specify _____ .

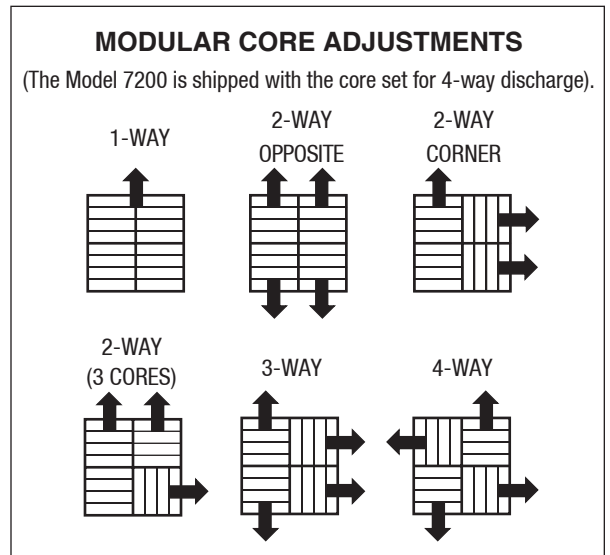

SCHEDULE TYPE:

PROJECT:

ENGINEER:

CONTRACTOR:

Dimensions are in inches (mm).

DATE	B SERIES	SUPERSEDES	DRAWING NO.
9 - 8 - 21	7200	1 - 20 - 16	7200-2