

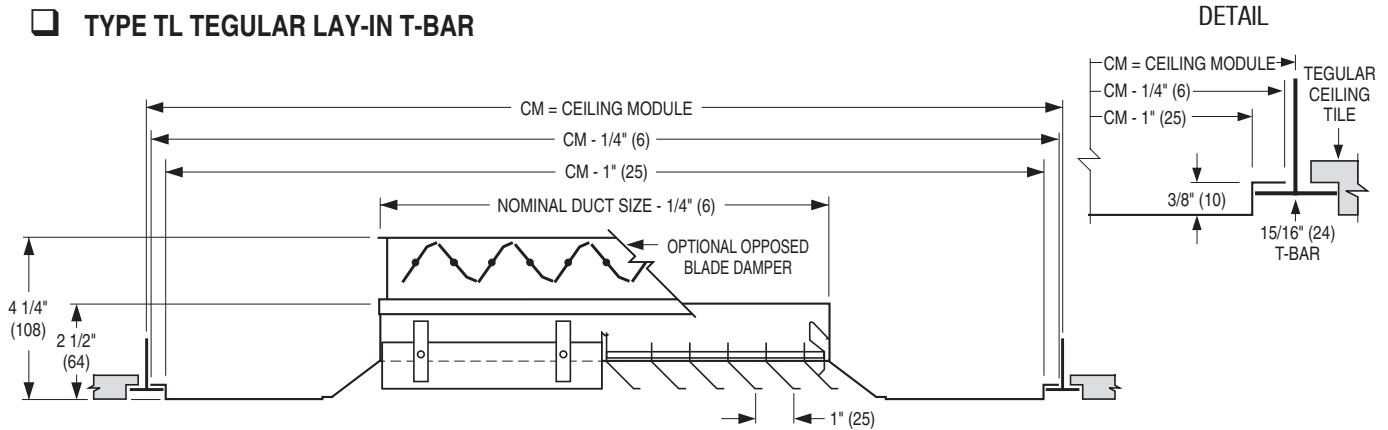

**MODULAR CORE CEILING DIFFUSER**  
 1, 2, 3 OR 4-WAY ADJUSTABLE DISCHARGE  
 PATTERN • SQUARE NECK • ALUMINUM  
 MODELS: 7200 AND 7200-O TYPE TL

TYPE TL TEGULAR LAY-IN T-BAR



Ceiling Module CM			Available Duct Sizes		
Imperial Modules		Metric Modules			
Imperial Units (inches)	SI Units (mm)	SI Units (mm)			
12 x 12	305 x 305	300 x 300	6 x 6 (152 x 152)		
24 x 12	610 x 305	600 x 300			
20 x 20	508 x 508	500 x 500	6 x 6 (152 x 152)	10 x 10 (254 x 254)	14 x 14 (356 x 356)
			8 x 8 (203 x 203)	12 x 12 (305 x 305)	
24 x 24	610 x 610	600 x 600	6 x 6 (152 x 152)	12 x 12 (305 x 305)	16 x 16 (406 x 406)
			8 x 8 (203 x 203)	14 x 14 (356 x 356)	18 x 18 (457 x 457)
			10 x 10 (254 x 254)		

**DESCRIPTION:**

1. Material: Aluminum. Extended panel where required is corrosion-resistant steel.
2. Model 7200 is a versatile ceiling diffuser. It consists of four spring loaded modular cores that may be simply adjusted by rotating each module after installation to provide a 1, 2, 3 or 4-way blow pattern. A tight horizontal air pattern from maximum to minimum flow makes it ideal for VAV applications.
3. Standard finish is AW Appliance White.

**OPTIONS:**

- PLA Aluminum Extended Panel
- SQUARE NECK**
- Steel opposed blade damper - Model 7200-O
- Aluminum opposed blade damper - Model 7200-OA
- ROUND NECK**
- SQR Square to round transition collar
- SQR-O Square to round transition collar for use over opposed blade damper. \_\_\_\_ round neck size (inches)
- 4275 Radial damper
- 4250 Radial sliding blade damper
- 4675 Butterfly damper
- OPTIONAL FINISH:**
- SP Special. Specify \_\_\_\_\_ .

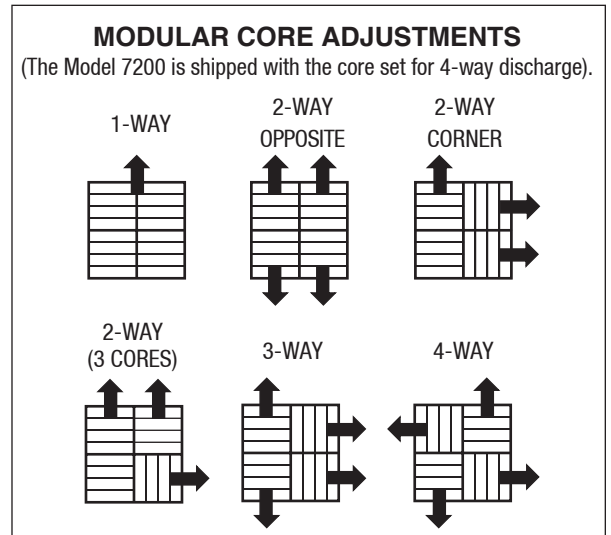

<b>SCHEDULE TYPE:</b>	Dimensions are in inches (mm).			
<b>PROJECT:</b>				
<b>ENGINEER:</b>	<b>DATE</b>	<b>B SERIES</b>	<b>SUPERSEDES</b>	<b>DRAWING NO.</b>
<b>CONTRACTOR:</b>	9 - 8 - 21	7200	3 - 1 - 16	7200-3C