

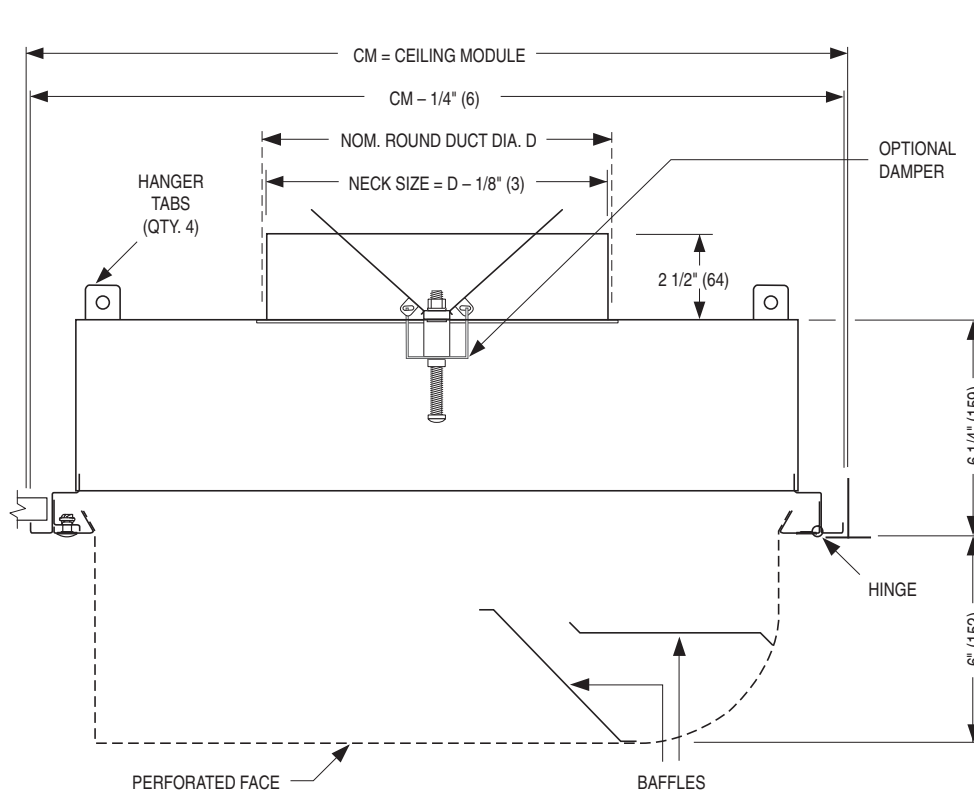

RADIAL PATTERN DIFFUSER
 90 DEGREE • STAINLESS STEEL
 CRITICAL ENVIRONMENT APPLICATIONS
 PERFORATED FACE
MODEL: 92RPD-1SS

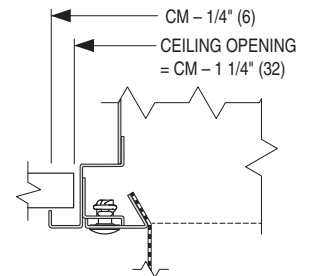

TYPE S Surface Mount Detail



TYPE L* Lay-in T-Bar Detail

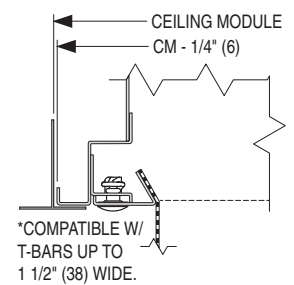

Ceiling Module Sizes

| Imperial Modules | | Metric Modules | | | |
|-------------------------|---------|-----------------|------------|-----------------|------------|
| Imperial Units (inches) | | S.I. Units (mm) | | S.I. Units (mm) | |
| D | CM | D | CM | D | CM |
| 8 | 48 x 12 | 203 | 1219 x 305 | 203 | 1200 x 300 |
| 8, 10 | 24 x 24 | 203, 254 | 610 x 610 | 203, 254 | 600 x 600 |
| 10, 12 | 48 x 24 | 254, 305 | 1219 x 610 | 254, 305 | 1200 x 600 |

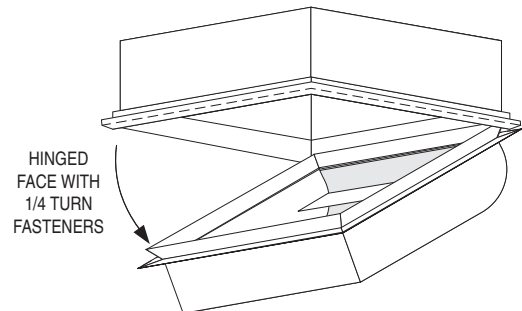

DESCRIPTION:

The Model 92RPD-1SS Radial Pattern Diffuser has been designed to provide low aspiration and high ventilation rates especially for clean room applications such as research laboratories, animal labs, food processing, hospital rooms and computer rooms. The unique design of solid baffles in an intrusive perforated face can handle large volumes of air with low initial face velocities. The 92RPD-1SS introduces air in a 90 degree radial flow pattern, flushing a room with large volumes of clean conditioned air, minimizing entrainment and hence mixing with contaminated air while still allowing low room air velocities.

CONSTRUCTION:

- 304 Stainless Steel perforated face with 3/32" (2.4) dia. holes on 60 degree 1/4" (6) staggered centers (13% free area). The face of the diffuser is attached to the plenum with stainless steel hinges. The opposite side is secured with 1/4 turn fasteners. The diffuser face simply hinges down for easy access to the interior for cleaning.
- 304 Stainless Steel fully welded plenum and baffles.
- Standard finish is #4 Brushed Satin Polish.

OPTIONS:

- 316 Stainless Steel construction.
 - BDS Butterfly damper, Stainless Steel (face operated).
- Finish:
- AW Appliance White.
 - SP Special _____ .

| | | | | |
|-----------------------|--------------------------------|-----------------|-------------------|--------------------|
| SCHEDULE TYPE: | Dimensions are in inches (mm). | | | |
| PROJECT: | | | | |
| ENGINEER: | DATE | B SERIES | SUPERSEDES | DRAWING NO. |
| CONTRACTOR: | 9 - 2 - 16 | 9200-SS | 12 - 12 - 11 | 92RPD-1SS |