



**AIR BALANCING DEVICE • RADIAL OPPOSED  
BLADE DAMPER WITH OPERATOR ARM  
STEEL • (UNI DIFFUSER OPTION)  
MODEL: 4275-OA (5" - 15" DIA.)**

**DESCRIPTION:**

A unique method of controlling volume through a diffuser providing premium design quality and performance. The multi-blade perimeter design offers true radial flow at any setting.

**Model 4275-OA** has an operator arm (shown) which allows damper adjustment on the **UNI Diffusers** without removing the inner cone assembly. (Size 10 through 15 have a double operator arm).

The damper is designed to fit directly on the neck of the diffuser. Simple convenient and accurate installation and operation.

**OPERATION:**

Size 5 through 8 are friction type. Turn operator arm to adjust damper setting.

Size 10 through 15 use a detent mechanism to positively hold damper setting. Lift up and turn operator to desired damper setting.

1. Material: Corrosion-resistant steel construction.
2. Damper mounts directly to diffuser collar.
3. Standard Finish: Mill.

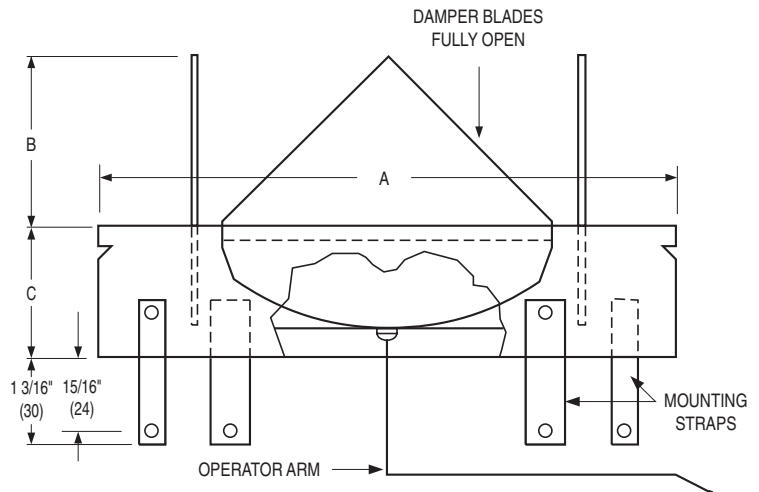
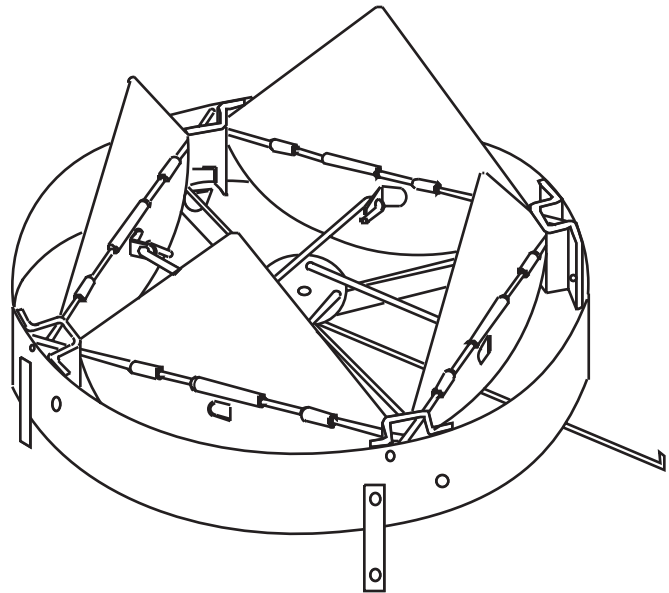

	Nominal Size (inches)							Nominal Size (mm)						
	5	6	8	10	12	14	15	127	152	203	254	305	356	381
A	4 7/8	5 7/8	7 7/8	9 7/8	11 7/8	13 7/8	14 7/8	124	149	200	251	302	352	378
B	1 1/8	1 5/8	2 1/2	2 1/4	2 7/8	3 3/8	3 3/4	29	41	64	57	73	86	95
C	1 5/8			2 1/2				41			64			

**SCHEDULE TYPE:**

**PROJECT:**

**ENGINEER:**

**CONTRACTOR:**

Dimensions are in inches (mm).

**DATE**

**B SERIES**

**SUPERSEDES**

**DRAWING NO.**

3 - 1 - 02

ABD

10 - 26 - 01

ABD-42750A