

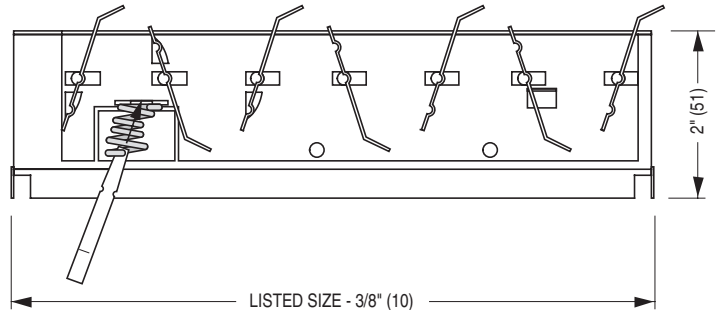

AIR BALANCING DEVICES
OPPOSED BLADE DAMPER • STEEL • NECK
MOUNTED FOR SQUARE AND RECTANGULAR NECKS
MODEL: OBD TYPE DL & GL

TYPE DL Lever Operator

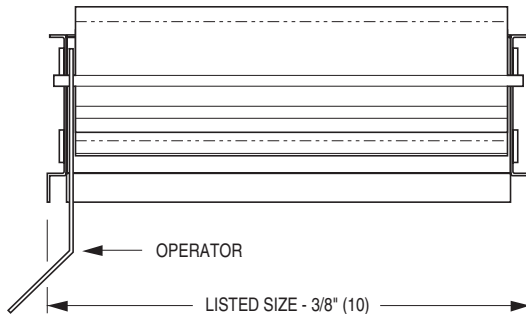

- OBD-L** Long Blades (parallel to long dimension)
- OBD-S** Short Blades (parallel to short dimension)

Minimum Size = 6" x 4" (152 x 102)
 Maximum Size = 24" x 24" (610 x 610)

DESCRIPTION:

1. Material: Roll-formed, corrosion-resistant steel. Mill finish.
2. Type DL designed to mount directly on the neck of Nailor 6500, 6400 and 6200 Series Pattern Diffusers in square and rectangular neck applications. Supplied with steel barbed S-clips for easy field mounting. Type DL operating lever is accessible from the face side of the diffuser and permits balancing without removing the diffuser inner core assembly.
3. Gang operated blades on 1" (25) centers move simultaneously in opposite directions and close at 45° to permit precise metering of the air with a minimal disturbance to the air pattern.

OPTIONS:

- Type GL** Lever Operator
 Similar in design except operator handle is straight. May be used on angled deflection 5100, 6100 and 7100 Series Return Grilles and 4900 Series Linear Bar Grilles. When used on linear bar grilles, dampers are sized: Nominal – 1/2" (13). In all cases; specify grille model. Blade orientation of damper must be opposite of grille. Grille Model _____.

SPECIAL FEATURES:

_____.

SCHEDULE TYPE:		Dimensions are in inches (mm).			
PROJECT:					
ENGINEER:	DATE	B SERIES	SUPERSEDES	DRAWING NO.	
CONTRACTOR:	8 - 11 - 20	ACC.DIF/GR	10 - 9 - 99R	ACC.ABD-6	