



ALUMINUM FLOOR ACCESS OUTLET
FOR ELECTRICAL AND COMMUNICATION CABLE ROUTING
UNDERFLOOR AIR DISTRIBUTION SYSTEMS
MODEL: ANFA • SIZE 10

DESCRIPTION:

The Nailor ANFA Floor Access Outlet is for use in raised access floor air distribution systems. It is designed to complement the model ANFD Floor "Swirl" Diffuser.

The ANFA is an architecturally pleasing and functional means for providing through the floor routing of electrical, telephone and data communication cables.

FEATURES:

- **Meets all requirements of NFPA 90A.**
- Cast aluminum construction.
- Nominal size 10" (254) dia.
- Three grommet holes will each accept cables or conduit up to 1 1/4" (32) dia. Heavy duty grommet seals (EPFI closed cell foam) prevent air leakage.
- Removable cover plate features a tamper-proof locking mechanism to prevent unwanted removal.
- Architecturally appealing face design compliments contemporary decor.
- Rugged trim ring design secures carpet and prevents edges from fraying.
- Unique adjustable mounting clamp design adapts to any floor panel thickness and provides simple and secure installation. Permits installation from above the floor without removal of the floor panel or carpet.
- A PVC ribbed Press Fit Gasket is also available as a "labor saving" mounting option.
- Standard finish is textured GRT Gray or BKT Black.

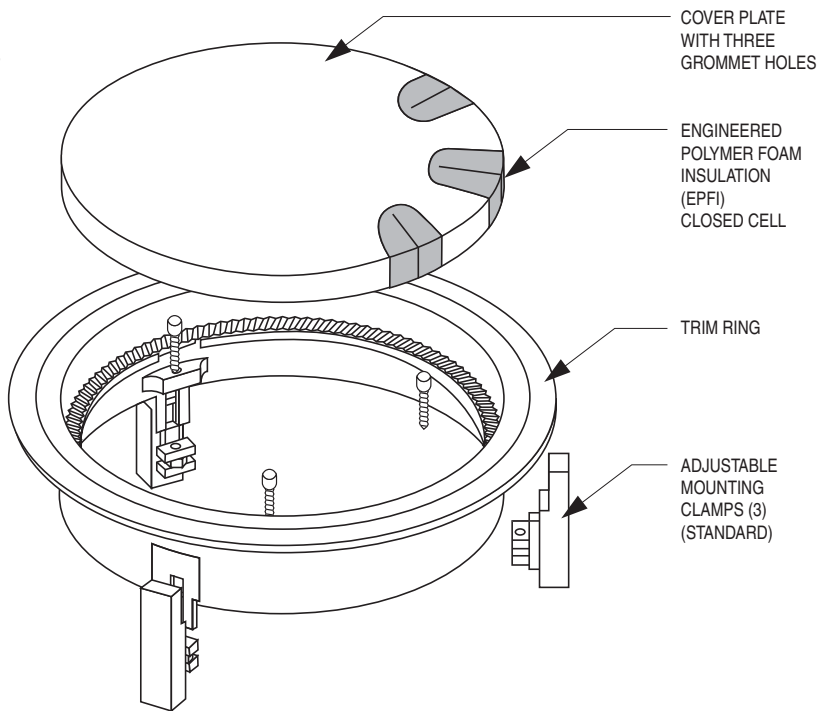

PRECISION FLOOR OPENING DIAMETER

MC Mounting Clamps = 10 7/16" (265)
 PFG Press Fit Gasket = 10 9/16" (268)

SELECTION:

1. Mounting:
 - MC Mounting Clamps (standard)
 - PFG Press Fit Gasket (optional)
2. Finish:
 - GRT Gray
 - BKT Black
 - SPT Special (custom color by architect)
Specify _____ .

SCHEDULE TYPE:		Dimensions are in inches (mm).			
PROJECT:					
ENGINEER:	DATE	B SERIES	SUPERSEDES	DRAWING NO.	
CONTRACTOR:	2 - 10 - 11	ANFA	NEW	ANFA-1	