

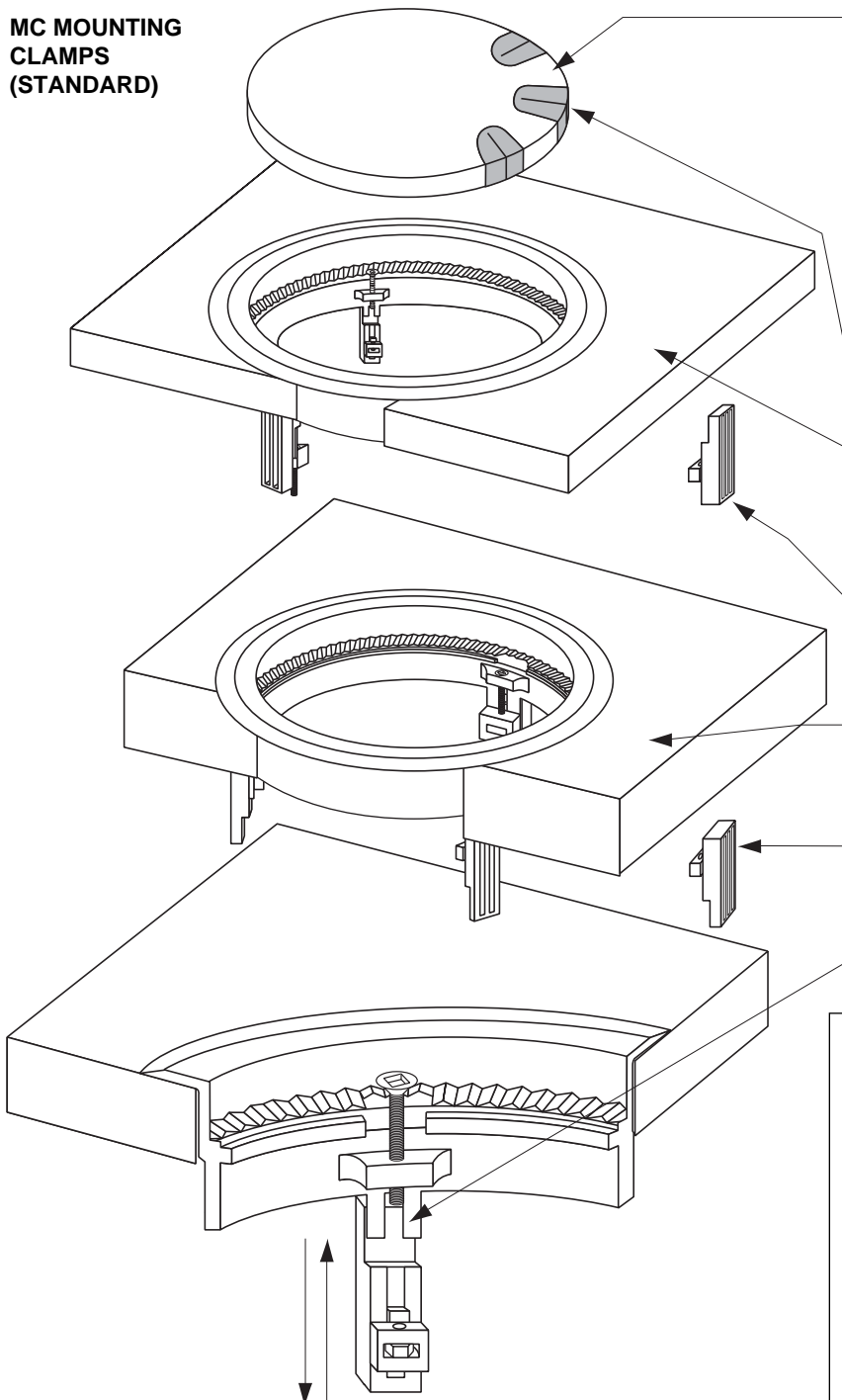

ALUMINUM FLOOR ACCESS OUTLET
INSTALLATION INSTRUCTIONS
FASTENING: MC OR PFG
MODEL: ANFA • SIZE 10

MC MOUNTING CLAMPS (STANDARD)



ACCESS OUTLET COVER PLATE
 ALIGN THE THREE LUGS ON THE UNDERSIDE OF THE COVER PLATE WITH THE THREE OPENINGS IN THE TRIM RING LEDGE AND LOWER INTO PLACE. AFTER TRIM RING INSTALLATION, ROTATE COVER PLATE COUNTER-CLOCKWISE UNTIL DETENT BUTTON LOCATES IN TRIM RING HOLE AND LOCKS IN PLACE.

REMOVAL:
 INSERT SMALL FLAT BLADE SCREWDRIVER IN NARROW SLOT IN TRIM RING FLANGE WHERE DETENT BUTTON IS LOCATED AND DEPRESS. ROTATE COVER PLATE CLOCKWISE UNTIL IT HITS THE STOP; LIFT AND REMOVE.

ENGINEERED POLYMER FOAM INSULATION (EPFI). CLOSED CELL

TRIM RING ASSEMBLY OPTION 1 WHEN FLOOR IS 1/4" (6) – 1 1/2" (38)

INSTALL THE THREE MOUNTING CLAMPS WITH THE LONG EXTENSION FACING UPWARDS.

ASSEMBLY OPTION 2 WHEN FLOOR IS 1 1/2" (38) – 2" (51)

INSTALL THE THREE MOUNTING CLAMPS WITH THE SHORT EXTENSION FACING UPWARDS.

DETAIL OF 1ST ASSEMBLY OPTION

PFG PRESS FIT GASKET (OPTIONAL)

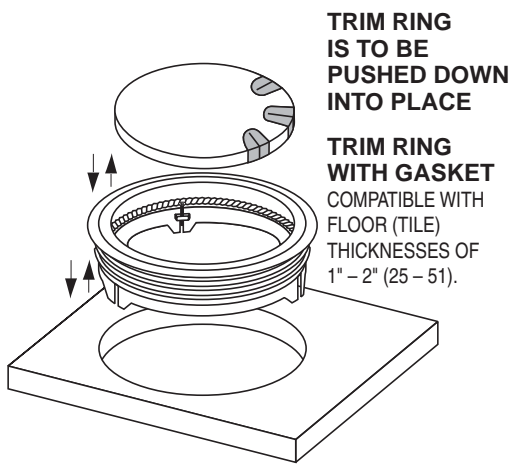

TRIM RING IS TO BE PUSHED DOWN INTO PLACE

TRIM RING WITH GASKET COMPATIBLE WITH FLOOR (TILE) THICKNESSES OF 1" – 2" (25 – 51).

PRECISION FLOOR OPENING DIAMETER

MC Mounting Clamps = 10 7/16" (265)
 PFG Press Fit Gasket = 10 9/16" (268)

Dimensions are in inches (mm).

SCHEDULE TYPE:
PROJECT:
ENGINEER:
CONTRACTOR:

DATE	B SERIES	SUPERSEDES	DRAWING NO.
2 - 10 - 11	ANFA	NEW	ANFA-2