



DYNAMIC INTEGRAL SLEEVE CURTAIN TYPE FIRE DAMPER
 1 1/2 HR. LABEL
 VERTICAL OR HORIZONTAL MOUNT
 FOR USE IN DYNAMIC OR STATIC SYSTEMS
 MODEL: D0114-1X (TYPE A)



QUALIFICATIONS:

- **UL 555 & CAN/ULC-S112 CLASSIFIED DYNAMIC FIRE DAMPER.** 1 1/2 hr. label (File # R9492).
- **Meets all the requirements of UL and NFPA 80, 90A and 101 for fire dampers in dynamic HVAC systems, as well as IBC and NBC (Canada) Building Code requirements.**
- **City of New York Board of Standards and Appeals. Cal. No. 460-88-SA.**
- **California State Fire Marshal: Fire Damper Listing No. 3225-0935:0113.**
- **Maximum velocity: 4000 fpm @ 4" w.g. (20 m/s @ 1 kPa).**

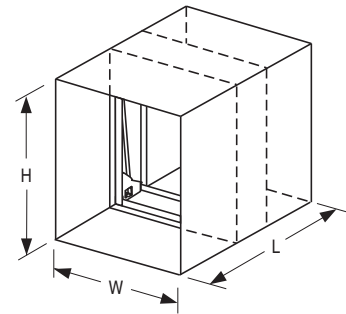

Type A – Blades and frame in the airstream.

Model Series D0114-1X curtain fire dampers are UL approved for use where local building codes require the protection of HVAC ductwork penetrations in walls, partitions or floors that have a fire resistance rating of up to 2 hours. Classified for use in dynamic "fans on" systems where the HVAC system remains operative in the event of a fire, damper closure under airflow is assured.

Integral sleeve fire dampers offer convenience and labor savings. The costly requirement to field or shop fabricate custom sleeves is eliminated and dampers can therefore ship directly from the manufacturer to the job site – saving time and money.

Optional "Quick-Set" retaining angles complete the installation package. Factory fabricated, sized and shipped with damper, they install quickly, provide further labor savings and eliminate the need for any field fabrication.

STANDARD CONSTRUCTION:

Integral 22 ga. (0.85) roll-formed G60 galvanized steel.

Sleeve/Frame: D0114 - 12 Length 12" (305)
 D0114 - 14 Length 14" (356)
 D0114 - 16 Length 16" (406)

Blades: Curtain type interlocking blades, 22 ga. (0.85) roll-formed G60 galvanized steel.

Fusible Link: 165°F (74°C) standard. UL Listed. 212°F (100°C) available.

Blade Closure: Stainless steel closure springs and galvanized steel locking ramps.

Sizes (Duct W x H):

Model Type	Velocity/Pressure Rating	Single Section			
		Minimum		Maximum	
		Vertical	Horizontal	Vertical	Horizontal
D0114-12/14/16	24	6" x 6" (152 x 152)	6" x 6" (152 x 152)	36" x 36" (914 x 914)	24" x 24" (610 x 610)
	34, 44	6" x 6" (152 x 152)	—	24" x 24" (610 x 610)	—

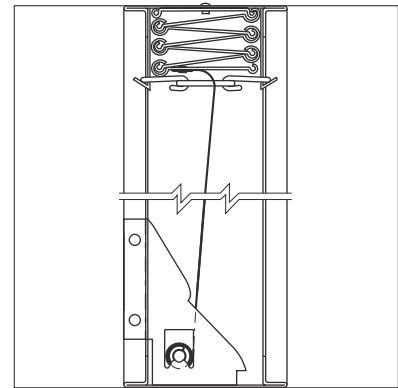

VERTICAL MOUNT

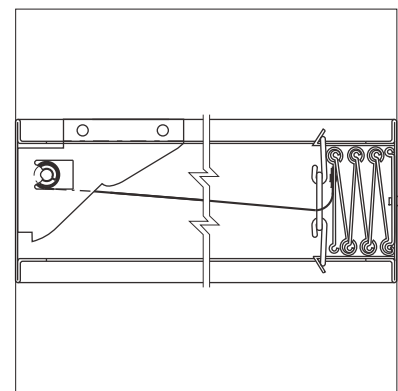

HORIZONTAL MOUNT

OPTIONS:

- Non-standard temperature fusible link. Specify _____.
- PT** Pull Tab Release. Permits simple reset of horizontal damper when access door is located below damper. (See dwg. ACC-PTR for details).
- QS1** Quick-set retaining angles (single set).
- QS2** Quick-set retaining angles (pair).

DYNAMIC VELOCITY/PRESSURE RATING:

- 24** 2000 fpm @ 4" w.g. (Standard)
- 34** 3000 fpm @ 4" w.g. } (Optional)
- 44** 4000 fpm @ 4" w.g. }

SCHEDULE TYPE:

PROJECT:

ENGINEER:

CONTRACTOR:

For installation instructions, see IOM-FDINST.
 Dimensions are in inches (mm).

DATE	B SERIES	SUPERSEDES	DRAWING NO.
3 - 28 - 18	FD	4 - 28 - 14	D0100-5A