



DYNAMIC CURTAIN TYPE FIRE DAMPER
3 HR. LABEL • VERTICAL OR HORIZONTAL
FOR USE IN DYNAMIC OR STATIC SYSTEMS
MODEL: D0530 (TYPES CR & CO)



QUALIFICATIONS:

- **UL 555 & CAN/ULC-S112 CLASSIFIED DYNAMIC FIRE DAMPER.** 3 hr. label (File # R9492).
- **Meets all the requirements of UL and NFPA 80, 90A and 101 for fire dampers in dynamic HVAC systems, as well as IBC and NBC (Canada) Building Code requirements.**
- **City of New York Board of Standards and Appeals. Cal. No. 460-88-SA.**
- **California State Fire Marshal: Fire Damper Listing No. 3225-0935:0113.**
- **Maximum velocity: 4000 fpm @ 4" w.g. (20 m/s @ 1 kPa).**

Model D0530 curtain fire damper is UL approved for use where local building codes require the protection of HVAC ductwork penetrations in walls, partitions or floors that have a fire resistance rating of up to 4 hours. The D0530 is classified for use in dynamic (fans on) systems, where the HVAC system remains operative in the event of a fire. Damper closure under airflow is assured. Type CR round and CO oval fire dampers use transition collars to place the curtain blade pack and damper frame out of the airstream, providing 100% free area.

STANDARD CONSTRUCTION:

- Frame:** 4 1/4" (108) wide, 22 ga. (0.85) roll-formed G60 galv. steel.
Blades: Curtain type interlocking blades, 22 ga. (0.85) roll-formed G60 galvanized steel.
Enclosure: 22 ga. (0.85) galvanized steel.
Fusible Link: 165°F (74°C) standard. UL Listed. 212°F (100°C) available.
Blade Closure: Stainless steel closure springs and galv. steel locking ramps.

Sizes (Duct W x H):

Model Type	Velocity/Pressure Rating	Single Section				Multiple Section	
		Minimum		Maximum		Maximum	
		Vertical	Horizontal	Vertical	Horizontal	Vertical	Horiz.
Round CR	24	4" (102) dia.	4" (102) dia.	31" (787) dia.	20" (508) dia.	① 34" (864) dia.	—
	34, 44	4" (102) dia.	—	20" (508) dia.	—	—	—
Oval CO	24	5" x 4" (127 x 102)	5" x 4" (127 x 102)	34" x 31" (864 x 787)	22" x 20" (559 x 508)	① 70" x 20" (1778 x 508)	—
	34, 44	5" x 4" (127 x 102)	—	22" x 20" (559 x 508)	—	—	—

① Individual sections of multiple section assembly not to exceed 24" (610) in width, up to 48" (1219) wide. Assemblies larger than 48" (1219) in width will be made up of individual sections not to exceed 18" (457) wide.

OPTIONS:

- Non-standard temperature fusible link. Specify _____.
- Factory Sleeve. Available in 10 (3.5) through 22 ga. (0.85) galv. steel and in lengths required for application. Specify: __ length. __ ga.
- LP Unsealed. Suitable for low pressure systems.
- HP Sealed. Suitable for medium/high pressure systems. Externally caulked. (Up to 6 w.g. [1.5 kPa]).

DYNAMIC VELOCITY/PRESSURE RATING:

- 24 2000 fpm @ 4" w.g. (Standard)
- 34 3000 fpm @ 4" w.g. } (Optional)
- 44 4000 fpm @ 4" w.g. }

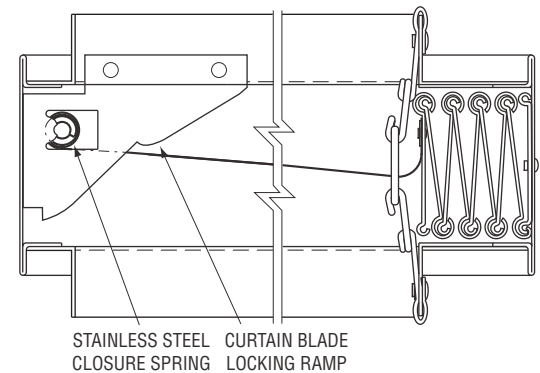
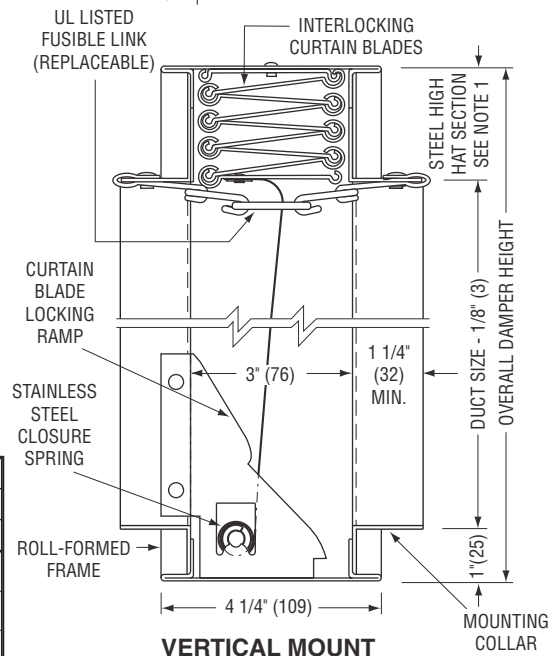
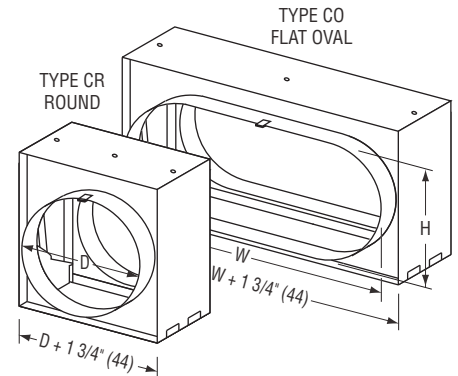

HORIZONTAL MOUNT

NOTES:

1. See sizing chart for relationship of duct size and damper size. Refer to drawings SC1 and SC2.

For installation instructions, see IOM-FDINST.
 Dimensions are in inches (mm).

SCHEDULE TYPE:				
PROJECT:				
ENGINEER:	DATE	B SERIES	SUPERSEDES	DRAWING NO.
CONTRACTOR:	3 - 28 - 18	FD	4 - 28 - 14	D0500-3