



DYNAMIC MULTI-BLADE FIRE DAMPER
 FOR USE IN DYNAMIC OR STATIC SYSTEMS
 1 1/2 HR. LABEL • VEE BLADE
 MODELS: D1250 AND D1251 (TYPE A)



QUALIFICATIONS:

- **UL 555 & CAN/ULC-S112 CLASSIFIED DYNAMIC FIRE DAMPER**
1 1/2 hr. Label (File # R9492).
- **Meets NFPA 80, 90A and 101 as well as IBC and NBC (Canada) Building Code requirements.**
- **City of New York Board of Standards and Appeals. Cal. No. 460-88-SA.**
- **California State Fire Marshal: Fire Damper Listing No. 3225-0935:0101.**
- **Maximum velocity: 4000 fpm @ 4" w.g. (20 m/s @ 1 kPa).**

D1250 Series Dampers are ideal for applications where building codes require a fire damper for the protection of ductwork penetrations in walls or floors that have a fire resistance rating of up to 2 hours. The D1250 Series has been designed and tested to offer a rugged cost effective multi-blade damper well suited to the majority of commercial applications. Parallel blade action assures closure in dynamic (fans on) systems.

The design features the industry proven over-center knee lock with high torque spring/fusible link closure. UL approved for installation with airflow in either direction and inverted mounting supplied as standard with an internal crank arm and locking screw which holds the damper in the fully open position, but may also be used for system balancing if required.

STANDARD CONSTRUCTION:

- Frame:** 5" x 7/8" x 16 ga. (127 x 22 x 1.6) galvanized steel hat channel.
- Blades:** 6" (152) wide on 5 1/2" (140) centers. 16 ga. (1.6) galvanized steel vee groove design. Parallel action.
- Linkage:** Concealed in frame. 12 ga. (2.7) plated steel.
- Bearings:** 1/2" (13) dia. self-lubricating oilite bronze.
- Axles:** 1/2" (13) dia. plated steel bolted to blades.
- Jackshaft:** 1/2" (13) dia. cadmium plated steel.
Internal locking quadrant is factory installed.
- Fusible Link:** 165°F (74°C) standard. 212°F (100°C) available.

Sizes (Duct W x H):

Velocity/ Pressure Rating	Minimum		Maximum			
	Single Sect.	Single Section		Multiple Section		
	Vert./Horiz.	Vertical	Horizontal	Vertical	Horizontal	
24	8" x 8" (203 x 203)	36" x 48" (914 x 1219)	30" x 40" (762 x 1016)	72" x 48" (1829 x 1219) or 36" x 96" (914 x 2438)	60" x 40" (1524 x 1016) or 30" x 80" (762 x 2032).	
34, 44				—	—	

Notes: Dampers with duct heights less than 8" (203) require a Type 'B' sleeve enclosure (Model D1252). Units less than 8" (203) in width only, or in both width and height, require a Type 'C' enclosure (Model D1253).

BASE MODEL SELECTION:

- D1250** Less sleeve
- D1251** Standard factory sleeve 16" long x 20 ga. (406 x 1.0) (18 ga. for dampers over 84" [2134] in width).
- D1251** Non-standard sleeve. Specify _____ length _____ ga. Available up to 36" (914) dependent upon wall thickness and 10 through 20 ga. (3.5 through 1.0).

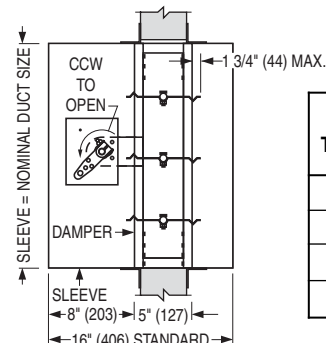
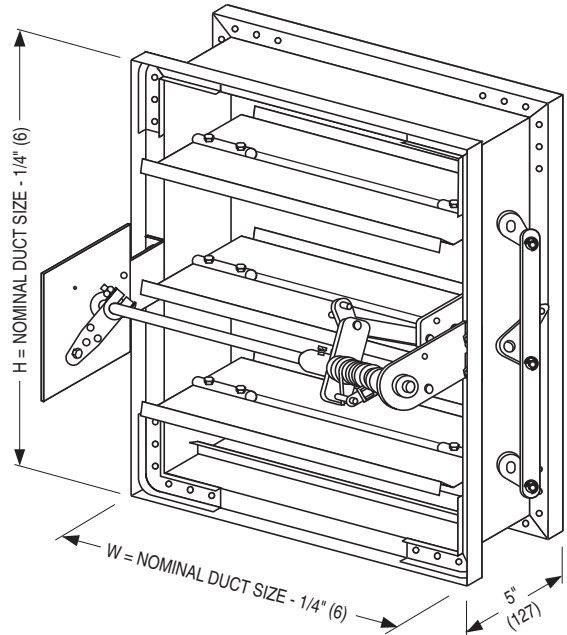

Wall Thickness	Minimum Sleeve Length
4 (102)	16 (406)
8 (203)	20 (508)
12 (305)	24 (610)
16 (406)	28 (711)

DYNAMIC VELOCITY/PRESSURE RATING:

- 24** 2000 fpm @ 4" w.g. (Standard)
- 34** 3000 fpm @ 4" w.g. } (Optional)
- 44** 4000 fpm @ 4" w.g. }

OPTIONS:

- SMP** Side mounting plate
- MLS-300** Position indicator switch package
- QS1** Quick-set retaining angle (one side)
- QS2** Quick-set retaining angles (two sides)
- TDF1** Flange (one end)
- TDF2** Flange (both ends)
- Special features** _____

SCHEDULE TYPE:

PROJECT:

ENGINEER:

CONTRACTOR:

For installation instructions, see IOM-MBFDINST.
 Dimensions are in inches (mm).

DATE	B SERIES	SUPERSEDES	DRAWING NO.
4 - 28 - 14	D1200	11 - 22 - 11	D1250-1