

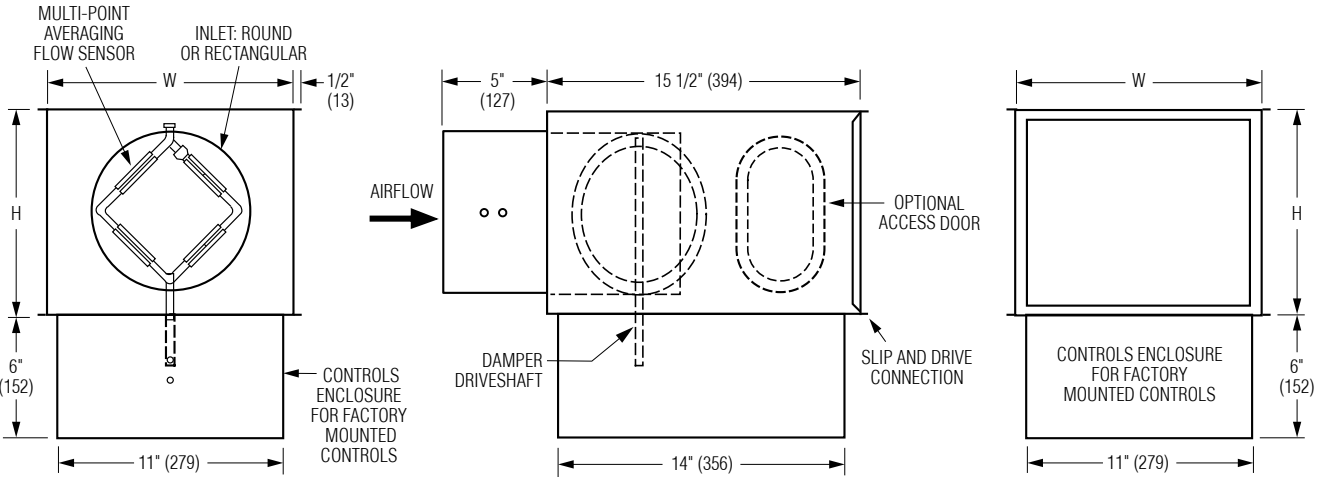

SINGLE DUCT TERMINAL UNIT
 DIGITAL CONTROL • PRESSURE INDEPENDENT
 VARIABLE OR CONSTANT VOLUME
MODEL: D3101 WITH BOTTOM MOUNT CONTROLS
LOCATION (OPTION OB)



Dimensional Data

Unit Size	Airflow Range* cfm (l/s)	W	H	Inlet Size
4	0 – 225 (0 – 106)	12 (305)	8 (203)	3 7/8 (98) Round
5	0 – 400 (0 – 189)	12 (305)	8 (203)	4 7/8 (124) Round
6	0 – 550 (0 – 260)	12 (305)	8 (203)	5 7/8 (149) Round
7	0 – 800 (0 – 378)	12 (305)	10 (254)	6 7/8 (175) Round
8	0 – 1100 (0 – 519)	12 (305)	10 (254)	7 7/8 (200) Round
9	0 – 1400 (0 – 661)	14 (356)	12 1/2 (318)	8 7/8 (225) Round
10	0 – 1840 (0 – 868)	14 (356)	12 1/2 (318)	9 7/8 (251) Round
12	0 – 2500 (0 – 1180)	16 (406)	15 (381)	11 7/8 (302) Round
14	0 – 3370 (0 – 1590)	20 (508)	17 1/2 (445)	13 7/8 (352) Round
16	0 – 4525 (0 – 2135)	24 (610)	18 (457)	15 7/8 (403) Round
24 x 16	0 – 8330 (0 – 3931)	38 (965)	18 (457)	23 7/8 x 15 7/8 (606 x 403) Rect.

* Maximum airflow limit is based upon 1.5" w.g. (373 Pa) max. differential pressure signal from Flow Sensor.

Standard Features:

- Bottom mount controls location with vertical drive shaft (option code OB).
- 22 ga. (0.86) galvanized steel casing, mechanically sealed, low leakage construction. Leakage is less than 1% of the terminal rated airflow at 1" w.g. (250 Pa).
- 2 x 20 ga. (0.86) round laminated butterfly damper with a polyurethane peripheral gasket. 90° rotation, CW to close. Tight shut-off. Damper leakage is less the 1% of the terminal rated airflow at 3" w.g. (750 pa.) and less than 2% at 6" w.g. (1500 pa.) as tested in accordance with ANSI / ASHRAE Standard 130.
- 1/2" (13) dia. plated steel drive shaft. An indicator mark on the end of the shaft shows damper position.
- Unit sizes 4–16 feature round inlet collars.

- Multi-point averaging Diamond Flow Sensor. Supplied with balancing tees (4 and 5 are Annubar).
 - Rectangular discharge with slip and drive cleat duct connection.
 - Full NEMA 1 type controls enclosure for factory mounted controls.
 - 3/4" (19), dual density insulation, exposed edges coated to prevent air erosion. Meets the requirements of NFPA 90A and UL 181.
- Digital Controls:**
- Factory mounted (supplied by others)
 - Field mounted (supplied by others)
 - Nailor EZvav
- See separate submittal.



Options and Accessories:

- 24 VAC control transformer
 - Toggle disconnect switch
 - Dust tight enclosure seal
- Liner:**
- Steri-liner
 - Steri-liner + Perforated metal
 - Fiber-free
 - Perforated metal
 - Solid metal
 - 1" (25) fiberglass
- Flow Sensor:**
- Diamond Flow Sensor, removable
 - Cross Flow Sensor
 - Cross Flow Sensor, removable
- Other:**
- Side access door
 - Hanger brackets
 - Ultra low leakage casing
 - Controls enclosure for field mounted controls
 - Special features: _____

SCHEDULE TYPE
PROJECT
ENGINEER
CONTRACTOR

Page 1 of 2. Dimensions are in inches (mm).			
DATE	B SERIES	SUPERSEDES	DRAWING NO.
1 - 10 - 25	3100	2 - 6 - 23	D3101-2

AT3I 3' Integral Sound Attenuator

- Single continuous length terminal construction minimizes casing leakage.
- Continuous internal insulation reduces insulation seams and minimizes airflow disturbance.
- Supplied with same liner as basic unit.

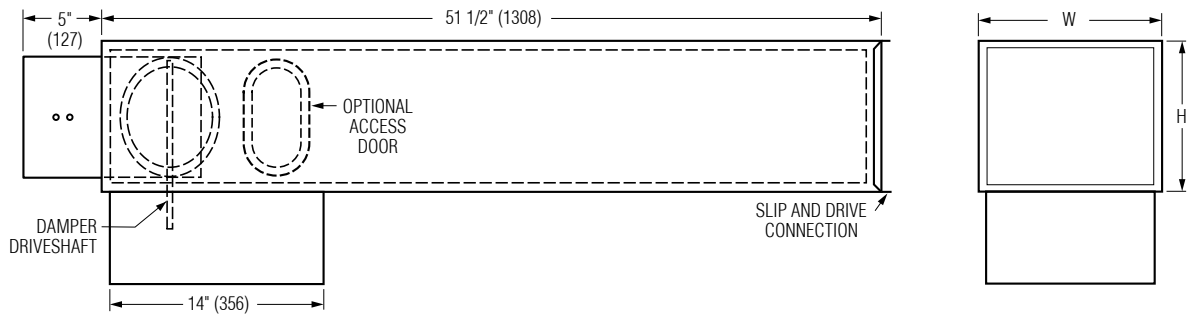

AT3S 3' Separate Discharge Sound Attenuator

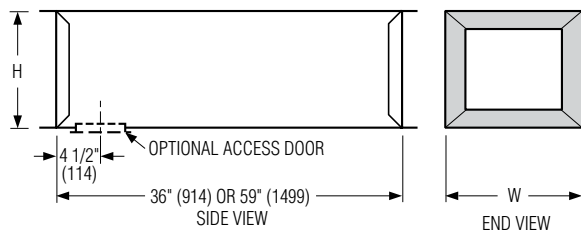

- 22 ga. (0.86) galvanized steel construction.
 - Slip and drive connection.
 - Supplied with same liner as basic unit.
- Standalone Models:**
- AT303 3' (916) Long - Standard.**
 - AT305 5' (1524) Long - Optional.**
 - Special Features:**

FF Round Discharge Collar

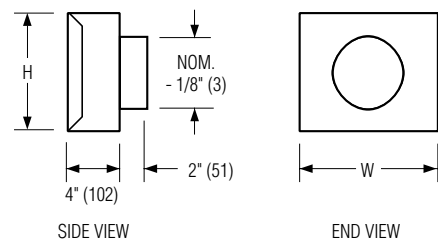

FTL Low Temperature Construction

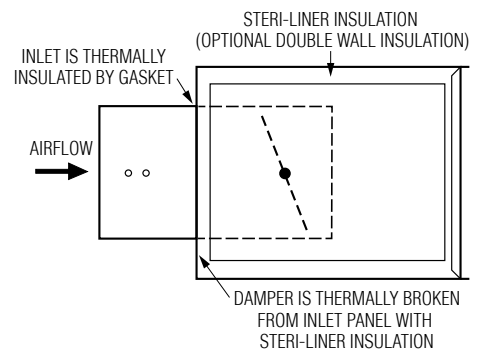

Dimensional Data

Unit Size	W	H	Access Door	FF Nominal Outlet Size
4, 5, 6	12 (305)	8 (203)	8 x 5 (203 x 127) Flat Oval	4, 5, 6 (102, 127, 152)
7, 8	12 (305)	10 (254)		7, 8 (178, 203)
9, 10	14 (356)	12 1/2 (318)		9, 10 (229, 254)
12	16 (406)	15 (381)		12 (305)
14	20 (508)	17 1/2 (445)	12 x 6 (305 x 152) Flat Oval	14 (356)
16	24 (610)	18 (457)		16 (406)
24 x 16	38 (965)	18 (457)		-

SCHEDULE TYPE

PROJECT

ENGINEER

CONTRACTOR

Page 2 of 2.
Dimensions are in inches (mm).

DATE

B SERIES

SUPERSEDES

DRAWING NO.

1 - 10 - 25

3100

2 - 6 - 23

D3101-2