

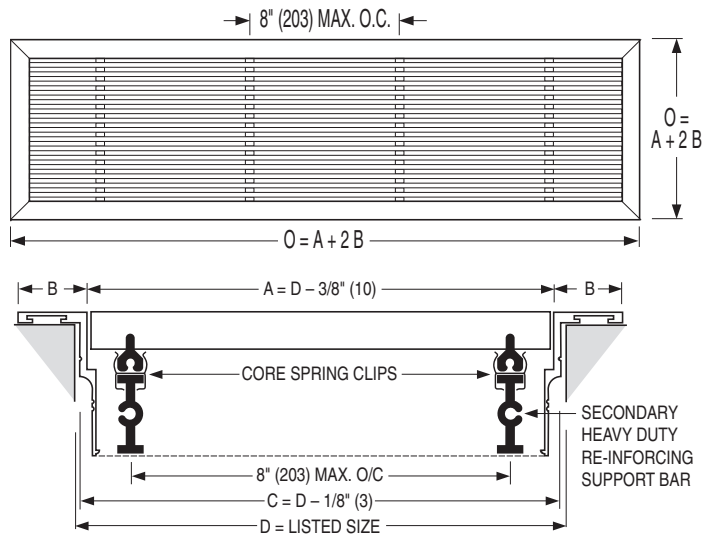

DISPLACEMENT LINEAR FLOOR DIFFUSER
 1-WAY OR 2-WAY DISCHARGE
 ALUMINUM • REMOVABLE CORE
 MODEL: DLFD



Dimensional Data:

Model DLFD (L x W):		
Minimum	Maximum	
Single Section	Single Section	Multiple Section
12 x 6 (305 x 152)	72 x 12 (1829 x 305)	Unlimited

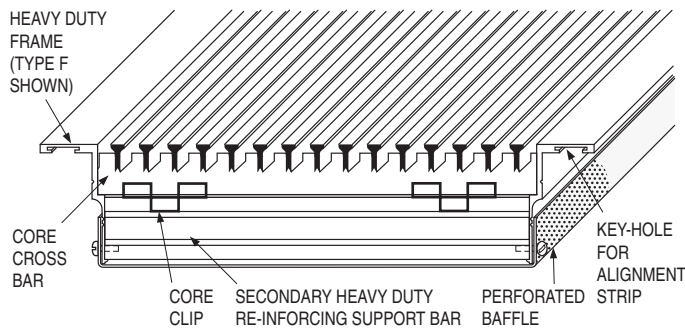

DESCRIPTION:

1. Material: Heavy duty aluminum construction.
2. Designed for raised floor installations, floor cavity or sill top.
3. Heavy duty linear bar face with integral perforated equalization baffle available in a 1-way or 2-way discharge air pattern ensures an even distribution of low velocity supply air.
4. End caps are staked, welded and mitered.
5. Heavy duty core is removable, supplied with core spring clips as standard and reinforced with additional cross-bar support.
6. Spacing does not exceed 8" (203) centers.
7. Standard finish is AW Appliance White. Optional finishes are available.

OPTION:

- DV Directional Vanes. Fully adjustable.

Core Selection:

- 480 (Standard)**
 - 1/4" (6) Spacing
 - 1/8" (3) Bars
 - 0° Deflection
- 481**
 - 1/4" (6) Spacing
 - 1/8" (3) Bars
 - 15° Deflection
- 240**
 - 1/2" (13) Spacing
 - 1/4" (6) Bars
 - 0° Deflection
- 241**
 - 1/2" (13) Spacing
 - 1/4" (6) Bars
 - 15° Deflection
- 243**
 - 1/2" (13) Spacing
 - 1/4" (6) Bars
 - 30° Deflection
- 243T**
 - 1/2" (13) Spacing
 - 1/4" (6) Bars
 - 30° Deflection
 - 2-Way Discharge

Frame Selection:

- F (Standard)**
 - 1" (25) Border Flange
- H (Optional)**
 - 3/4" (19) Beveled Border Flange

Fastening Selection:

- B (Standard)**
 - Spring Clip
 - (Frames F or H)
- A (Optional)**
 - #8 Countersunk Screw Holes
 - (Frame F only)

Dimensions are in inches (mm).

SCHEDULE TYPE:				
PROJECT:				
ENGINEER:	DATE	B SERIES	SUPERSEDES	DRAWING NO.
CONTRACTOR:	1 - 18 - 18	DLF	NEW	DLFD