



IOM

Installation and Operation Manual

Serenity Packaged Water Source Heat Pump Units Model Series 44P





CONTENTS

- 1. PREFACE4**
- 2. SAFETY SYMBOLS & CONSIDERATIONS.....4**
- 3. SAFETY PRECAUTIONS.....4**
 - 3.1 Inspections 4
 - 3.2 Storage 4
 - 3.3 Pre-Commissioning 4
 - 3.4 Safety..... 4
 - 3.5 Installation..... 4
- 4. PRE-INSTALLATION6-7**
 - 4.1 Location..... 6
 - 4.2 Sound 6
 - 4.3 Package Removal..... 6
 - 4.4 Water Quality 6
 - 4.5 Checks to the Area 7
 - 4.6 Pre-Installation Checklist..... 6-7
- 5. CLEARANCE REQUIREMENTS7**
 - 5.1 Model 44PV-B • Vertical Packaged Water Source Heat Pump Units 7
 - 5.2 Model 44PH-B • Horizontal Packaged Water Source Heat Pump Units 7
- 6. GENERAL INFORMATION.....8**
- 7. GENERAL9**
- 8. SAFETY CONSIDERATIONS.....9**
- 9. DANGER9**
- 10. REFRIGERANT SYSTEM - SERVICING9-11**
 - 10.1 Removal and Evacuation..... 9
 - 10.2 Charging Procedures..... 10
 - 10.3 Leak Detection..... 10
 - 10.4 Decommissioning..... 10-11
 - 10.5 Labeling..... 11
 - 10.6 Recovery..... 11
- 11. WARNING1-12**
- 12. CAUTION.....12**
- 13. UNPACKING AND INSPECTION..... 12-13**
- 14. SHIP LOOSE ITEMS13**
- 15. COOLING/HEATING CONNECTIONS13**
- 16. FLEX HOSE.....13**
- 17. DUCT SYSTEM INSTALLATION13**
- 18. REFRIGERANT DETECTION SYSTEM.13**
- 19. WATER QUALITY REQUIREMENTS.....14**
- 20. WATER QUALITY REQUIREMENTS.....14-15**
- 21. PIPING SYSTEM CLEANING AND FLUSHING.....16**



CONTENTS (CON'T)

22. INSTALLATION	16-17
22.1 Piping.....	16
22.2 High Voltage Wiring.....	16
22.3 Low Voltage Wiring.....	16
22.4 Wiring Connections.....	16
22.5 Condensate Drain.....	17
23. MOUNTING • MODEL 44PV-B VERTICAL PACKAGED WSHP UNITS	17
23.1 Location.....	17
24. MOUNTING • MODEL 44PH-B HORIZONTAL PACKAGED WSHP UNITS	17-18
24.1 Location.....	17
24.2 Mounting.....	18
25. AIR DISCHARGE • MODEL 44PV-B VERTICAL PACKAGED WSHP UNITS	18
25.1 Vertical Supply Air Discharge.....	18
25.2 Vertical Return Air Discharge.....	18
26. AIR DISCHARGE CONVERSION • MODEL 44PH-B HORIZONTAL PACKAGED WSHP UNITS	18-19
26.1 Horizontal Supply Air Discharge.....	18-19
26.2 Horizontal Return Air Discharge.....	19
27. DUCT INSTALLATION	19
28. WATER PIPING INSTALLATION	19
29. CONDENSATE DRAIN	19-20
30. UNIT START-UP	20-21
30.1 Pre-Start-Up Checklist.....	20
30.2 Start-Up Steps.....	20
30.3 Start-Up Form.....	20
30.4 Auxiliary Electric Heat.....	21
31. HEAT PUMP CHARGING	22
32. AIR FILTERS	22
33. DRAIN PAN	22
34. RETURN AIR FILTER	22
35. AIR COIL	22
36. FILTER SELECTION	22
37. TYPICAL PACKAGED WSHP OPERATING TEMPERATURES	23
38. CONTROL OPERATION	23-24
39. TROUBLE DIAGNOSIS	24
40. FAN MOTOR FAILS TO START	24-25
41. HEAT PUMP UNIT FAILS TO START	25
42. HEAT PUMP UNIT STARTS BUT CUTS OFF COOLING ONLY UNITS	25-26
43. HEAT PUMP UNIT STARTS BUT CUTS OFF HEATING AND COOLING	26
44. HEAT PUMP UNIT OPERATING BUT NOT HEATING (REVERSE CYCLE ONLY)	26
45. WIRING DIAGRAMS	27
46. WIRING DIAGRAM	28

1 PREFACE

Your equipment is initially protected under the manufacturer’s standard warranty. However, this warranty is provided under the condition that the steps outlined in this manual are followed for initial inspection, proper installation, periodic maintenance and everyday operation of the equipment.

This manual should be fully reviewed in advance of any actual work being done on the equipment. Should any questions arise, please contact your local Sales Representative or the factory before proceeding.

Consult the approved unit submittal, order acknowledgment, and other manuals for details on the applications and accessories provided with the equipment on each project.

Always follow proper procedures related to safety, handling, installation, operation, servicing of mechanical equipment as the manufacturer assumes no responsibility for personal injury or property damage resulting from improper or unsafe practices during handling, service or operation of any equipment.

2 SAFETY SYMBOLS & CONSIDERATIONS

The equipment covered by this manual is designed for safe and reliable operation within its design specification limits. To avoid personal injury or damage to equipment or property while installing or operating this equipment, it is essential that qualified, experienced personnel perform these functions using good judgment and safe practices. To promote safety, the following symbols are used in this document to alert the reader to potential hazards:



DANGER indicates an imminently hazardous situation which, if not avoided, will result in death or serious injury.



CAUTION identifies a hazard which could lead to damage to the machine, damage to other equipment and/or environmental pollution. Usually an instruction will be given, together with a brief explanation.



WARNING indicates a potentially hazardous situation which, if not avoided, could result in death or serious injury.



NOTICE is used to indicate an item or situation that is not hazardous, but important to system operation, installation or maintenance.



WARNING indicates a potentially hazardous situation which, if not avoided, could result in electric shock hazard. May result in injury or death!

3 SAFETY PRECAUTIONS

Please be sure to familiarize yourself with all sections of this manual before beginning installation, maintenance or service.

3.1 Inspection

Upon the unit(s) arrival it is the customer's job to ensure the units received are accounted for versus the bill of lading or purchase order. Once units are accounted inspect each unit for signs of damage. Any damage discovered should be noted by the freight carrier and a common carrier inspection report should be filed. Internal or concealed damage that was not discovered during delivery must be reported to the carrier within 15 days of its receipt of shipment. The freight company can deny the claim for reports exceeding 15 days. Please note, it is the purchaser’s responsibility to report any damages.

3.2 Storage

If units are not going to be immediately installed, they must be stored in a dry, clean area where they will not be susceptible to damage. Do not remove any packaging, pallets, or other shipping material until units are ready to be installed. Units should be stored in an upright position, and stacked to a maximum of 2 units high.

3.3 Pre-Commissioning

If units are going to be installed, but not immediately commissioned, care must be taken to protect the units from dust contamination and other building debris.

3.4 Safety

When installing, servicing, or performing maintenance on any unit, make sure protective clothing, gloves, and safety goggles are worn.

3.5 Installation

Equipment's maximum altitude of use is 2,200 m. The equipment shall be installed in accordance with national wiring regulations.



Disconnect power supply(ies) before servicing. Refer servicing to qualified service personnel. Electric shock hazard. May result in injury or death!



To avoid the release of refrigerant into the atmosphere, the refrigerant circuit of this unit must be serviced only by technicians who meet local, state, and federal proficiency requirements.



The installation of water-source heat pumps and all associated components, parts, and accessories which make up the installation shall be in accordance with the regulations of ALL authorities having jurisdiction and MUST conform to all applicable codes. It is the responsibility of the installing contractor to determine and comply with ALL applicable codes and regulations.



The appliance shall be stored in a room without continuously operating ignition sources (for example: open flames, an operating gas appliance or an operating electric heater).



If a unit is connected via an air duct system to one or more rooms with R-454B and is installed in a room with an area less than Amin or has an Effective Dispersal Volume less than minimum, that room shall be without continuously operating open flames or other POTENTIAL IGNITION SOURCES. A flame-producing device may be installed in the same space if the device is provided with an effective flame arrest.



All refrigerant discharged from this unit must be recovered WITHOUT EXCEPTION. Technicians must follow industry accepted guidelines and all local, state, and federal statutes for the recovery and disposal of refrigerants. If a compressor is removed from this unit, refrigerant circuit oil will remain in the compressor. To avoid leakage of compressor oil, refrigerant lines of the compressor must be sealed after it is removed.



This appliance is not intended for use by persons (including children) with reduced physical, sensory, or mental capabilities, or lack of experience and knowledge, unless they have been given supervision or instruction concerning use of the appliance by a person responsible for their safety.



An unventilated area where the appliance using FLAMMABLE REFRIGERANTS is installed shall be so constructed that should any refrigerant leak, it will not stagnate so as to create a fire or explosion hazard.



Auxiliary devices which may be a POTENTIAL IGNITION SOURCE shall not be installed in the duct work. Examples of such POTENTIAL IGNITION SOURCES are hot surfaces with a temperature exceeding 1,292°F (700°C).



An unventilated area where a water source heat pump is installed and surpasses a R-454B refrigerant charge of 62 oz (1.76 kg), shall be without continuously operating open flames (for example an operating gas appliance) or other POTENTIAL IGNITION SOURCES (for example, an operating electric heater, hot surfaces).



For mechanical ventilation, the lower edge of the air extraction opening where air is exhausted from the room Vertically Center to Warning Symbol shall not be more than 3.94 inches (100 mm) above the floor. The location where the mechanical ventilation air extracted from the space is discharged shall be separated by a sufficient distance, but not less than 9.84 feet (3 m), from mechanical ventilation air intake openings, to prevent recirculation to the space.



Children being supervised are NOT to play with the appliance. Do not pierce or burn. Be aware that refrigerants may not contain odor.



DO NOT store or install units in corrosive environments or in locations subject to temperature or humidity extremes (e.g., attics, garages, rooftops, etc.). Corrosive conditions and high temperature or humidity can significantly reduce performance, reliability, and service life. Always move and store units in an upright position. Tilting units on their sides will cause equipment damage.



CUT HAZARD - Failure to follow this caution may result in personal injury. Sheet metal parts may have sharp edges or burrs. Use care and wear appropriate protective clothing, safety glasses and gloves when handling parts and servicing heat pumps.



To avoid equipment damage, DO NOT use these units as a source of heating or cooling during the construction process. The mechanical components and filters can quickly become clogged with construction dirt and debris, which may cause system damage and void product warranty.



All three phase scroll compressors must have direction of rotation verified at startup. Verification is achieved by checking compressor Amp draw. Amp draw will be substantially lower compared to nameplate values. Additionally, reverse rotation results in an elevated sound level compared to correct rotation. Reverse rotation will result in compressor internal overload trip within several minutes. Verify compressor type before proceeding.



Servicing shall be performed only as recommended by the manufacturer.

REFRIGERANT SENSORS for REFRIGERANT DETECTION SYSTEMS shall only be replaced with sensors specified by the appliance manufacturer.

An unconditioned attic is not considered natural ventilation.

This unit is equipped with electrically powered safety measures. To be effective, the unit must be electrically powered at all times after installation, other than when servicing.

For Installation Only in Locations Not Accessible to the General Public.

LEAK DETECTION SYSTEM installed. Unit must be powered except for service.



Maximum water temperature: 120 °F; Minimum water temperature: 20 °F

Maximum water pressure: 400 psig; Minimum water pressure: 5 psig

4 PRE-INSTALLATION

4.1 Location

The area where the units are to be installed should be selected carefully. Installation area should provide adequate service access, and access to utilities and ductwork. Units are designed for in wall installation and mechanical rooms. The installation site should have adequate clearance around the unit.

4.2 Sound

All units should utilize flex connectors in the supply and return ductwork. Vertical units should be placed on a foam or plastic vibration isolation pad.

4.3 Packaging Removal

Remove all packaging and wrapping from the unit prior to installation. Check inside the unit for additional supports, or other shipping protection materials. All packaging materials should be properly disposed of.

4.4 Water Quality

The condenser water system must be clean and contain minimum oxygen levels to prevent corrosion. Condenser water pH, total dissolved solids and total suspended solids must be maintained within proper limits to prevent equipment failure.

Total dissolved solids should not exceed 1000 ppm for a glycol system and 300 ppm for a water-only system. Total suspended solids should not exceed 75 ppm. PH should be between 6.8 and 8.4. Corrosive fluids can degrade unit heat exchangers, cause leaks potentially damaging the unit, and the space it is installed in.



Units should never be used as a source of space heating or cooling while building construction is in-progress. Equipment damage from clogged air filters/air coils can occur, and will not be covered under warranty.

4.5 Checks to the Area

Prior to beginning work on systems containing FLAMMABLE REFRIGERANTS, safety checks are necessary to ensure that the risk of ignition is minimized. For repair to the REFRIGERATING SYSTEM, these steps shall be completed prior to conducting work on the system.

4.6 Pre-Installation Checklist

- Confirm the unit data plate for the model number or tag number with ordering information and shipping information to verify the correct unit is being installed.
- Inspect the exterior of the unit for any damage, or other items which would hinder installation.
- The cabinet should be covered and protected with original packaging until units are ready for installation.
- Check the unit data for electrical data, and then verify the supplied service is correct.
- Remove internal supplement packaging such as blower supports, compressor shipping brackets, manuals, etc.
- Remove air filter(s) and check for any visible damage to the air coil. (If applicable)

- Verify internally that refrigerant/ water tubing is free of dents or kinks and is not in contact with other materials.
- Ensure all high and low voltage electrical connections are clean tightly secured.



Units, accessories, and all relevant components and parts must be installed in accordance with any and all local regulations. The installer is responsible for determining what codes and standards apply for their particular application

5. CLEARANCE REQUIREMENTS

1. Front of unit is located by the unit control box. 36" (914) clearance is required by the National Electric Code.
2. While clear access to all removable panels is not required, installer should take care to comply with all building codes and allow adequate clearance for future field service.
3. Front or side access is preferred for service access depending on unit options.

5.1 Model 44PV-B • Vertical Packaged Water Source Heat Pump Units

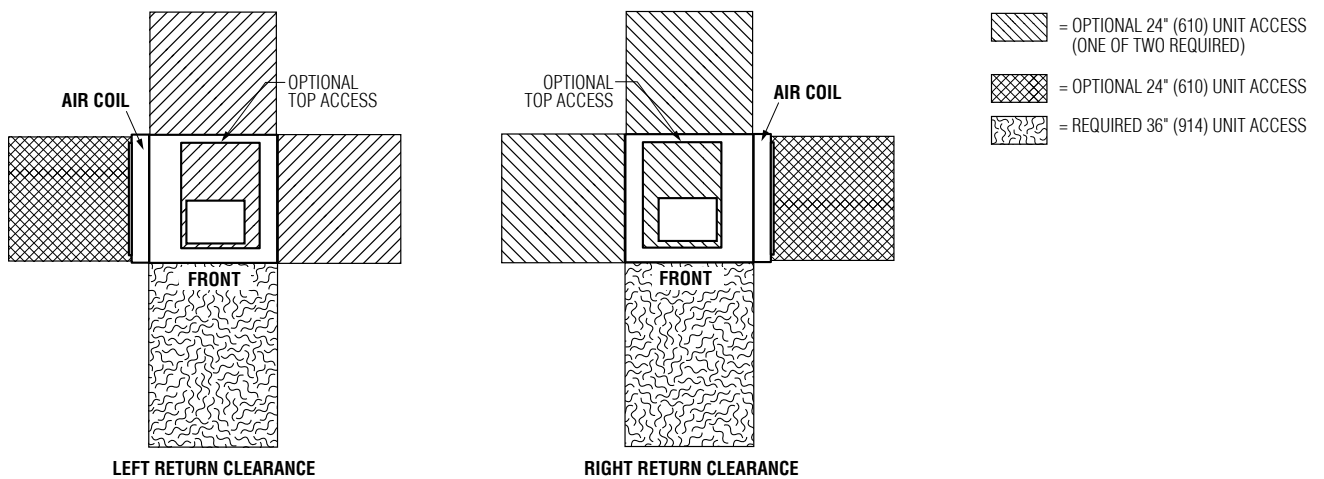

5.2 Model 44PH-B • Horizontal Packaged Water Source Heat Pump Units

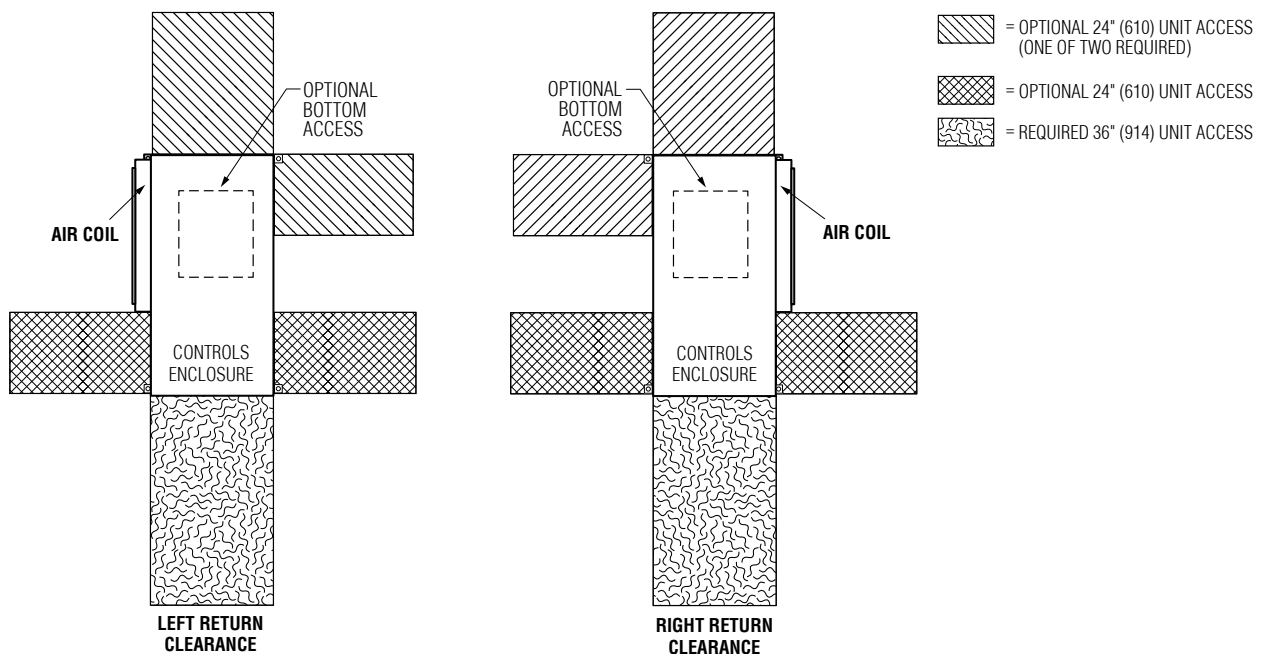

6 GENERAL INFORMATION

6.1 Work Procedure

Work shall be undertaken under a controlled procedure so as to minimize the risk of a flammable gas or vapor being present while the work is being performed.

6.2 General Work Area

All maintenance staff and others working in the local area shall be instructed on the nature of work being carried out. Work in confined spaces shall be avoided.

6.3 Checking for presence of refrigerant

The area shall be checked with an appropriate refrigerant detector prior to and during work, to ensure the technician is aware of potentially toxic or flammable atmospheres. Ensure that the leak detection equipment being used is suitable for use with all applicable refrigerants, i.e. non-sparking, adequately sealed or intrinsically safe.

6.4 Presence of fire Extinguisher

If any hot work is to be conducted on the refrigeration equipment or any associated parts, appropriate fire extinguishing equipment shall be available. Have a dry powder or CO₂ fire extinguisher adjacent to the charging area.

6.5 No ignition sources.

No person carrying out work in relation to a REFRIGERATION SYSTEM which involves exposing any pipe work shall use any sources of ignition in such a manner that it may lead to the risk of fire or explosion. All possible ignition sources, including cigarette smoking, should be kept sufficiently far away from the site of installation, repairing, removing and disposal, during which refrigerant can possibly be released to the surrounding space. Prior to work taking place, the area around the equipment is to be surveyed to make sure that there are no flammable hazards or ignition risks. "No Smoking" signs shall be displayed.

6.6 Ventilated area

Ensure that the area is in the open or that it is adequately ventilated before breaking into the system or conducting any hot work. A degree of ventilation shall continue during the period that the work is carried out. The ventilation should safely disperse any released refrigerant and preferably expel it externally into the atmosphere.

6.7 Checks to the Refrigeration Equipment

The following checks shall be applied to installations using FLAMMABLE REFRIGERANTS:

- The actual REFRIGERANT CHARGE is in accordance with the room size within which the refrigerant containing parts are installed.
- The ventilation machinery and outlets are operating adequately and are not obstructed;
- If an indirect refrigerating circuit is being used, the secondary circuit shall be checked for the presence of refrigerant.
- Marking to the equipment continues to be visible and legible. Markings and signs that are illegible shall be corrected.
- Refrigerant piping or components are installed in a position where they are unlikely to be exposed to any substance which may corrode refrigerant containing components, unless the components are constructed of materials which are inherently resistant to being corroded or are suitably protected against being so corroded.

6.8. Checks to Electrical Devices

Repair and maintenance to electrical components shall include initial safety checks and component inspection procedures. If a fault exists that could compromise safety, then no electrical supply shall be connected to the circuit until it is satisfactorily dealt with. If the fault cannot be corrected immediately but it is necessary to continue operation, an adequate temporary solution shall be used. This shall be reported to the owner of the equipment, so all parties are advised.

6.9 Initial safety checks shall include:

- Capacitors are discharged: this shall be done in a safe manner to avoid possibility of sparking.
- That no live electrical components and wiring are exposed while charging, recovering, or purging the system.
- That there is continuity of earth bonding.

6.10 Repair to intrinsically safe components

Intrinsically safe components must be replaced.

6.11 Cabling

Check that cabling will not be subject to wear, corrosion, excessive pressure, vibration, sharp edges or any other adverse environmental effects. The check shall also take into account the effects of aging or continual vibration from sources such as compressors or fans.



Installation and Operation Manual • Serenity Packaged Water Source Heat Pump Units – Model Series 44P

6.12 Required area for installation

The minimum room area of the space (Amin) or a minimum room area of conditioned space (Tamin) shall be corrected for unit's location altitude by multiplying Amin or Tamin by the applicable altitude adjustment factor (AF) for building ground-level altitude (Halt) in feet or meters, as shown in Table 1.

Halt ft (m)	0 (0)	656 (200)	1,312 (400)	1,968 (600)	2,624 (800)	3,280 (1,000)	3,937 (1,200)	4,593 (1,400)	5,249 (1,600)	5,905 (1,800)	6,561 (2,000)	7,217 (2,200)	7,874 (2,400)	8,530 (2,600)	9,186 (2,800)	9,842 (3,000)	10,498 (3,200)
AF	1	1	1	1	1.02	1.05	1.07	1.1	1.12	1.15	1.18	1.21	1.25	1.28	1.32	1.36	1.4

NOTE: YOU CAN USE IMPERIAL OR METRIC MEASUREMENTS TO CALCULATE

7 GENERAL

Engineered Comfort Industries Water Source Heat Pumps represent an investment, which can, when installed and operated properly, give long and trouble free service.

Your equipment is initially protected under the manufacturer's standard warranty. However, this warranty is provided under the condition that the steps outlined in this manual for initial inspection, proper installation, periodic maintenance and everyday operation of the equipment be followed in detail. This manual should be fully reviewed in advance of any actual work being done on the equipment. Should any questions arise, please contact your local Sales Representative or the factory BEFORE proceeding.

Engineered Comfort's Water Source Heat Pumps use R-454B as the refrigerant. Only qualified personnel should install and service this unit.

8. SAFETY CONSIDERATIONS

The equipment covered by this manual is designed for safe and reliable operation within its design specification limits. To avoid personal injury or damage to equipment or property while installing or operating this equipment, it is essential that qualified, experienced personnel perform these functions using good judgment and safe practices. See the following cautionary statements.

9. DANGER

ELECTRICAL SHOCK HAZARDS. All power must be disconnected prior to installation and servicing this equipment. There may be more than one power source present. Insure that all power sources have been disconnected to avoid electrocution or shock injuries.

MOVING PARTS HAZARD. Motor and blower must be disconnected prior to opening access panels. Motors can start automatically; disconnect all power and control circuits prior to servicing to avoid serious crushing or dismemberment injuries.

10 REFRIGERANT SYSTEM - SERVICING

To maintain sealed circuit integrity, do not install service gauges unless unit operation appears abnormal. Reference the operating charts for pressures and temperatures. Verify that air and water flow rates are at proper levels before servicing the refrigerant circuit.

10.1 Removal and Evacuation

When breaking into the refrigerant circuit to make repairs - or for any other purpose - conventional procedures shall be used. However, for flammable refrigerants it is important that best practice be followed, since flammability is a consideration. The following procedure shall be adhered to:

- Safely remove refrigerant following local and national regulations
- Evacuate
- Purge the circuit with Inert gas
- Evacuate
- Continuously flush or purge with Inert gas when using flame to open circuit
- Open the circuit.

The refrigerant charge shall be recovered into the correct recovery cylinders if venting is not allowed by local and national codes. For appliances containing flammable refrigerants, the system shall be purged with oxygen-free nitrogen to render the appliance safe. This process might need to be repeated several times. Compressed air or oxygen shall not be used for purging refrigerant systems.

For appliances containing flammable refrigerants, refrigerant purging shall be achieved by breaking the vacuum in the system with oxygen-free nitrogen and continuing to fill until the working pressure is achieved, then venting to

atmosphere, and finally pulling down to a vacuum (optional for FLAMMABLE REFRIGERANT). This process shall be repeated until no refrigerant remains in the system (optional for FLAMMABLE REFRIGERANT). When the final oxygen-free nitrogen charge is used, the system shall be vented down to atmospheric pressure to enable work to take place.

The outlet for the vacuum pump shall not be close to any potential ignition sources, and ventilation shall be available.

10.2 Charging Procedures

In addition to conventional charging procedures, the following requirements shall be followed:

- Ensure that contamination of different refrigerants does not occur when using charging equipment.
- Hoses or lines shall be as short as possible to minimize the amount of refrigerant contained in them.
- Cylinders shall be kept in an appropriate position according to the instructions.

Ensure that the REFRIGERATION SYSTEM is earthed prior to charging the system with refrigerant.

Label the system when charging is complete (if not already).

Extreme care shall be taken not to overfill the REFRIGERATION SYSTEM.

Prior to recharging the system, it shall be pressure- tested with the appropriate purging gas. The system shall be leak-tested on completion of charging but prior to commissioning. A follow up leak test shall be carried out prior to leaving the site.

10.3 Leak Detection

Under no circumstances shall potential sources of ignition be used in the searching for or detection of refrigerant leaks. A halide torch (or any other detector using a naked flame) shall not be used.

The following leak detection methods are deemed acceptable for all refrigerant systems.

Electronic leak detectors may be used to detect refrigerant leaks but, in the case of FLAMMABLE REFRIGERANTS, the sensitivity may not be adequate, or may need re-calibration. (Detection equipment shall be calibrated in a refrigerant-free area.)

Ensure that the detector is not a potential source of ignition and is suitable for the refrigerant used. Leak detection equipment shall be set at a percentage of the lower flammability limit of the refrigerant and shall be calibrated to the refrigerant employed, and the appropriate percentage of gas (25% maximum) is confirmed.

Leak detection fluids are also suitable for use with most refrigerants but the use of detergents containing chlorine shall be avoided as the chlorine may react with the refrigerant and corrode the copper pipe-work.

NOTE: Examples of leak detection fluids are:

- Bubble method
- Fluorescent method agents

If a leak is suspected, all naked flames shall be removed/extinguished.

If a refrigerant leak that requires brazing is identified, all of the refrigerant shall be recovered from the system, or isolated (by means of shut off valves) in a part of the system remote from the leak. Removal of refrigerant shall be according to Removal and Evacuation section.

10.4 Decommissioning

Before carrying out this procedure, it is essential that the technician is completely familiar with the equipment and all its detail. It is recommended good practice that all refrigerants are recovered safely. Prior to the task being carried out, an oil and refrigerant sample shall be taken in case analysis is required prior to re-use of recovered refrigerant. It is essential that electrical power is available before the task is commenced.

4. Become familiar with the equipment and its operation.
5. Isolate system electrically.
6. Before attempting the procedure, ensure that:
 - Mechanical handling equipment is available, if required, for handling refrigerant cylinders.
 - All personal protective equipment is available and being used correctly.
 - The recovery process is supervised at all times by a competent person.
 - Recovery equipment and cylinders conform to the appropriate standards.
7. Pump down refrigerant system, if possible.
8. If a vacuum is not possible, make a manifold so that refrigerant can be removed from various parts of the system.

9. Make sure that cylinder is situated on the scales before recovery takes place.
10. Start the recovery machine and operate in accordance with instructions.
11. Do not overfill cylinders (no more than 80 % volume liquid charge).
12. Do not exceed the maximum working pressure of the cylinder, even temporarily.
13. When the cylinders have been filled correctly and the process completed, make sure that the cylinders and the equipment are removed from site promptly and all isolation valves on the equipment are closed off.
14. Recovered refrigerant shall not be charged into another REFRIGERATING SYSTEM unless it has been cleaned and checked.

10.5 Labeling

Upon decommissioning, equipment shall be labeled stating that it has been decommissioned and emptied of refrigerant. The label shall be dated and signed.

10.6 Recovery

When removing refrigerant from a system, either for servicing or decommissioning, it is recommended good practice that all refrigerants are removed safely.

When transferring refrigerant into cylinders, ensure that only appropriate refrigerant recovery cylinders are employed. Ensure that the correct number of cylinders for holding the total system charge is available. All cylinders to be used are designated for the recovered refrigerant and labeled for that refrigerant (i.e. special cylinders for the recovery of refrigerant). Cylinders shall be complete with pressure-relief valve and associated shut-off valves in good working order. Empty recovery cylinders are evacuated and, if possible, cooled before recovery occurs.

The recovery equipment shall be in good working order with a set of instructions concerning the equipment that is at hand and shall be suitable for the recovery of the flammable refrigerant. If in doubt, the manufacturer should be consulted.

In addition, a set of calibrated weighing scales shall be available and in good working order. Hoses shall be complete with leak-free disconnect couplings and in good condition.

The recovered refrigerant shall be processed according to local legislation in the correct recovery cylinder, and the relevant waste transfer note arranged. Do not mix refrigerants in recovery units and especially not in cylinders.

If compressors or compressor oils are to be removed, ensure that they have been evacuated to an acceptable level to make certain that flammable refrigerant does not remain within the lubricant. The compressor body shall not be heated by an open flame or other ignition sources to accelerate this process. When oil is drained from a system, it shall be carried out safely.

11. WARNING



Verify refrigerant type before proceeding. Units are shipped with R-454B refrigerants. The nameplate label will indicate which refrigerant is provided.

To avoid the release of refrigerant into the atmosphere, the refrigerant circuit of this unit must be serviced only by technicians who meet local, state, and federal proficiency requirements.

The installation of water-source heat pumps and all associated components, parts, and accessories which make up the installation shall be in accordance with the regulations of ALL authorities having jurisdiction and **MUST** conform to all applicable codes. It is the responsibility of the installing contractor to determine and comply with ALL applicable codes and regulations.

All refrigerant discharged from this unit must be recovered **WITHOUT EXCEPTION**. Technicians must follow industry accepted guidelines and all local, state, and federal statutes for the recovery and disposal of refrigerants. If a compressor is removed from this unit, refrigerant circuit oil will remain in the compressor. To avoid leakage of compressor oil, refrigerant lines of the compressor must be sealed after it is removed.

To avoid equipment damage, **DO NOT** use these units as a source of heating or cooling during the construction process. The mechanical components and filters will quickly become clogged with construction dirt and debris, which may cause system damage.

Polyolester Oil, commonly known as POE oil, is a synthetic oil used in many refrigeration systems including those with R-454B refrigerant. POE oil, if it ever comes in contact with PVC or CPVC piping, may cause failure of the PVC/CPVC. PVC/CPVC piping should never be used as supply or return water piping with water source heat pump products containing R-454B as system failures and property damage may result.

Installation and Operation Manual • Serenity Packaged Water Source Heat Pump Units – Model Series 44P

Ensure that rigging and lifting equipment are of sufficient capacity to support the weight of the unit.

All assemblies must be secured during lifting and rigging with temporary supports and restraints of adequate size and strength according to local codes and ordinances until the equipment is permanently fixed in place.

All fastening devices must be capable of locking the assembly in place without loosening or breaking away due to system operation and vibration.

Engineered Comfort tests all risers and coil packages to 400PSI for leaks before shipping. However, during transit, vibration may cause loosening of connections. Therefore, all connections must be checked at time of installation.

Any connection found to be loose must be tightened. Engineered Comfort will not be held responsible or accept any charges for tightening loose fittings. Backup wrenches must be used during the tightening process.

Should a hose swivel connection be disconnected after it has been tightened the gasket must be checked to see if it needs replacement and replaced, if necessary, before the hose is re-attached.

Female swivel fittings with gasket should not be tightened to more than 30 in-lb of torque.

Unit must be pressure tested before applying water.

Backup wrenches must be used during any tightening process to keep the copper tube or fitting from being damaged.

Engineered Comfort will not accept any responsibility for improper tightening procedures that damage the connections.

12. CAUTION



Secure all dampers when servicing damper, actuator or linkages. Dampers may activate automatically; disconnect control circuits to avoid injury.

Protect adjacent flammable materials **WHEN** brazing. Use flame and heat protection barriers where needed. Have a fire extinguisher available and ready for immediate use.

The equipment covered by this manual is available with a variety of options and accessories. Consult the approved unit submittal, order acknowledgment and other manuals for details on the options and accessories provided with the equipment on each project.

Safe practices regarding mechanical equipment must be followed at all times when handling, installing or servicing any unit.

All power must be disconnected before any installation or service should be attempted. More than one power source may be supplied to the unit. Power to remote mounted control devices may not be supplied through the unit.

Never wear bulky or loose fitting clothing when working with mechanical equipment. Gloves should only be worn when required for proper protection from heat or other possible injury. Safety glasses or goggles should always be worn when drilling, cutting or working with chemicals such as lubricants.

Never pressurize any equipment beyond specified test pressures.

The manufacturer assumes no responsibility for personal injury or property damage resulting from improper or unsafe practices during handling service or operation of any equipment.

Corrosive system water requires corrosion resistant fittings and hoses, and may require water treatment.

Do not bend or kink supply lines or hoses.

Piping must comply with all applicable codes.

13. UNPACKING AND INSPECTION

All units have been carefully inspected, tested and packaged at Engineered Comfort's manufacturing facility.

It is the responsibility of the receiving party to inspect the equipment upon arrival. Any obvious damage to the packaging and/or its contents should be recorded on the bill of lading and a claim should be filed with the freight carrier.

After determining the condition of the unit's exterior, including all piping, each unit should be carefully removed from the package and inspected for hidden damage. Any hidden damage should be recorded and immediately reported to the carrier and a claim filed as before. Should a claim for shipping damage be filed, the unit, the shipping package and all packing must be retained for inspection by the freight carrier. All equipment should be stored in the factory shipping package until installation.

At the time of receipt, the equipment type and arrangement should be verified against the order documents. Should any discrepancy be found the local sales rep should be notified immediately so that the proper action may be instituted. The factory must be notified about any questions concerning warranty repairs **BEFORE** any corrective action is taken. Should equipment require factory operations a Return Authorization Number will be issued. Any returns not marked with an authorization number will be refused. The manufacturer will not accept claims for expenses not authorized.

14. SHIP LOOSE ITEMS

Several items are shipped loose for field installation. These items are shipped loose to offer protection against shipping and job site damage or by customer request. Refer to packing slip. These items require the same inspection as the unit.

15. COOLING/HEATING CONNECTIONS



Toxic residues and loose particles resulting from manufacturing and field piping techniques may be present in the unit and piping system.

Special consideration must be given to system cleanliness if unit is to be connected to solar, domestic or potable water systems. Submittals and Product Catalogs detailing unit operation, controls and connections should be thoroughly reviewed **BEFORE** beginning the connection of the various cooling and/or heating mediums to the unit.

All accessory valve packages should be installed as required, and all service valves should be checked for proper operation.

In cases where control valves are field installed care should be taken to ensure the valve body is not overheated when braze connections are made.

All pipe screw connections must be made using a "backup wrench" to ensure the copper tube is not twisted during the tightening sequence. If unions are used, over tightening should be avoided to prevent distortion to the union seal surfaces and destroying the union.

16. FLEX HOSE



Flex hoses should be insulated if entering water temperature in cooling mode is anticipated to be below 50 °F to prevent condensation.

17. DUCT SYSTEM INSTALLATION

An unventilated area where water source heat pump is installed and surpasses a R-454B refrigerant charge of 62 oz (1.76 kg), shall be without continuously operating open flames (for example an operating gas appliance) or other **POTENTIAL IGNITION SOURCES** (for example an operating electric heater, hot surfaces).



Ducts connected to an appliance shall not contain a POTENTIAL IGNITION SOURCE.

Keep any required ventilation openings clear of obstruction.

For mechanical ventilation, the lower edge of the air extraction opening where air is exhausted from the room shall not be more than 3.94 inches (100 mm) above the floor. The location where the mechanical ventilation air extracted from the space is discharged shall be separated by a sufficient distance, but not less than 9.84 feet (3 m), from mechanical ventilation air intake openings, to prevent recirculation to the space.

18. REFRIGERANT DETECTION SYSTEM

The function, operation, and required servicing measures for the Refrigerant Detection System include the following:

- The Refrigerant Detection System monitors the status of the refrigerant sensor(s) in the unit. If refrigerant is detected above the maximum threshold, the control enables the unit blower, disables the compressor(s), and enables the pilot relay on the Refrigerant Detection System control board. You can use this relay to open external zoning dampers and/or activate external mechanical ventilation.
- A fault is enabled if the Refrigerant Detection System control board loses communication with a refrigerant sensor or if the main control board loses communication with the Refrigerant Detection System board.



The following instructions represent industry accepted installation practices for closed loop earth coupled heat pump systems. Instructions are provided to assist the contractor in installing trouble free ground loops. These instructions are recommendations only. State/provincial and local codes MUST be followed, and installation MUST conform to ALL applicable codes. It is the responsibility of the installing contractor to determine and comply with ALL applicable codes and regulations.

19. WATER QUALITY REQUIREMENTS

Clean water is essential to the performance and life span of water source heat pumps. Contaminants, chemicals, and minerals all have the potential to cause damage to the water heat exchanger if not treated properly. All closed water loop systems should undergo water quality testing and be maintained to the water quality standards listed in this table.

	Description	Symbol	Units	Heat Exchanger Type			
				Closed Loop Recirculating		Open Loop, Tower, Ground Source Well	
				All Heat Exchanger Types	Coaxial HX Copper Tube in Tube	Coaxial HX Cupronickel	Brazed- Plate HX 316 SS
Scaling Potential	pH - Chilled Water <85°F			7.0 to 9.0	7.0 to 9.0	7.0 to 9.0	7.0 to 9.0
	pH - Chilled Water >85°F			8.0 to 10.0	8.0 to 10.0	8.0 to 10.0	8.0 to 10.0
	Alkalinity	(HCO ₃ ⁻)	ppm - CaCO ₃ equivalent	50 to 500	50 to 500	50 to 500	50 to 500
	Calcium	(Ca)	ppm	<100	<100	<100	<100
	Magnesium	(Mg)	ppm	<100	<100	<100	<100
	Total Hardness	(CaCO ₃)	ppm - CaCO ₃ equivalent	30 to 150	150 to 450	150 to 450	150 to 450
	Langelier Saturation Index	LSI		-0.5 to +0.5	-0.5 to +0.5	-0.5 to +0.5	-0.5 to +0.5
Ryznar Stability Index	RSI		6.5 to 8.0	6.5 to 8.0	6.5 to 8.0	6.5 to 8.0	
Corrosion Prevention	Total Dissolved Solids	(TDS)	ppm - CaCO ₃ equivalent	<1000	<1000	<1000	<1000
	Sulfate	(SO ₄ ²⁻)	ppm	<200	<200	<200	<200
	Nitrate	(NO ₃ ⁻)	ppm	<100	<100	<100	<100
	Chlorine (free)	(Cl)	ppm	<0.5	<0.5	<0.5	<0.5
	Chloride (water < 80°F)	(Cl ⁻)	ppm	<20	<20	<150	<150
	Chloride (water > 120°F)	(Cl ⁻)	ppm	<20	<20	<125	<125
	Hydrogen Sulfide	(H ₂ S)	ppb	<0.5	<0.5	<0.5	<0.5
	Carbon Dioxide	(CO ₂)	ppm	0	<50	10 to 50	10 to 50
	Iron Oxide	(Fe)	ppm	<1.0	<1.0	<1.0	<0.2
	Manganese	(Mn)	ppm	<0.4	<0.4	<0.4	<0.4
	Ammonia	(NH ₃)	ppm	<0.05	<0.1	<0.1	<0.1
	Chloramine	(NH ₂ CL)	ppm	0	0	0	0
Fouling & Biological	Iron bacteria		cells/mL	0	0	0	0
	Slime-forming bacteria		cells/mL	0	0	0	0
	Sulfate-reducing bacteria		cells/mL	0	0	0	0
	Suspended Solids	(TSS)	ppm	<10	<10	<10	<10
Electrolysis All HX types	Earth Ground Resistance		Ohms		Consult NEC and local electrical codes for grounding requirements		
	Electrolysis Voltage		mV		Measure voltage and internal water loop to HP ground		
	Leakage Current		mA		Measure current in water loop pipe		
Building Primary Electrical Ground to unit, must meet local diameter and penetration length requirements. Do not connect heat pump to steel pipe unless dissimilar materials are separated by using Di-electric unions. Galvanic corrosion of heat pump water pipe will occur.							

ppm = parts per million
ppb = parts per billion

20. WATER QUALITY REQUIREMENTS

1. The Water Quality Table provides water quality requirements for coaxial and brazed-plate heat exchangers.
2. The water must be evaluated by an independent testing facility comparing site samples against this table. When water properties are outside of these parameters, the water must either be treated by a professional water treatment specialist to bring the water quality within the boundaries of this specification, or an external secondary heat exchanger must be used to isolate the heat pump water system from the unsuitable water. Failure to do so will void the warranty of the heat pump system and will limit liability for damage caused by leaks or system failure.
3. Regular sampling, testing and treatment of the water is necessary to assure that the water quality remains within acceptable levels thereby allowing the heat pump to operate at optimum levels.

4. If closed-loop systems are turned off for extended periods, water samples must be tested prior to operating the system.
5. For optimal performance, it is recommended that the closed-loop piping systems are initially filled with de-ionized water.
6. Well water with chemistry outside of these boundaries, and salt water or brackish water requires an external secondary heat exchanger. Surface/Pond water should not be used.
7. If water temperature is expected to fall below 40°F (4.4°C), antifreeze is required. Refer to the heat pump IOM for the correct solution ratios to prevent freezing.

Strainer / Filter Strainer / Filter Sizing			
Mesh Size	Particle Size		
	Microns	MM	Inch
20	840	0.840	0.0340
30	533	0.533	0.0210
60	250	0.250	0.0100
100	149	0.149	0.0060
150	100	0.100	0.0040
200	74	0.074	0.0029

8. Hydrogen Sulfide has an odor of rotten eggs. If one detects this smell, a test for H2S must be performed. If H2S is detected above the limit indicated, remediation is necessary (Consult with your Water Testing/Treatment Professional) or a secondary heat exchanger is required using appropriate materials as recommended by the heat exchanger supplier.
9. Suspended solids and particulates must be filtered to prevent fouling and failure of heat exchangers. Strainers or particulate filters must be installed to provide a maximum particle size of 600 micron (0.60 mm, 0.023 inch) using a 20 to 30 mesh screen size. When a loop is installed in areas with fine material such as sand or clay, further filtration is required to a maximum of 100 micron. Refer to the Strainer / Filter Sizing Chart to capture the particle sizes encountered on the site.
10. The WSHP piping system or other plumbing pipes must not be used as the building ground. An electrical grounding system using a dedicated ground rod meeting NEC and local electrical codes must be installed.
11. Refer to the Antifreeze Percentages by Volume table for instructions on measuring resistance and leakage currents within water loops.

20.1 Measuring Earth Ground Resistance for Ground-Water Applications

Measure the earth ground bond using an Ohm meter between the building's ground rod and the steel well casing.

The resistance measured should be zero Ohms. The NEC allows a resistance to ground up to 20 Ohms. Any resistance above zero indicates a poor earth ground, which may be the result of a hot neutral line or that conductive water is present. Both of these may lead to electrolysis and corrosion of the heat pump piping. A check for both should be performed and resolved.

NOTE: If the well casing is plastic, a conductive path can be achieved by inserting a #6 AWG bare copper wire into the well water. Remove the temporary conductor when finished.

20.2 Water Quality Requirements

Measure the electrolysis voltage using a volt meter between the heat pump ground and a #14 AWG solid copper wire electrode inserted into the water using a Pete's style access port.

The heat pump must be operating and the water stream flowing. The voltage measured should be less than 300 mV (0.300 V). If the voltage is higher than 500 mV, electrolysis will occur and corrosion will result. If voltage is measured, the cause is a high-resistance earth ground or current on the neutral conductor.

Remedial measures should be performed. Measure the current flowing through the piping system by using an amp clamp probe on the water-in line.

The heat pump must be operating and the water stream flowing. There should be zero amps measured. If current is present, there is leakage current to the plumbing system and it must be rectified to prevent pipe corrosion.

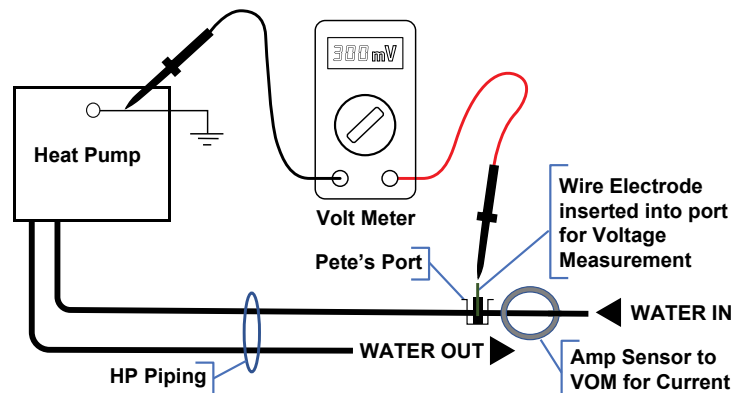

21 PIPING SYSTEM CLEANING AND FLUSHING

Cleaning and flushing the WSHP piping system is the single most important step to ensure proper start-up and continued efficient operation of the system.

Follow the instructions below to properly clean and flush the system:

1. Ensure that electrical power to the unit is disconnected.
2. Install the system with the supply hose connected directly to the return riser valve. Use a single length of flexible hose.
3. Open all air vents. Fill the system with water. DO NOT allow system to overflow. Bleed all air from the system. Pressurize and check the system for leaks and repair as appropriate.
4. Verify that all strainers are in place. A strainer with a #20 stainless steel wire mesh is recommended. Start the pumps, and systematically check each vent to ensure that all air is bled from the system.
5. Verify that make-up water is available. Adjust make-up water as required to replace the air which was bled from the system. Check and adjust the water/air level in the expansion tank.
6. Set the boiler to raise the loop temperature to approximately 85°F [29°C]. Open a drain at the lowest point in the system. Adjust the make-up water replacement rate to equal the rate of bleed.
7. Refill the system and add trisodium phosphate in a proportion of approximately one pound per 150 gallons (0.8 kg per 1000 l) of water (or other equivalent approved cleaning agent). Reset the boiler to raise the loop temperature to 100°F [38°C]. Circulate the solution for a minimum of 8 to 24 hours. At the end of this period, shut off the circulating pump and drain the solution. Repeat system cleaning if desired.
8. When the cleaning process is complete, remove the short-circuited hoses. Reconnect the hoses to the proper supply, and return the connections to each of the units. Refill the system and bleed off all air.
9. Test the system pH with litmus paper. The system water should be in the range of pH 6.0 - 8.5 (see the Water Quality Requirements Table). Add chemicals, as appropriate to maintain neutral pH levels.
10. When the system is successfully cleaned, flushed, refilled and bled, check the main system panels, safety cutouts and alarms. Set the controls to properly maintain loop temperatures.



DO NOT use “Stop Leak” or similar chemical agent in this system. Addition of chemicals of this type to the loop water will foul the heat exchanger and inhibit unit operation.



The manufacturer strongly recommends all piping connections, both internal and external to the unit, be pressure tested by an appropriate method prior to any finishing of the interior space or before access to all connections is limited. Test pressure may not exceed the maximum allowable pressure for the unit and all components within the water system. The manufacturer will not be responsible or liable for damages from water leaks due to inadequate or lack of a pressurized leak test, or damages caused by exceeding the maximum pressure rating during installation.

22 INSTALLATION

22.1 Piping

Unit loop and water connections utilize 3/4”, 1” swivel FPT connections with nylon O-washers. Fittings should be hand-tightened only. Over-tightening connections can cause leaks, or other equipment damage.

When connecting the unit to the building loop, a hose kit or other connection fitting with P/T ports should be utilized.

On units equipped with brazed-plate heat exchangers, a 20 Mesh strainer on the inlet loop connection is required to prevent damage due to debris.

22.2 HIGH VOLTAGE WIRING

All line voltage wiring should enter through the appropriate knockout, and be held with a strain relief connector. Refer to the unit data plate, or unit electrical data table, for unit electrical requirements. Copper conductors are the only approved line voltage wiring.

22.3 LOW VOLTAGE WIRING

All low voltage wiring should enter through the appropriate knockout, and be held with a strain relief connector.

22.4 WIRING CONNECTIONS

All high and low voltage wiring should be connected to the appropriate terminals as shown on the unit wiring diagram.

22.5 CONDENSATE DRAIN

When connecting the condensate drain, make sure there is adequate spacing around the cabinet before connecting piping. All condensate drains must be pitched away from the unit a minimum of 1/4" (6) per foot for proper drainage (see page 9).



Water connections must follow local plumbing and building codes.



Three phase components must have correct rotation verified at start up.

Verify by checking compressor and motor amp draw will be considerably lower than nameplate values. Reverse rotation results in a compressor overload trip and is associated with a loud buzzing noise.



The installation of water source heat pumps that include installation shall be in accordance of all authorities having jurisdiction and must conform to all applicable codes. It is the responsibility of the installing contractor to determine and comply with all applicable codes and regulations.

23 MOUNTING • MODEL 44PV-B VERTICAL PACKAGED WSHP UNITS

23.1 Location

Vertical cabinets are typically mounted on top of a vibration absorbing pad that is larger than the cabinet. The absorption pad minimizes vibration from the cabinet, and the unit should not come into direct contact with the building. To further reduce sound transmission flexible duct connection must be used on all ducted applications.

Units are required to have adequate clearance around the cabinet for maintenance accessibility such as:

- | | |
|---|---|
| 1. Filter Replacement | 5. Servicing Evaporator Coils |
| 2. Drain Pan Cleaning | 6. Access to Water Fittings and Valves. |
| 3. Control Box/Electrical Accessibility | 7. Disconnect Switch operation |
| 4. Fan and Motor Maintenance | 8. Unit Removal |

Please note that majority of vertical packaged WSHP are installed in mechanical rooms or closets and will require a louvered door for air to pass through the unit.

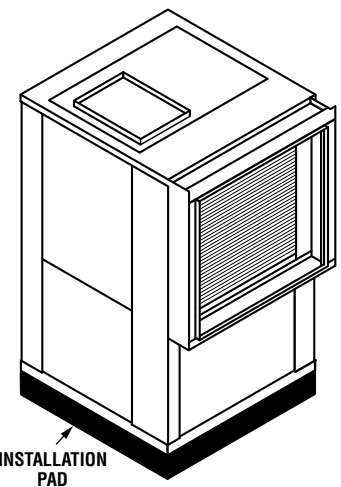

Never install units outdoors or areas indoors where humidity levels can cause cabinet condensation or are subject to freezing.



Follow all applicable codes requirements when hanging this unit. All hanging units must conform to local codes.

24 MOUNTING • MODEL 44PH-B HORIZONTAL PACKAGED WSHP UNITS

24.1 Location

Horizontal cabinets are typically suspended in a false ceiling or plenum with field provided threaded rods. Threaded rods are attached to four hangar brackets that are provided with the unit. Refer to the instructions and Fig. 2 and Fig. 3 when installing threaded rods.

Units are required to have adequate clearance around the cabinet for maintenance accessibility such as:

- | | |
|---|---|
| 1. Filter Replacement | 5. Servicing Evaporator Coils |
| 2. Drain Pan Cleaning | 6. Access to Water Fittings and Valves. |
| 3. Control Box/Electrical Accessibility | 7. Disconnect Switch operation |
| 4. Fan and Motor Maintenance | 8. Unit Removal |

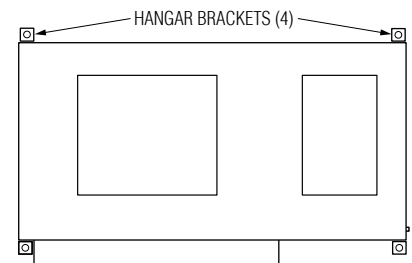

FIG. 2

24.2 Mounting

Horizontal units include hanging bracket kits for mounting the unit that include:

1. Hanging Brackets (Integral to the unit)
2. Rubber Isolators (4)

Mounting locations shown in Fig. 3 - Details A.



Units are required to be pitched to enhance condensate drainage. Its recommended to pitch the unit $\frac{1}{8}$ toward the drain connection. See Fig. 3

Fig. 4 shows the cross section of how to install hanging bracket kits.



Use all-thread with a diameter of at least $\frac{3}{8}$ " and washers with a diameter of at least 1".

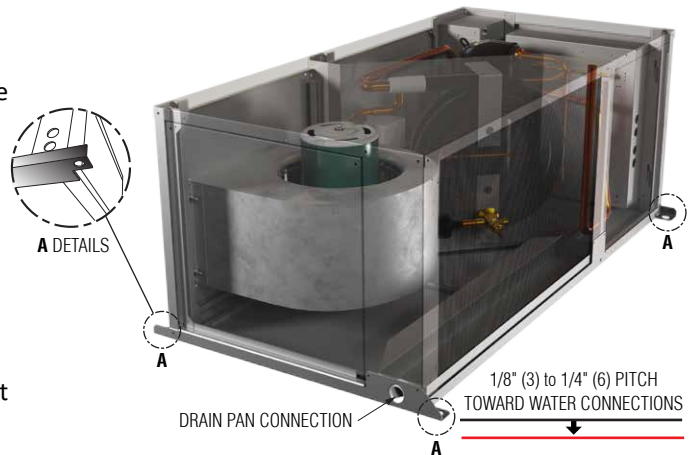

FIG. 3

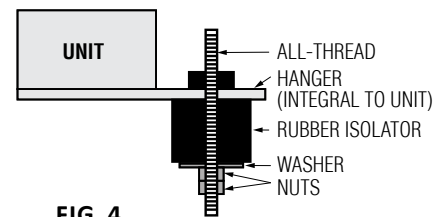
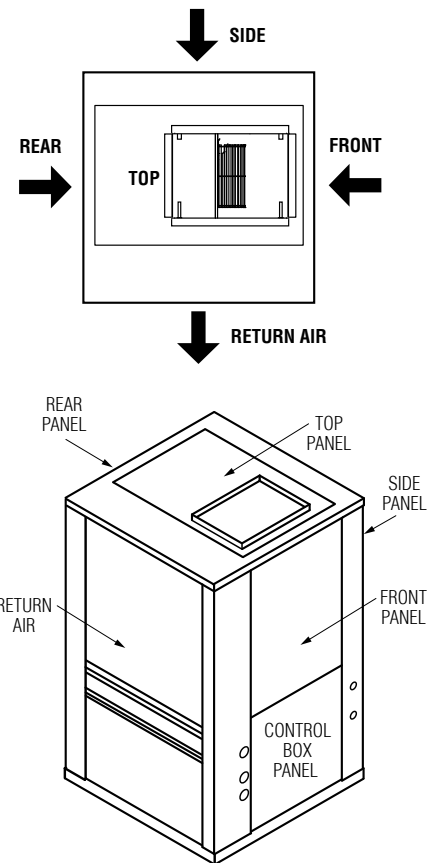

FIG. 4



25 AIR DISCHARGE • MODEL 44PV-B VERTICAL PACKAGED WSHP UNITS

25.1 Vertical Supply Air Discharge

Vertical Packaged WSHP can be converted to several variations:

Top, Front, Rear and Side (opposite to return)

Follow the steps below when converting discharge panels:

1. Switch off the disconnect switch or unit power.
2. Remove the screws from the side discharge or rear discharge. There are screws (4) per panel.
3. Remove the access panel
4. Unplug the motor harness through the access panel opening.
5. Remove the screws from the blower discharge panel, then remove the blower and motor assembly.
6. Swap panels to your desired orientation, while ensuring the blower does not come into contact with the evaporator coil or piping.
7. Reroute the motor harness to the motor before reinstalling panels. Electrical connections should not be in contact with other components or in tension.
8. Reinstall the blower discharge panel.

By hand spin the fan wheel. The wheel should spin freely without coming into contact with the blower housing.

25.2 Vertical Return Air Discharge

Vertical units are unable to convert return panels due to refrigeration piping. Vertical units can be rotated 180 degrees to meet return requirements.

26 AIR DISCHARGE CONVERSION • MODEL 44PH-B HORIZONTAL PACKAGED WSHP UNITS

Horizontal Packaged WSHP units have a variety of air discharge conversions. It is recommended to complete this step prior to hanging the unit, if the unit is suspended you must lower the unit before this conversion.

26.1 Horizontal Supply Air Discharge

Horizontal units can be converted from side to rear or rear to side discharge. Follow the steps below when converting discharge panels:

1. Switch off the disconnect switch or unit power.
2. Remove the screws from the side discharge or rear discharge. There are four screws per panel.

3. Remove the access panel.
4. Unplug the motor harness through the access panel opening.
5. Remove the screws from the blower discharge panel, then remove the blower and motor assembly.
6. Swap panels to your desired orientation, while ensuring the blower does not come into contact with the evaporator coil or piping.
7. Reroute the motor harness to the motor before reinstalling panels. Electrical connections should not be in contact with other components or in tension.
8. Reinstall the blower discharge panel.
9. By hand spin the fan wheel. The wheel should spin freely without coming into contact with the blower housing.
10. Reinstall the access panel.

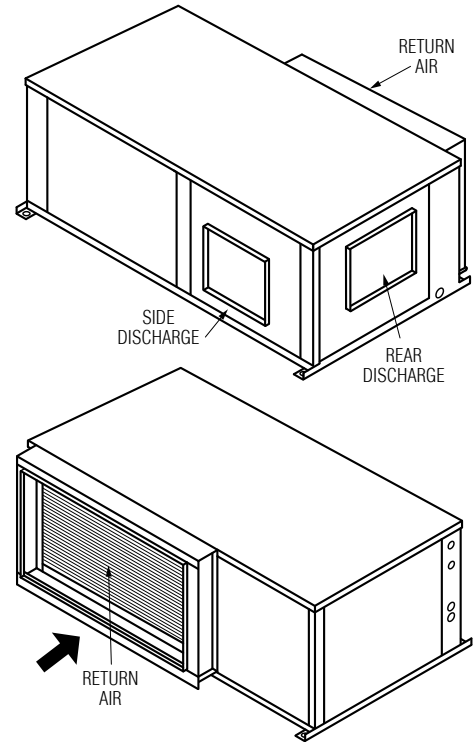

26.2 Horizontal Return Air Discharge

Horizontal units are unable to convert return panels due to refrigeration piping. Horizontal units are available in left or right orientations to account for this.

27 DUCT INSTALLATION

Uniform and adequate airflow is critical to the performance of the unit. Airflow through the cabinet must be at the specified airflow provided in the design guide.

All units contain return duct flanges and supply air duct connections. Flexible duct connector is recommended on metal ducting for both supply and return.

If the unit is installed in existing ductwork, the duct system must be checked to verify it has the capacity to handle the applications rated airflow. If the duct system is unable to handle the required airflow new duct work must be installed. Verify the existing duct work is free of leaks and repairs.



You must follow ASHRAE procedures for proper duct installation and sizing.

28 WATER PIPING INSTALLATION

MAKE SURE RISER VALVES ARE CLOSED BEFORE PRESSURING PIPING SYSTEM. ONCE ALL BUILDING PIPING IS LEAK FREE START THE AIR VENTING PROCEDURE.

1. Connect the hose (flexible piping) to the supply riser side or threaded fitting marked supply (in), perform the same on the return riser side to the package unit (HAND TIGHTEN ONLY).
2. Slightly loosen the return Flex hose at the return riser ball valve so air can be bled from the line into a drain.
3. Open the ball valve on the supply hose slowly, letting the water into the package unit to force the air out of the unit water components and return hose.

On units provided with electric shut-off valves, manually open the electric shut-off valve while venting the unit. When venting is completed, release manual override of electric shut-off valve.

4. When a steady stream of water is flowing out of the return hose, tighten the return hose onto the riser ball valve (HAND TIGHTEN ONLY).
5. Open both ball valves slowly while visually inspecting for leaks. If small leaks are present on the hose connection, the hose connection must only be tightened until leaks stop. Over tightening may pinch or cut the rubber gasket.
6. When water piping and final unit installation is complete, complete start up procedure.

29 CONDENSATE DRAIN

Units are required to have a pitched condensate drain line to direct condensate away from the unit. All connections must be in conformance off all plumbing/building codes.

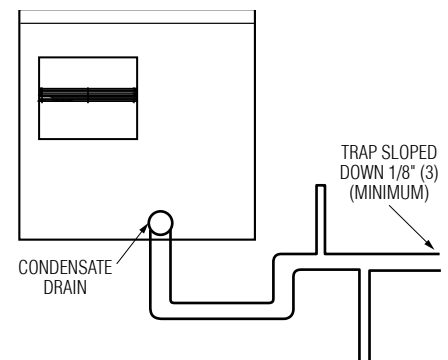

Drain line must be pitched opposite to the unit at a minimum of 1/8" (3) per foot. Within the drain line a trap is required, which helps free condensate flow. Distance of the trap is dependent on the amount of air pressure the drain pan is receiving during operation.

Units must be pitched to a minimum of 1/4" (6) on horizontal units to improve condensate drainage. See mounting horizontal cabinets above.



Over pitching units can result in condensate leaks within the cabinet.

30 UNIT START-UP

30.1 Pre-Start-up Checklist

- High voltage wiring and breakers are installed and properly sized.
- Low voltage control wiring is connected to the proper terminals.
- Any connected loop and load pumps, or water control valves are installed and wired properly. And have been cleaned prior to start-up.
- All applicable piping such as loop, load, hot water, and condensate drain are properly connected.
- Any installed shutoff valves have been opened, and all air and debris have been purged from all circuits.
- Ductwork is in-place and secure, and air filter is in-place (if applicable).
- Any internal shipping materials have been removed, and the blower wheel turns freely (if applicable).
- All unit access panels are in-place and secure. Leave controls access panel off during unit start-up and checkout.
- Any connected thermostat, building automation system, or controller is in the "Off" configuration.

30.2 Start-up Steps

7. Have the Unit Start-up form at hand to record all readings during start-up.
8. Turn on all electrical breakers connected to the unit.
9. Check high voltage to insure it is within the proper range according to the unit data plate.
10. Verify that the included display is active and displaying similar to below.
11. Select the mode to run the unit in, either heat or cooling.
12. Check for proper loop flow via the P/T (field provided) ports on the "In" and "Out" loop connections on all connected circuits.
13. During operation, check high voltage readings to ensure it is within the ranges specified in the Unit Electrical Data Table.
14. Check the temperature difference between the loop(s) "In" and "Out" loop connection P/T (field provided) ports. Allow 10 - 15 minutes of unit operation before checking.
15. Check the temperature difference between the return and supply air. Allow 10 - 15 minutes of unit operation before checking (if applicable).

Once all start-up steps have been completed, and the unit is operating within normal parameters, install any open access panels, and complete the unit start-up form.

30.3 System Loop Temperature and Conditions



Extremely Important: Clean water conditions and EWT conditions must be established and maintained for the unit to operate in the conditions specified by the original unit and system specification. Water cleanliness and temperature conditions must be maintained for the units to operate as intended. Normal maintenance is recommended to ensure these conditions.

The units flow rate should be established by autoflow controls installed, in the absence of flow controls, PT port temperature and pressure drop consistent with performance specification should be established at each unit on each riser to ensure the unit is performing at design specified conditions.



Installation and Operation Manual • Serenity Packaged Water Source Heat Pump Units – Model Series 44P

30.4 Start-up Form

Installation Date:		Start-Up Date:	
Customer Name:		Unit Tag Number:	
Customer Address:			
Model Number:		Serial Number:	
Technician Name:		Phone Number:	
Contractor Name:		Phone Number:	
Building Loop Type:		Unit Voltage:	
Controller Type:		Unit Breaker Size:	
		Unit Wire Size:	
Functional Check:	Heating Mode:		Cooling Mode:
Loop "In" Pressure: (PSI) or (kPa)		Flow Rate:	Flow Rate:
Loop "Out" Pressure: (PSI) or (kPa)			
Load "In" Pressure: (PSI) or (kPa)		Flow Rate:	Flow Rate:
Load "Out" Pressure: (PSI) or (kPa)			
HW "In" Pressure: (PSI) or (kPa)		Flow Rate:	Flow Rate:
HW "Out" Pressure: (PSI) or (kPa)			
Loop "In" Temperature: (°F) or (°C)		Differential:	Differential:
Loop "Out" Temperature: (°F) or (°C)			
Load "In" Temperature: (°F) or (°C)		Differential:	Differential:
Load "Out" Temperature: (°F) or (°C)			
HW "In" Temperature: (°F) or (°C)		Differential:	Differential:
HW "Out" Temperature: (°F) or (°C)			
Supply Air Temperature: (°F) or (°C)		Differential:	Differential:
Return Air Temperature: (°F) or (°C)			
Compressor Electrical:	Volts:	Amps:	Volts: Amps:
Blower Electrical:	Volts:	Amps:	Volts: Amps:
Pump Electrical:	Volts:	Amps:	Volts: Amps:

30.5 Auxiliary Electric Heat (if applicable)

Supply Air Temperature: (°F) or (°C)		Differential:
Return Air Temperature: (°F) or (°C)		
Auxiliary Heat Electrical	Volts:	Amps:

31 HEAT PUMP CHARGING

Once the air side and water side of the system have been balanced to ensure proper airflow and water flow per the project specification, the unit can be reviewed for proper operation. The unit factory charge is shown on the unit nameplate. If a charge adjustment is needed the following guidelines should be used. The charge should be adjusted to 10 -12°F subcooling at the unit liquid before the thermal expansion valve. The thermal expansion valve is factory set and should be measured to be between 5-10°F superheat at the compressor suction inlet. The thermal expansion valve is adjustable but should only be adjusted if out of the range specified above. If external devices are added to the unit such as gauges and other monitoring devices, the charge amount should be adjusted for the above sub cooling and superheat levels.

32 AIR FILTERS

Unit air filters should be checked every 30 days. Dirty or clogged air filters can degrade unit performance, and potentially increase energy usage. Always make sure the unit is not operating when checking the air filter.



CAUTION Do not operate units without air filters or prior to the completion of the building. Doing so will result in extensive unit clean up, fouled machinery, and will void warranty.

33 DRAIN PAN

The drain pan should be thoroughly inspected before summer operation with the removal of all debris to allow the proper flow of condensate.

Periodic inspection of the drain pan should be performed during the cooling operation to prevent any possibility of it becoming clogged with foreign matter. Use a bactericide or bacteriostatic drain pan conditioner that is pH neutral. Follow directions of product used to assure proper bacteria control. Never use a chlorine-based cleaning solution on WSHP units.

34 RETURN AIR FILTER

MERV Rating	Particle Size (in microns)			Particle Examples
	0.3 - 1.0	1.0 - 3.0	3.0 - 10.0	
4	–	–	> 20%	Pollen, Dust mites, Sanding dust
8	–	–	> 70%	Mold Spores, Cement dust
11	–	65 - 80%	> 85%	Auto emissions, Lead dust
13	> 75%	> 90%	> 90%	Tobacco smoke, Bacteria

THE UNIT RETURN AIR FILTER IS ONE OF THE MOST IMPORTANT PARTS OF THE WSHP SYSTEM. Proper system maintenance MUST include changing of the filter monthly to assure the unit air coil remains free of dust and other materials.

Upgrading the filter to a higher efficiency level (MERV Rating) up to a MERV 8 will provide more filtration of particles in the air and will result in a longer life of the heat pump and a cleaner environment. It is strongly recommended the use of high efficiency filters. The units are provided to the installing contractor with a "construction grade" filter.

Engineered Comfort offers three efficiency upgrades of filters that greatly exceed the MERV 4 construction grade filters. Each grade progressively increases the filtration performed.

Table above compares the minimum particle size each filter can remove from the air stream and the percentage of those particles that the filter will remove. The filters are: MERV 4, MERV 8, MERV 11 and MERV 13.

35 AIR COIL

Its recommended to clean the evaporator air coil prior to start-up. Cleaning the air coil will maximize the efficiency of the coil. Use a 10% dishwasher detergent solution around the coil, followed by a rinse.

36 FILTER SELECTION

The use of high efficiency filters increases the external static pressure on the fan and motor. The fan and motor must be sized properly to be capable of this extra static pressure. Upgrades to MERV 8 filters usually will not deteriorate unit performance.

Upgrades to MERV 11 or MERV 13 require analysis of the fan motor and any ductwork. Consult with the factory for proper sizing and selection.

37 TYPICAL PACKAGED WSHP OPERATING TEMPERATURES

A handheld temperature gun can be used for the supply and return air temperature measurements. Run the unit under normal conditions and compare readings with the information below:

Packaged WSHP	Value
Cap Of Distributor Tube Temperature At Coil	55 – 58 °F
Evaporator Saturated Suction Temperature	43 – 50 °F
Suction Line Temperature (With Superheat)	57 – 65 °F
Superheat At Compressor	7 – 15 °F
Sub Cooling	8 – 15 °F
Discharge Line Temperature	125 – 140 °F
Condensing Temperature Cooling	95 – 105 °F
Condensing Temperature Heating	100 – 110 °F
Air Temperature Into Evaporator Coil	Ambient
Air Temperature Off Of Evaporator Coil In Cooling	20 °F, Lower Than Ambient
Air Temperature Off Of Evaporator Coil In Heating	20 – 25 °F, Higher Than Ambient

Packaged WSHP	Value
Entering Water Temperature Cooling	60 – 120 °F
Leaving Water Temperature Cooling	8 – 10 °F Higher Than E.W.T
Entering Water Temperature Heating	40 – 90 °F
Leaving Water Temperature Heating	8 – 10 °F Lower Than E.W.T
Rated Water Flow Rate	3.0 gpm/ton
Minimum Rated Flow Rate	2.0 gpm/ton
Low Pressure Cut-Out/Cut-In	40 / 80 psig
Low Water Temperature Cut-Out	30 °F (Configurable to 10 °F)
Low Air Temperature Cut-out	30 °F
High Pressure Cut-Out/ Cut-In	600 / 500 psig

38 CONTROL OPERATION

All other systems should be operating properly before the controls function is tested.

Approved unit submittals, order acknowledgment, and other manuals should be consulted for detailed information regarding each individual unit and its controls. Care should be taken that the correct control procedures have been identified for the unit in question before any attempt is made to adjust the control sequence. For specific information on controls provided by other manufacturers contact the manufacturers local or national office. This applies whether the controls are factory or field mounted.

Nailor’s digital control for this unit type is configured to handle all the functions to operate a Water Source Heat Pump. The control has thermostat inputs (R, C, Y, W, O, G, AL1, AL2, A) and functional inputs and outputs to handle the following (See **Figure 1.**):

1. High and Low pressure switch inputs for the refrigerant pressures.
2. Two thermistor inputs for freeze protection. FP1, FP2
3. System over and under voltage protection.
4. Condensate fault monitoring, CO
5. Short cycle and random start timing for the compressor start up.
6. Reversing Valve output, RV
7. Alarm relay outputs, AL1, AL2, A
8. Electric Heat outputs, EH
9. Field selectable options

Field Selectable Option - Test mode: Test mode allows the service technician to check the operation of the control in a timely manner. By momentarily pushing the test button, the control enters a 20 minute test mode period in which all time delays are sped up 15 times. Upon entering test mode, the status LED will flash a code representing the last fault.

Test mode can be stopped by pushing the test button.

Retry Mode: If the control is attempting a retry of a fault, the status LED will slow flash (slow flash = one flash every 2 seconds) to indicate the control is in the process of retrying.

Field Configuration Options - Note: In the following field configuration options, jumper wires should be clipped ONLY when power is removed from the control.

LT1 = FP1

LT2 = FP2

Low temperature water coil limit setting: Jumper 3 (JW3- LT1 Low Temp) provides field selection of temperature limit setting for LT1 of 30°F or 10°F [-1°F or -12°C] (refrigerant temperature).

Installation and Operation Manual • Serenity Packaged Water Source Heat Pump Units – Model Series 44P

Not Clipped = 30°F [-1°C]. Clipped = 10°F [-12°C].

Low temperature air coil limit setting: Jumper 2 (JW2- LT2 Low Temp) provides field selection of temperature limit setting for LT2 of 30°F or 10°F [-1°F or -12°C] (refrigerant temperature). Note: This jumper should only be clipped under most circumstances, contact factory for application where under 30°F refrigerant temperature is necessary.

Not Clipped = 30°F [-1°C]. Clipped = 10°F [-12°C].

Alarm relay setting: Jumper 1 (JW1-AL2 Dry) provides field selection of the alarm relay terminal AL2 to be jumpered to 24VAC or to be a dry contact (no connection).

Not Clipped = AL2 connected to R. Clipped = AL2 dry contact (no connection).

DIP Switches - Note: In the following field configuration options, DIP switches should only be changed when power is removed from the CXM control.

DIP switch 1: Unit Performance Sentinel Disable - provides field selection to disable the UPS feature.

On = Enabled. Off = Disabled.

DIP switch 2: Stage 2 Selection - provides selection of whether compressor has an “on” delay. If set to stage 2, the compressor will have a 3 second delay before energizing. Also, if set for stage 2, the alarm relay will NOT cycle during test mode.

On = Stage 1. Off = Stage 2

DIP switch 3: Not Used.

DIP switch 4: DDC Output at EH2 - provides selection for DDC operation. If set to “DDC Output at EH2,” the EH2 terminal will continuously output the last fault code of the controller. If set to “EH2 normal,” EH2 will operate as standard electric heat output.

On = EH2 Normal. Off = DDC Output at EH2.

DIP switch 5: Factory Setting - Normal position is “On.” Do not change selection unless instructed to do so by the factory.

-Slow Flash = 1 flash every 2 seconds

-Fast Flash = 2 flashes every 1 second

-Flash code 2 = 2 quick flashes, 10 second pause, 2 quick flashes, 10 second pause, etc.

-On pulse 1/3 second; off pulse 1/3 second

Description of Operation	LED
Normal Mode	ON
Control is non-functional	OFF
Fault Retry	Slow Flash
Lockout	Fast Flash
Over/Under Voltage Shutdown	Slow Flash
Test Mode - No Fault in Memory	Flashing Code 1
Test Mode - HP Fault in Memory	Flashing Code 2
Test Mode - LP Fault in Memory	Flashing Code 3
Test Mode - LT1 Fault in Memory	Flashing Code 4
Test Mode - LT2 Fault in Memory	Flashing Code 5
Test Mode - CO Fault in Memory	Flashing Code 6
Test Mode - Over/Under Shutdown in Memory	Flashing Code 7

Table 1: LED and Alarm Relay Operations

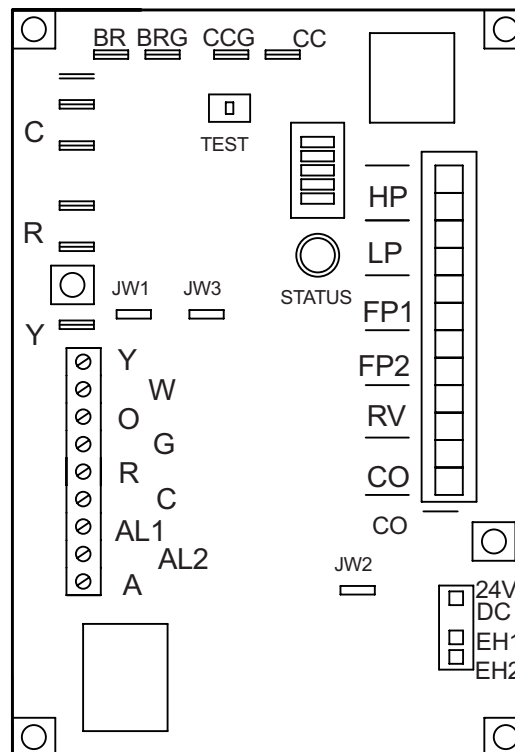

Figure 1. Water Source Heat Pump controller

39 TROUBLE DIAGNOSIS

Trouble diagnosis should only be attempted by qualified maintenance personnel. Before any troubleshooting is performed, verify that the thermostat has been programmed as required for proper operation on the installation in question. The thermostat must include a minimum 4-minute compressor anti-cycle timer.

40 FAN MOTOR FAILS TO START

1. Verify that all main power and circuit breakers are on and not tripped.
2. Turn system switch on and select HI or LO fan speed.
3. Remove grille and front panel and carefully remove cover to electrical control panel in cabinet.

4. Refer to wiring diagram on front panel, identify incoming power black and red or black and white wires and determine if unit is being supplied with correct voltage with Volt Ohm-meter (VOM).
5. If fan will not run on either LO or HI, verify 24 Volt transformer is operating correctly by checking voltage with VOM between black and white with green stripe wires in the thermostat plug. If 24 volts is not present, check low voltage output from transformer by checking with VOM at blue and yellow wires on transformer. If 24 volts is not present, replace transformer. If 24 volts is present, check continuity of the black or red wire connecting transformer to thermostat.
6. If transformer is OK, disconnect power at either the building breaker panel or unit disconnect switch. Remove thermostat cover and inspect for visible indications of system ground or short. Also check for proper wiring connections between thermostat and unit, to assure colors match per wiring diagram and that insulation is intact. Check "pin" terminals for good contact on thermostats equipped with polarized quick-connect plugs VERIFY PINS ARE FULLY PRESSED INTO THE CONNECTOR PLUG.
7. Determine if fan motor is being supplied correct voltage. If not, check the 24-volt relays that connect power to the fan motor. If relay normally open contacts do not close when thermostat is calling for fan and relay is energized, replace relay.
8. If fan has power and hums, turn off power and make sure fan rotates freely.
9. Remove fan and motor and inspect fan motor and fan motor capacitor wiring; verify wiring is correct. If capacitor wiring or shield is burned, replace wires. Check capacitor by removing wires from capacitor and measure capacitance with meter. Capacitance should measure within 6% of capacitor rating. If not, replace capacitor.
10. If fan motor is hot, it may be off on internal overload. Let cool and attempt to re-start. If fan runs, start and stop several times to determine if a starting problem. If fan continues to run, reinstall fan in cabinet and run for at least 10 minutes.
11. If fan will not run or cuts out on internal overload, replace motor.

41 HEAT PUMP UNIT FAILS TO START

Complete steps 1 - 3 if Fan Motor Fails to Start.

1. If Circuit Breakers are tripping when Heat Pump Unit is turned on, unplug heat pump unit. If circuit breakers continue to trip, check control box wiring and field connections and verify unit is wired in accordance with wiring diagram.
2. If unit caused circuit breakers to trip, identify red and black wires from heat pump unit plug and determine if red or black lead is shorted to ground with VOM. If wires are shorted, compressor replacement is Required by a qualified HVAC service technician.
3. Feel compressor in heat pump unit. If hot, allow to cool and attempt to restart. If the compressor starts, see the appropriate section below. If heat pump fails to restart, open heat pump unit control box and check for loose connections or burnt wiring. If none found, check the compressor thermal overload for continuity (if no continuity, overload is defective). If overload is OK, unplug unit and check compressor resistance with VOM between the red and black wires at the unit plug. Infinite ohms means that the internal overload is probably still open and compressor needs more time to cool. 2-5 ohms is the normal compressor winding resistance and indicates the compressor is O.K., but the capacitor may be bad or there may be a faulty connection at the control box plug or a starter problem in the control box.
4. If capacitor wiring or shield is burned, replace wires. Check capacitor by removing wires from capacitor and measure capacitance with meter. Capacitance should measure with 6% of capacitor rating. If not, replace capacitor.

42 HEAT PUMP UNIT STARTS BUT CUTS OFF COOLING ONLY UNITS

1. After unit cuts off, determine if there is ice formation on the evaporator coil or if the condenser coil is extremely hot.
2. If there is ice formation on the coil, check for poor seal between inner panel and coil. Check for proper airflow. Check for discharge grilles closed, blocked filters, etc. Is the room too cool (below 68°F [20°C]). If the supply water is 75°F (23°C) or less, there may be premature freezing of the evaporator coil. If airflow and water temperatures are O.K., unit may be low on charge. If so, service is required by a qualified HVAC service technician.
3. If condenser water coil is hot, check for proper water supply with flow meter, if available. Check water temperatures. With proper water flow, there should be a temperature rise of about 10°F (-12°C) from supply to return, and the supply water should be 95°F (35°C) or less. If no water flow, check electric water control valve for proper operation (if provided). The control valve is energized by the compressor contactor and is normally closed, power to open. If the control valve is operating properly, shut unit off and perform air venting procedure described in WATER PIPING INSTALLATION on page 8.
4. Inspect safety lock-out circuit. The unit is provided with a high-pressure switch that senses the refrigerant circuit condensing pressure and a low temperature switch that senses the refrigerant circuit suction temperature. These switches are normally

open, fail to close and are automatic resetting devices. The switches are wired in series with a lock-out relay that energizes when either switch energizes on a failure condition. The lock-out relay interrupts the control voltage to the compressor contactor and prevents the compressor from running. The lock-out circuit will reset when the call for compressor (Y circuit from the thermostat) or power to the unit is turned off and reset.

43 HEAT PUMP UNIT STARTS BUT CUTS OFF HEATING AND COOLING

1. If problem occurs in cooling, see checks under cooling only units.
2. If in heating and the unit cuts out, determine if there is ice formation on the evaporator coil or if the condenser air coil is extremely hot.
3. If there is ice formation on the evaporator coil or it is extremely cold, check for proper water flow and entering water temperatures between 65°F (18°C) and 75°F (23°C). With proper water flow, there should be a temperature decrease of about 8°F from supply to return. If no water flow, check electric water control valve for proper operation (if provided). The control valve is energized by compressor contactor and is normally closed, power to open. If the control valve is operating properly, shut unit off and perform air venting procedure described in WATER PIPING INSTALLATION on page 8. If water flow and temperature is O.K., Unit may be low on charge. If so, service is required by a qualified HVAC service technician.
4. If condenser air coil is extremely hot and compressor is hot, check for proper airflow. Select HI fan speed if fan is on LO speed and check for poor air seal between inner panel and coil, discharge grilles closed, blocked filters, etc. Is the room too hot (above 80°F).
5. Check the safety lock-out circuit as described for Cooling Only units.

44 HEAT PUMP UNIT OPERATING BUT NOT HEATING (REVERSE CYCLE ONLY)

1. Feel condenser air coil and evaporator water coil. If the water coil is not cool and the condenser coil not warm, system may not be properly charged or compressor is defective. If so, service is required by a qualified HVAC service technician.
2. If unit is cooling when heating is selected, verify that thermostat is set to correctly control the reversing valve. Refer to wiring diagram and locate blue (or orange) wire in control box and determine if it is supplying correct voltage to reversing valve solenoid coil. If correct voltage is supplied, shift unit rapidly from heating to cooling and listen for clicking sound in heat pump unit. If no voltage, check wiring harness for proper connections (loose wires, etc). If valve is clicking but not reversing, the valve has malfunctioned and requires replacement by a qualified HVAC service technician.

45 WIRING DIAGRAM

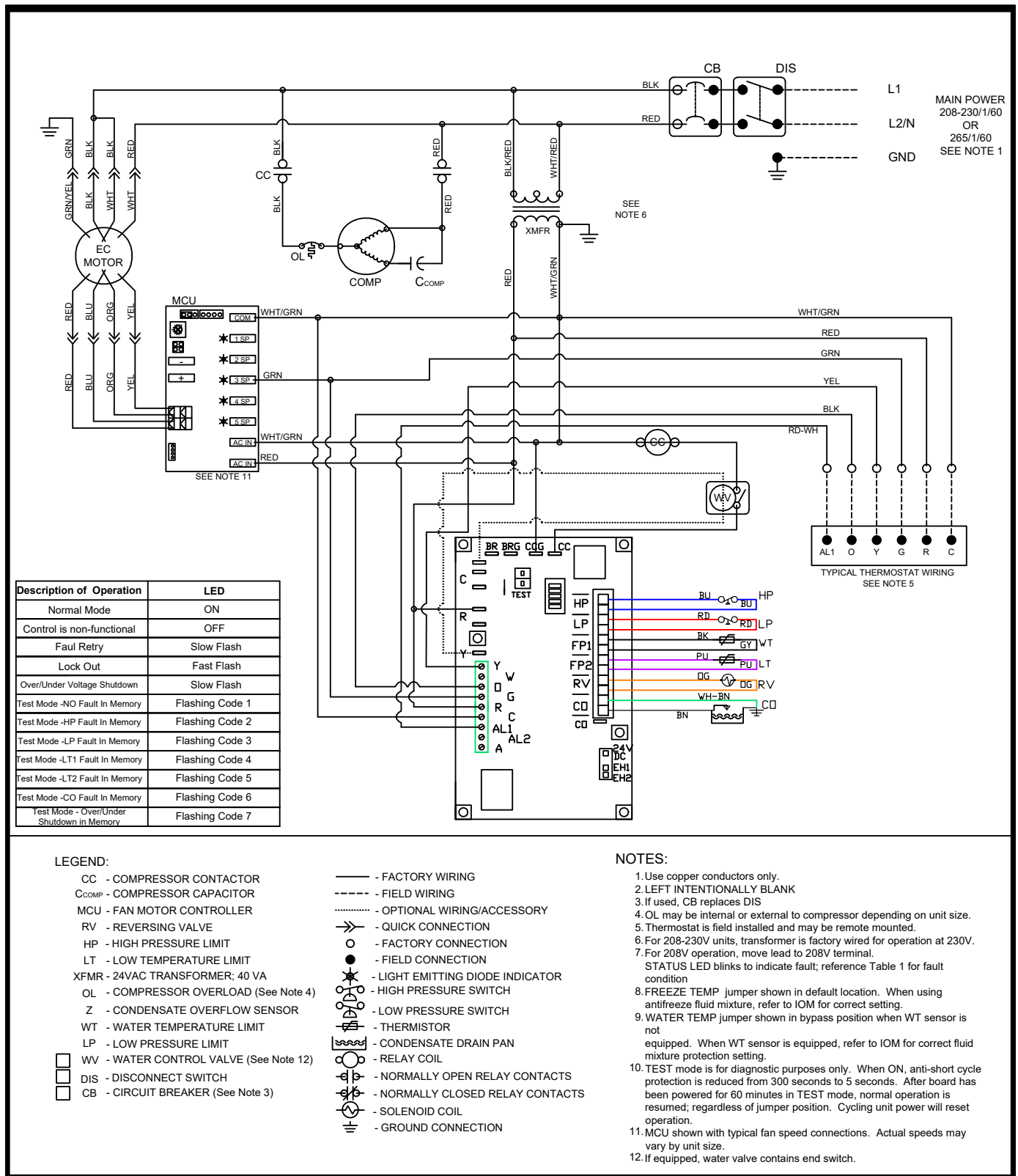

Figure 6. Serenity Packaged Water Source Heat Pump Units Wiring Diagram.

See controls section for more information.

46 WIRING DIAGRAM

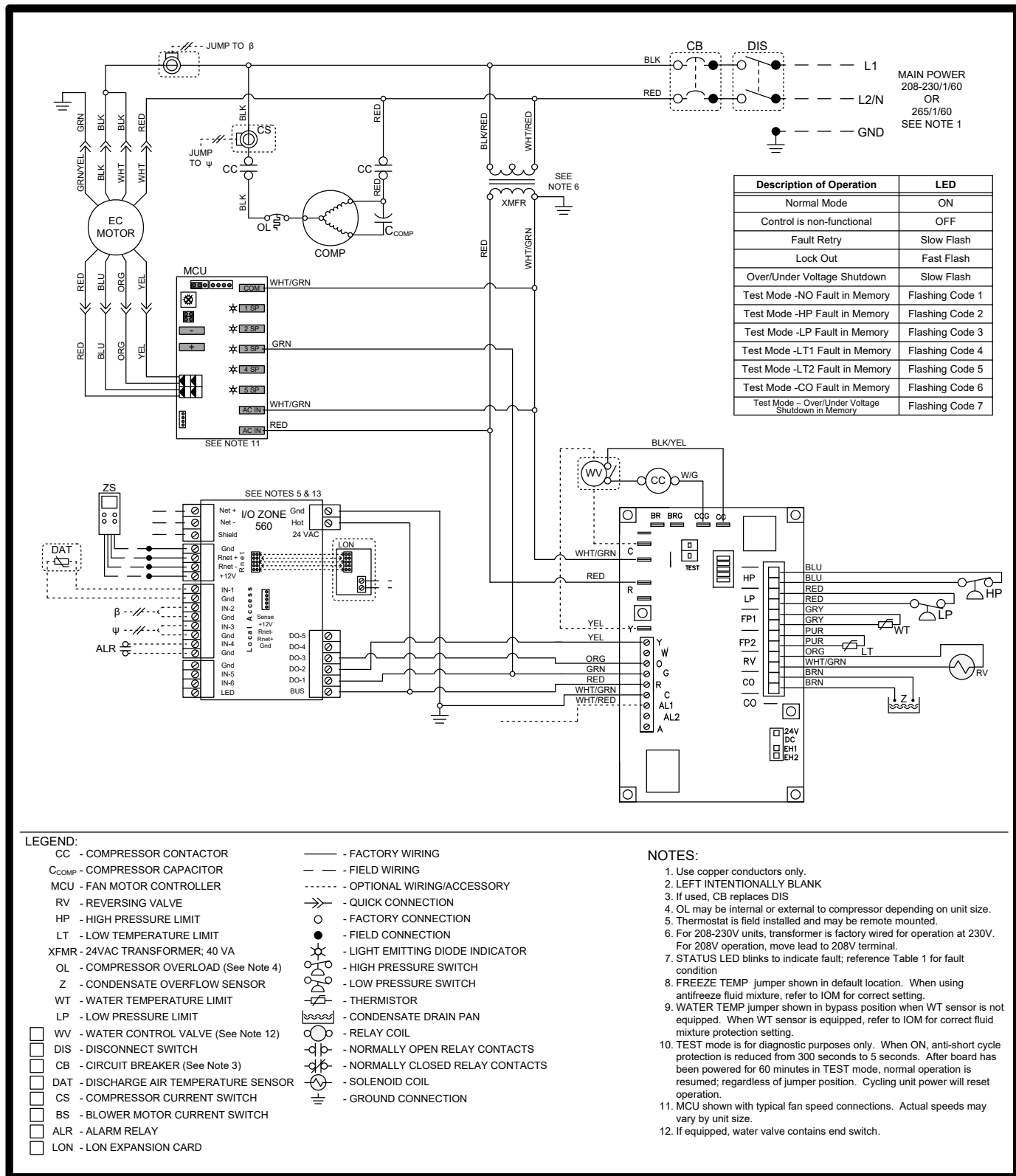

Figure 7. Serenity Packaged Water Source Heat Pump Units Wiring Diagram.
See controls section for more information.