

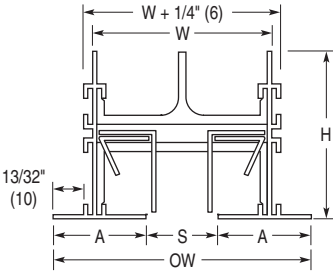

FLOWLINE™ LINEAR SLOT DIFFUSERS
ARCHITECTURAL • ALUMINUM
VERTICAL JET THROW PATTERN CONTROLLERS
MODEL SERIES: FLV TYPES AA & AAC

One Slot

- Type AA Exposed Flange Frame**
 • Drywall (ceiling, wall), T-bar



Two Slot

- Type AA Exposed Flange Frame**
 • Drywall (ceiling, wall), T-bar

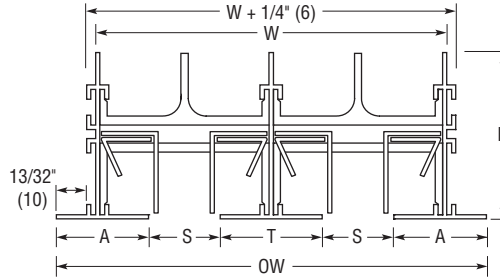

Dimensional Data - Imperial (Metric) Units

Model	S Slot Width	1 Slot		2 Slot		A Border Width	H Height	T 2 Slot
		W	OW	W	OW			
FLV10	1 (25)	2 1/2 (64)	3 9/16 (90)	4 15/16 (125)	6 (152)	1 9/32 (33)	2 3/8 (60)	1 7/16 (37)
FLV15	1 1/2 (38)	3 1/2 (89)	4 9/16 (116)	6 15/16 (176)	8 (203)	1 17/32 (39)	2 5/8 (67)	1 15/16 (49)
FLV20	2 (51)	4 1/2 (114)	5 9/16 (141)	8 15/16 (227)	10 (254)	1 25/32 (45)	2 7/8 (73)	2 7/16 (62)
FLV25	2 1/2 (64)	5 1/2 (140)	6 9/16 (167)	10 15/16 (278)	12 (305)	2 1/32 (52)	3 1/8 (79)	2 15/16 (75)
FLV30	3 (76)	6 1/2 (165)	7 9/16 (192)	12 15/16 (329)	14 (356)	2 9/32 (58)	3 3/8 (86)	3 7/16 (87)

- Type AAC Exposed Flange Frame**
 • Drywall (ceiling)

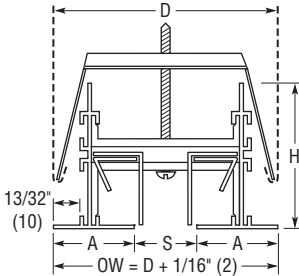

- Type AAC Exposed Flange Frame**
 • Drywall (ceiling)

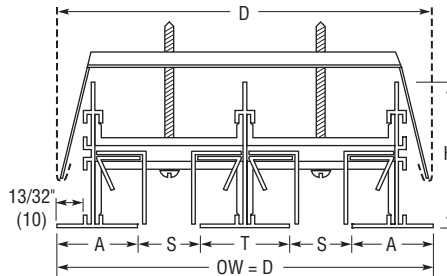

Dimensional Data - Imperial (Metric) Units

Model	S Slot Width	D Duct Width		Ceiling Opening Width		A Border Width	H Height	T 2 Slot
		1 Slot	2 Slot	1 Slot	2 Slot			
FLV10	1 (25)	3 1/2 (89)	6 (152)	3 (76)	5 1/2 (140)	1 9/32 (33)	2 3/8 (60)	1 7/16 (37)
FLV15	1 1/2 (38)	4 1/2 (114)	8 (203)	4 (102)	7 1/2 (191)	1 17/32 (39)	2 5/8 (67)	1 15/16 (49)
FLV20	2 (51)	5 1/2 (140)	10 (254)	5 (127)	9 1/2 (241)	1 25/32 (45)	2 7/8 (73)	2 7/16 (62)
FLV25	2 1/2 (64)	6 1/2 (165)	12 (305)	6 (152)	11 1/2 (292)	2 1/32 (52)	3 1/8 (79)	2 15/16 (75)
FLV30	3 (76)	7 1/2 (191)	14 (356)	7 (178)	13 1/2 (343)	2 9/32 (58)	3 3/8 (86)	3 7/16 (87)

Notes:

- Material: Heavy duty extruded aluminum frame and spacers. Corrosion resistant steel pattern controllers.
- Maximum section length is 72" (1823) by default. 96" (2438) and 120" (3048) are available as options. Lengths longer than the maximum section length are furnished in multiple sections with alignment strips, the number and size determined by the factory.
- Adjustable pattern controllers are on 24" (610) centers.
- AW Appliance White finish with black pattern controllers and interior surfaces is standard on frame/borders AA and AAC. Optional finishes are available.
- Frame/Border Type AA is supplied with integral hanger brackets on 24" (610) centers. Frame/Border Type AAC is supplied with concealed mounting brackets and levelling screws on 24" (610) centers. See separate submittal for optional mounting hardware and accessories.

Option:

- SP Special Finish _____.

Overall Length & End Cap Position

	E	L
<input type="checkbox"/> MM	D - 1/4 (6)	D + 9/16 (14)
<input type="checkbox"/> MO	D - 1/8 (3)	D + 9/32 (7)
<input type="checkbox"/> MC	D - 1/16 (2)	D + 11/32 (9)
<input type="checkbox"/> OO	D	D
<input type="checkbox"/> OC	D - 1/16 (2)	D - 1/16 (2)
<input type="checkbox"/> CC	D - 1/8 (3)	D - 1/8 (3)
<input type="checkbox"/> FF	D - 1/4 (6)	D + 1 5/8 (41)
<input type="checkbox"/> FO	D - 1/8 (3)	D + 13/16 (21)
<input type="checkbox"/> FC	D - 1/16 (2)	D + 7/8 (22)

End Condition

- M Mitered End Border**

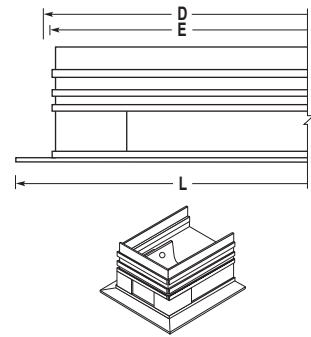

- F Flanged End Cap**
 Type AA Border Only

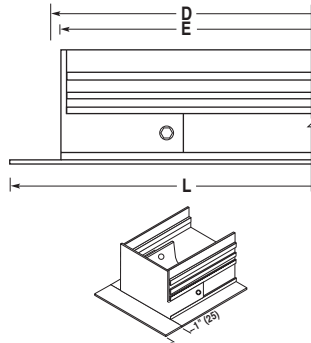

- O Open End**

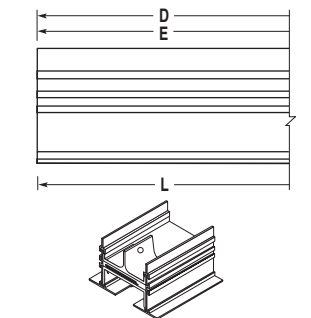

- C Flat End Cap**

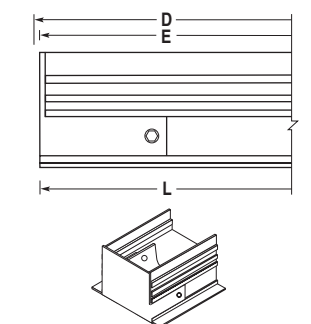

Dimensions are in inches (mm).

SCHEDULE TYPE

PROJECT

ENGINEER

CONTRACTOR

DATE

B SERIES

SUPERSEDES

DRAWING NO.

3 - 3 - 22

FL

4 - 12 - 16R

FLV-1